

# OVERSEAS ROAD NOTE

# 2

2nd Edition

## Maintenance techniques for District Engineers



Overseas Unit  
Transport and Road Research Laboratory · Crowthorne Berkshire United Kingdom

---

**Transport and Road Research Laboratory Overseas Unit**

Department of Transport  
Overseas Development Administration

---

## **Overseas Road Note 2**

# **Maintenance techniques for District Engineers (2nd Edition)**

---

Overseas Unit  
Transport and Road Research Laboratory  
Crowthorne Berkshire United Kingdom  
1985

## **ACKNOWLEDGEMENTS**

This Note was drafted by Mr L S Hitch, Mr T E Jones and Dr R Robinson of the TRRL Overseas Unit. It is based on an original text produced by Scott Wilson Kirkpatrick and Partners, consulting engineers.

First published 1981  
Second edition 1985  
Reprinted with minor revisions 1987

---

## **OVERSEAS ROAD NOTES**

---

Overseas Road Notes are prepared principally for road and road transport authorities in countries receiving technical assistance from the British Government. A limited number of copies is available to other organisations and to individuals with an interest in roads overseas, and may be obtained from:

Transport and Road Research Laboratory  
Crowthorne, Berkshire RG11 6AU  
United Kingdom

© Crown Copyright 1985  
Limited extracts from the text may be produced provided the source is acknowledged. For more extensive reproduction, please write to  
Head of Overseas Unit,  
Transport and Road Research Laboratory

## CONTENTS

	Page
1. Introduction	1
1.1 Scope of this Note	1
1.2 The Engineer's responsibilities	1
2. Methods of undertaking maintenance	2
2.1 Labour and equipment	2
2.2 Direct-labour and contract	3
3. Safety measures and traffic control	5
3.1 Principles	5
3.2 Edge working	5
3.3 Lane closure	5
3.4 Centre line working	7
3.5 Diversions	7
3.6 Development of safety measures	9
4. Maintenance of road furniture	9
4.1 Traffic signs	9
4.2 Rails and posts	9
4.3 White lines and reflective studs	10
4.4 Maintenance gangs	10
5. Maintenance of drainage, shoulders and slopes	11
5.1 The drainage system	11
5.2 Side drains	11
5.3 Fords and drifts	14
5.4 Culverts	14
5.5 Bridges	15
5.6 Shoulders	15
5.7 Slopes	16
5.8 Maintenance gang	16
6. Maintenance of unpaved roads	17
6.1 Types of maintenance	17
6.2 Grading	17
6.2.1 Types of grading	17
6.2.2 Crossfall	18
6.2.3 Steep hills	18
6.2.4 Grader operation	18
6.2.5 Grading gang	20
6.3 Dragging and brushing	21
6.3.1 Design of drag	21
6.3.2 Brushing	21
6.3.3 Method of operation	21
6.3.4 Dragging gang	24
6.4 Regravelling	24
6.4.1 The task	24
6.4.2 Quality of gravel	24
6.4.3 Organisation and equipment	24
6.4.4 Spreading gravel	25
6.4.5 Compaction	25
6.4.6 Continuous working	26
6.5 Filling and patching	26
6.6 Dust prevention	26
6.6.1 The dust problem	26
6.6.2 Remedial treatment	26

	Page
7. Maintenance of paved roads	27
7.1 Types of maintenance	27
7.2 Local sealing	27
7.3 Crack sealing	27
7.4 Patching	27
7.4.1 Procedure	27
7.4.2 Materials	28
7.4.3 Patching gang	28
7.5 Mechanised surface dressing	28
7.5.1 General principles	28
7.5.2 Design of surface dressing	29
7.5.2.1 Type of existing road surface	29
7.5.2.2 Traffic categories	29
7.5.2.3 Chippings	29
7.5.2.4 Binder	29
7.5.3 Equipment	30
7.5.4 Application	33
7.5.4.1 Preparation of the surface	33
7.5.4.2 Application of binder	33
7.5.4.3 Spraying temperatures	33
7.5.4.4 Jointing strips	34
7.5.4.5 Application of chippings	34
7.5.4.6 Rolling	34
7.5.4.7 Aftercare and opening to traffic	34
7.5.5 Control	34
7.6 Manual surface dressing	35
7.6.1 Applicability	35
7.6.2 Chippings	35
7.6.3 Binder	35
7.6.4 Application of binder	35
7.6.5 Application of chippings	36
7.6.6 Rolling	36
7.6.7 Gang size	36
7.7 Slurry sealing	36
8. References	37
Appendix A – Additional notes on surface dressing	37
A.1 Chippings	37
A.1.1 Size	37
A. 1.2 Average least dimension	37
A.1.3 Flakiness	39
A. 1.4 Adhesion and pre-treatment	40
A.1 .5 Stockpiling	41
A.2 Binder	41
A.2.1 Grade	41
A.2.2 Viscosity	41
A.2.3 Measuring the rate of spread of the binder	42
A.2.3.1 Average rate	42
A.2.3.2 Longitudinal variation	42
A.3 References	42

# 1. INTRODUCTION

## 1.1 SCOPE OF THIS NOTE

This Note describes the principal techniques that will be used to maintain roads within a District in a developing country. Particular attention is paid to the planning and design aspects of the work, as it is in this area that the Engineer will make the largest contribution. Practical execution is not described in detail.

The Note first discusses the merits of using labour or equipment-based operations and examines the scope for using local contractors for maintenance work. The importance of safety during maintenance work is then discussed and each of the various maintenance techniques is described in turn.

## 1.2 THE ENGINEER'S RESPONSIBILITIES

One of the key persons in any maintenance organisation is the professional engineer who is responsible for running the organisation at District or operational level. Although the District or Maintenance Engineer will usually be constrained to work within whatever management system is operated by his Department, there is invariably scope for improving the cost-effectiveness of the use of the resources available for road maintenance.

By adopting the same professional approach towards road maintenance as to any other engineering activity, he can inspire his staff to improve their own performance. The Maintenance Engineer should therefore show a personal commitment to maintenance work by regularly inspecting the roads under his control and making his staff aware of his interest. By getting out of the office and into the field as much as possible, the Engineer will be able to get to know his road network thoroughly and will readily identify trouble spots and other areas of difficulty. He will be able to assess priorities and will gain first-hand knowledge of what maintenance has actually been carried out, instead of having to rely on reports from others. He will also see the quality of the maintenance work carried out and will be able to use his professional skill and expertise to solve problems on-the-spot as they arise. Seeing him actually on site will give a boost to staff morale and this will result in an improvement in both the quality and quantity of work done. If there is one single factor which influences the standard of road maintenance more than all others, it is the attitude of the Engineer responsible.

The Engineer will find it difficult to follow this advice if he is overburdened with routine administrative work and it is essential that he delegates such activities to clerical and administrative staff as much as possible.

The Engineer will require adequate trained staff to carry out his instructions and he will need to arrange for supervisors, foremen and specialist artisans to attend suitable training courses. Accordingly the Maintenance Engineer must arrange for on-the-job training for labourers and other junior staff.

The supply and maintenance of equipment and vehicles is usually organised as a separate Departmental function and will be beyond the control of the Maintenance Engineer. Lack of suitable vehicles is always a major factor in maintenance organisations that are inefficient. The Maintenance Engineer must be aware of the importance of proper maintenance of equipment and vehicles and should actively concern himself with the organisation of this, as far as Departmental procedures allow.

The work of the District or Maintenance Engineer falls into three categories:-

- (i) Assessment of requirements: establishing what needs to be done in physical terms;
- (ii) Allocation of resources: estimating the men, materials and equipment required for different tasks, determining priorities and allocating resources to ensure the most cost-effective results;
- (iii) Monitoring: checking that the work done produces the desired results.

The management aspects of this work are described in more detail in a separate Note (TRRL Overseas Unit, 1981).

## 2. METHODS OF UNDER-TAKING MAINTENANCE

### 2.1 LABOUR AND EQUIPMENT

Most maintenance operations offer considerable scope for the application of labour-based methods and some are only practicable by such methods. No recommendation is made here for either equipment-intensive or labour-intensive methods, but Table 1 indicates the potential for equipment and labour-based methods in different maintenance operations.

In choosing between equipment-based and labour-based methods, consideration should be given to the standard of work achieved by each method as well as to costs and to the way in which the work is organised. It is not always necessary for labour-based operations to have the same standards of finish that can be

obtained by equipment. For example, on low-volume roads maintained by labour-based methods, there is unlikely to be any economic justification for insisting on the close tolerances of level and smoothness that can be achieved by the use of equipment.

Equipment and labour cannot be substituted directly for each other as, in addition to the question of standards already mentioned, it will usually be necessary to make changes in work organisation. The following points should be borne in mind when considering the use of labour-intensive maintenance methods: -

- (i) It is necessary to check carefully that labour will be available in the actual place where it is wanted, and at the time it is wanted.
- (ii) Adequate organisation and management are critical considerations for large scale labour intensive works.

**TABLE 1  
POTENTIAL FOR EQUIPMENT AND LABOUR**

ACTIVITY	POTENTIAL FOR	
	EQUIPMENT	LABOUR
Ditch cleaning and cutting	Good (*)	Good (*)
Cleaning and minor repair to culverts and bridges	Poor	Good
Building scour controls	Poor	Good
Repair of structures	Poor	Good
Grading unpaved surfaces	Good (Skilled) (ΨΨ)	Impracticable
Dragging and brushing of unpaved surfaces	Good	Poor
Patching sanding or local sealing of bituminous surfaces	Poor	Good
Filling on unpaved surfaces and slopes	Poor	Good
Grass cutting	Good (**)	Good
Manufacturing signs	Fair (Ψ)	Good (Ψ) (Skilled) (ΨΨ)
Repairing and replacing traffic signs	Poor	Good
Road line markings	Good	Fair
Stockpiling gravel	Good	Fair
Regravelling gravel surfaces	Good	Fair
Stockpiling chippings	Good	Poor
Surface dressing	Good (Skilled) (ΨΨ)	Fair (Skilled) (ΨΨ)

NOTES:

- (\*) The potential in these activities is dependent upon suitable design of the ditch cross-section. 'V'-shaped ditches are suitable for maintenance by grader whereas flat bottomed ditches are suitable for maintenance by hand or by mechanical shovel.
- (\*\*) The potential in this activity is dependent on the width of the shoulder and presence of obstructions such as road furniture and culvert headwalls.
- (Ψ) Some methods of manufacture may require the use of specialised plant (eg. vacuum application of reflective sheeting to sign plates).
- (ΨΨ) The expression 'skilled' implies that specific training of operatives is essential.

- (iii) The health and nutrition of the labour force are very important and improvements can increase productivity.
- (iv) Standardised tools of good quality are vital in order to achieve high levels of output.
- (v) It is normally inefficient to have labour and machinery working alongside each other on the same task.
- (vi) Arrangements may need to be made to transport labour to and from the work sites. For large labour forces, this can be a substantial task.

In addition, the supply or maintenance of equipment and vehicles can be undertaken by specialist contractors.

The Maintenance Engineer should satisfy himself that any contractor asked to tender is capable of completing the work satisfactorily, that he has the necessary equipment and staff, and that he has sufficient knowledge of estimating (or of current market rates) to be able to submit realistic prices.

## **2.2 DIRECT-LABOUR AND CONTRACT**

Road maintenance organisations usually carry out much of their work by direct-labour. However, some maintenance activities can be done by small local contractors and, where Departmental policy permits, the Maintenance Engineer should consider whether the use of such contractors is advantageous.

The use of contractors can reduce the burden on scarce government staff and also bring lower costs as a result of competitive pressures on efficiency which are unlikely to be obtained within a government department. However, contract work does require the preparation of detailed contract documents and a high degree of supervision, and the staff requirements and extra work involved for this should not be underestimated. There is also a danger that contractors bidding for maintenance work on a regular basis might introduce 'price fixing' to increase their profitability, and this will result in an increased cost to the maintenance department.

The following activities should present no serious problems in the control of quality or quantity if carried out by contract on the basis of competitive tender:-

### **Supply of Materials**

Natural gravel  
 Screened gravel  
 Rock aggregate (for subsequent crushing by Departmental crusher)  
 Crushed rock aggregate (for surface dressing and concrete)  
 Washed sand (for concrete)  
 Precast concrete blocks  
 Precast concrete culvert rings

### **Maintenance Operations**

Excavation of side drains and turnouts  
 Construction of culverts  
 Regravelling  
 Surface dressing  
 Grass-cutting and bush-clearing





Men working

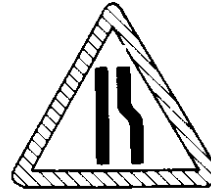

Road narrows on right ahead  
(Symbol may be reversed for 'road narrows on left ahead')

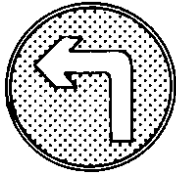

Turn left  
(the direction of the arrow may be reversed for 'turn right')

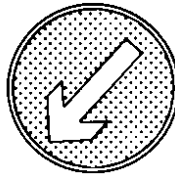

Keep left  
(The arrow may be pointed downward to the right for 'keep right')

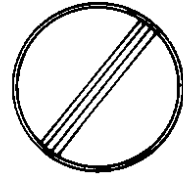

Road clear

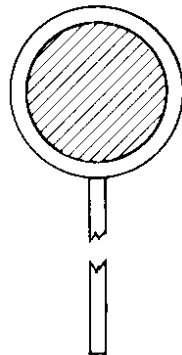
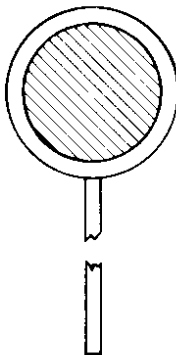

Reversible stop/go

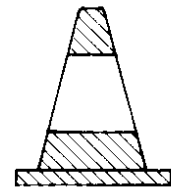

Traffic cone

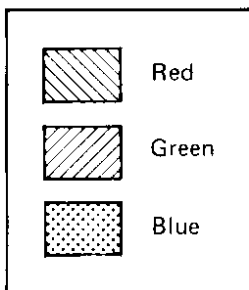
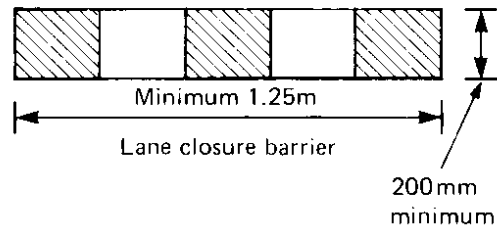

Notes:

- 1 All signs should be reflectorised
- 2 Minimum height of circular and triangular signs should be 1 metre (1.25 metres is preferred)

Fig.1 Standard signs

### 3. SAFETY MEASURES AND TRAFFIC CONTROL

#### 3.1 PRINCIPLES

When work is being carried out on or close to the carriageway, it is the Maintenance Engineer's responsibility to see that adequate measures are taken to warn and protect road users and maintenance workers. He should instruct all supervisors and foremen in safety measures, including traffic control, and the use of temporary road signs.

In selecting and positioning temporary road signs, the following principles should be applied:-

- (i) only standard signs should be used,
- (ii) the signs must be clean and in good condition,
- (iii) the standard signs should be displayed in a standard layout,
- (iv) the layout used must give drivers time to understand and respond to the information which the signs convey.

Recommended standard signs are shown in Fig. 1.

It may not be possible for the Engineer to purchase or obtain the necessary signs from Departmental stores, but the manufacture of adequate signs should be within the capabilities of a central signs workshop. Each road maintenance gang should be provided with signs appropriate to the work it is carrying out and all foremen and supervisors should be trained in their use and layout. All temporary signs must be removed as soon as the work they relate to is complete. If they are not the value of the signing will be reduced.

From the point of view of safety and traffic control, road maintenance work may be divided into four categories:

- (i) work which does not affect the carriageway, such as cleaning out side drains and cutting grass on verges (Section 3.2);
- (ii) work requiring partial closure of the carriageway, such as repair work to surface or base which is restricted to one lane while traffic continues to use the other lane (Section 3.3);
- (iii) work on the centre line, such as white line painting (Section 3.4);
- (iv) work requiring total closure of the road, with construction of a temporary diversion, such as the reconstruction of a damaged culvert (Section 3.5).

Whenever possible during maintenance work, yellow

or orange safety vests should be worn by the supervisor and all of the workforce. All vehicles and equipment should be painted yellow or orange and should carry red and white striped marker boards front and rear. All vehicles and equipment should work with headlights switched on and, where possible, should carry yellow flashing warning lights. If warning lights are not available, vehicles and equipment should carry a yellow or orange flag.

#### 3.2 EDGEWORKING

Where road works are being carried out which do not affect the carriageway, or where works such as grading or dragging are being carried out, the sign layout shown in Fig. 2 is recommended.

Warning signs should be placed before work starts and must be placed in the following order:

1. 'Men working' signs should be placed at the approaches to the work area.
2. 'Road clear' signs should be placed at the ends of the work area.

When the work has been completed, signs should be removed in reverse order. Signs must not be left on the road or at the roadside overnight. They should be removed and returned to the depot.

#### 3.3 LANE CLOSURE

For repairs to the carriageway such as patching which requires closure of one lane, the sign layout shown in Fig. 3 is recommended.

Before work starts, warning signs, barriers and cones must be placed around the work area. Work will be carried out on one side of the road at a time allowing traffic to pass on the other. Signs must be placed in the following order:

1. 'Men working' signs should be placed 200 metres in front of the work area.
2. 'Road narrows' signs should be placed 100 metres in front of the work area.
3. 'Keep left/right' arrows should be placed at the start of the work area.
4. Barriers should be placed at each end of the work area.
5. 'Keep left/right' arrows should be placed next to the barriers.
6. Cones should be placed in a taper at the approaches to the work area and at a spacing of 10 metres along the middle of the road next to the work area.
7. 'Road clear' signs should be placed 200 metres beyond the work area.

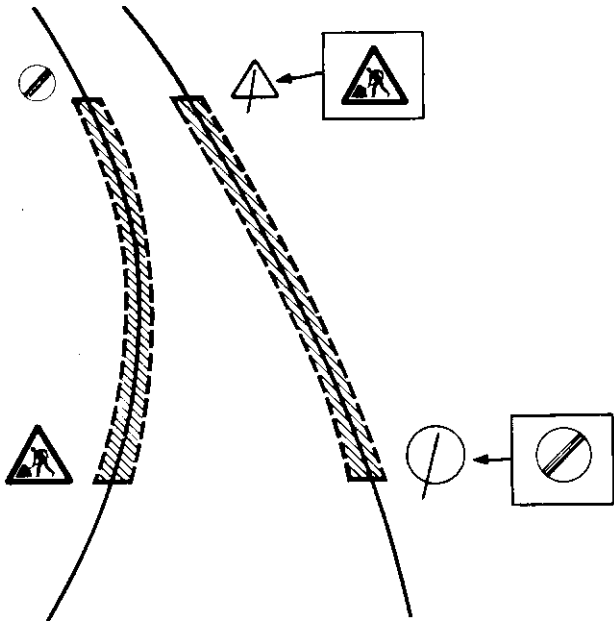

**Fig.2 Sign layout for edge working (drawn for driving on the left)**

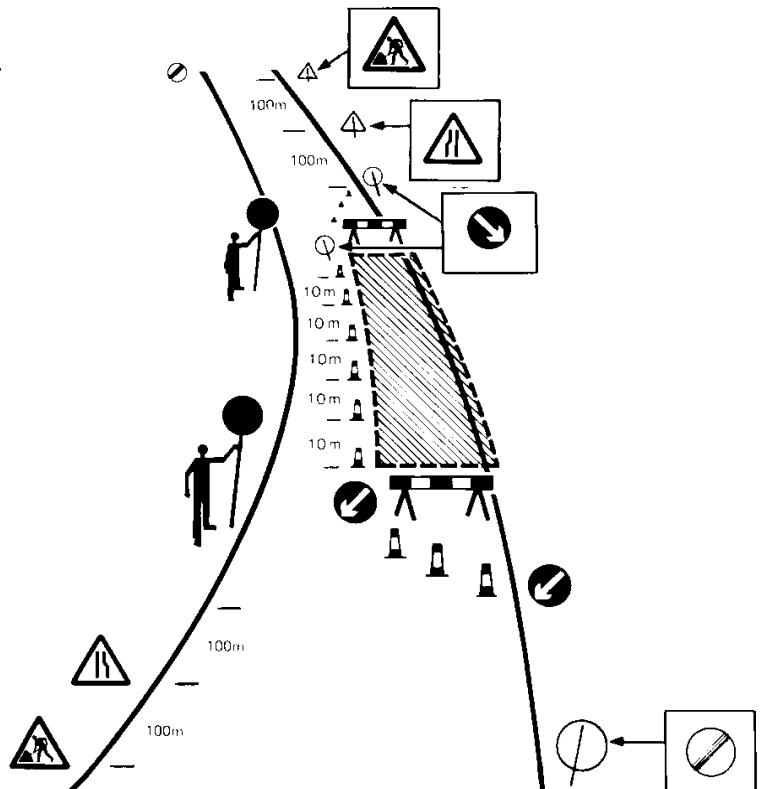

**Fig.3 Sign layout for lane closure (drawn for driving on left)**

Traffic controllers should stand opposite the barriers on the other side of the road holding reversible 'stop/go' signs. One controller should be appointed by the supervisor as the leader. He should decide when to change the direction of the signs and the other controller should follow his lead. In this way, the controllers work closely together to ensure that only traffic from one direction is allowed to pass at a time. When the work area is short, only one traffic controller may be needed. The Maintenance Engineer should train these men in the use of the signs and only the trained men should be allowed to operate them. Police assistance in training may be helpful.

On low traffic roads, the Maintenance Engineer may approve the use of a simpler system of traffic control.

Patching work should not be left unfinished over-night but, if this sign layout is being used for repairs to a culvert or a washout, then at night the approaches must be adequately lit. Kerosene lanterns may be adequate on lightly-trafficked roads or where speeds are low, but high-intensity lamps should, if possible, be used on heavily trafficked roads. A watchman should always be in attendance to ensure that the lamps are working and are not interfered with or stolen. Lamps should show a yellow light. Flashing lamps are best as they consume less power and are more easily seen.

When the work has been completed, signs should be removed in reverse order.

### 3.4 CENTRE LINE WORKING

When painting centre line markings on the road, considerable care must be taken and it is most important to pay a great deal of attention to safety measures. The sign layout shown in Fig. 4 is recommended.

Before work starts, warning signs, barriers and cones must be placed around the work area. They must be placed in the following order:

1. 'Men working' signs should be placed 200 metres in front of the work area at the side of the road.
2. 'Road narrows' signs should be placed 100 metres in front of the work area at the side of the road.
3. 'Keep left' arrows\* should be placed in the centre of the road at the start of the work area.
4. Barriers should be placed behind the 'keep left' signs.
5. Cones should be placed at a spacing of 10 metres on either side of the work area.

\* Assumes driving on the left.

6. 'Road clear' signs should be placed 200 metres beyond the ends of the work area at the side of the road.

When the work has been completed, signs should be removed in reverse order. Signs must not be left on the road or at the roadside overnight. They should be removed and returned to the depot.

### 3.5 DIVERSIONS

A diversion will enable maintenance work to be carried out more efficiently and more safely. In particular, diversions are needed for regravelling work and major culvert repairs. If traffic is to be diverted for more than a day or two, or the work is being carried out during the wet season, the diversion should be constructed with an adequate base and surfaced with gravel. A small gang should be allocated to keep the diversion in good condition. Diversions should be wide enough to allow two lorries to pass.

After the diversion has been completed and before work starts, warning signs, barriers and cones must be placed around the work area. The layout shown in Fig. 5 is recommended. Signs must be placed in the following order:

1. 'Men working' signs should be placed 200 metres in front of the work area.
2. 'Turn left/right ahead' arrows should be placed 100 metres in front of the work area.
3. Cones should be placed diagonally across the road to lead into the diversion.
4. 'Keep left/right' arrows should be placed at both ends of the lines of cones.
5. Barriers should be placed behind the lines of cones.
6. 'Road clear' signs should be placed 200 metres beyond the ends of the diversion.

Diversions will usually be in operation at night as well as by day and the approaches must be adequately lit. Kerosene lanterns may be adequate on lightly-trafficked roads or where speeds are low but high-intensity lamps should if possible be used on heavily trafficked roads. A watchman should always be in attendance to ensure that the lamps are working and are not interfered with or stolen. Lamps should show a yellow light. Flashing lamps are best as they consume less power and are more easily seen.

When the work has been completed, signs should be removed in reverse order.

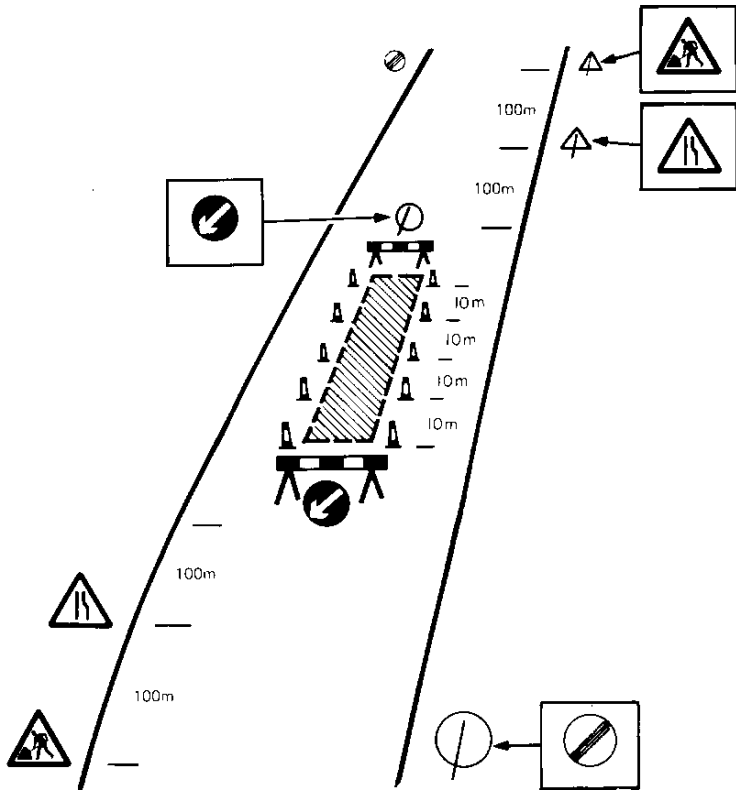

**Fig.4 Sign layout for centre line working**  
(drawn for driving on the left)

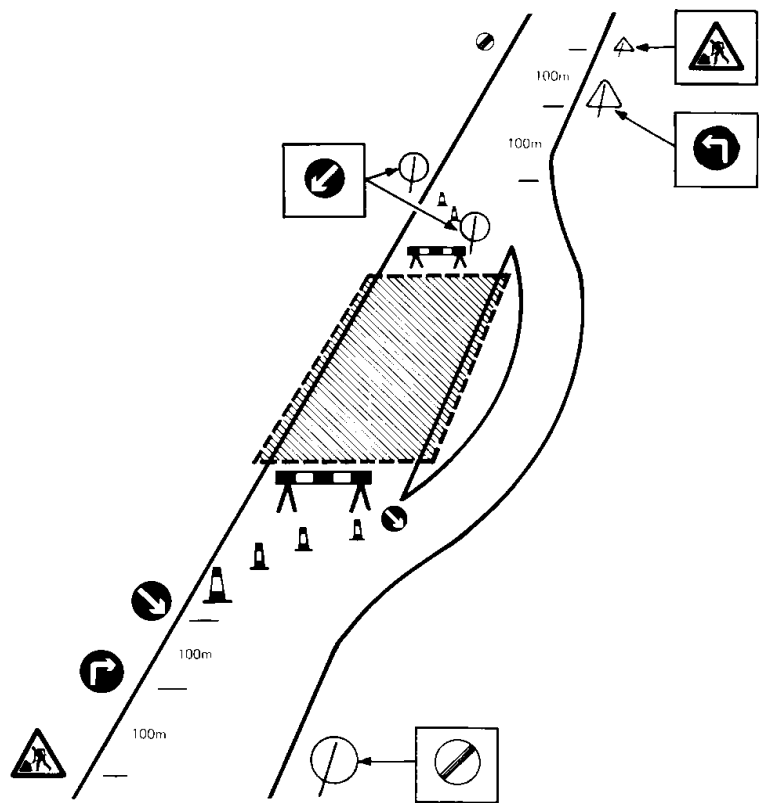

**Fig.5 Sign layout for diversion** (drawn for driving on the left)

### **3.6 DEVELOPMENT OF SAFETY MEASURES**

In many developing countries, no safety measures are provided at all during maintenance works. The Maintenance Engineer must understand that the safety of his workers and of the road user during maintenance operations is his responsibility. He must train his staff in methods of signing and traffic control and make them understand the need for safe working.

Initially it will probably not be possible to provide all the safety equipment recommended here. However, simple signs can be easy and cheap to make and it is possible to improvise cones and barriers. Turfs of grass cut from the roadside can be used instead of cones and effective road markers can be made from old oil drums painted with black and white bands and filled with sand, stones or water. If signs cannot be provided, a maintenance vehicle should be parked on the road between the on-coming traffic and the maintenance workers with its lights switched on.

When traffic volumes are very low, the Engineers may allow his workers to relax these standards. In particular it may not be necessary to use 'stop/go' signs. However, by relaxing standards, road users and maintenance workers must not be placed in a hazardous position.

## **4. MAINTENANCE OF ROAD FURNITURE**

### **4.1 TRAFFIC SIGNS**

Traffic signs are the principal means of conveying information about the road to drivers and, as the road network becomes more extensive, the number of traffic signs increases. As traffic flows increase, an increasing effort on their maintenance is needed.

The sizes, colours and layouts of signs have, in most developing countries, been standardised in accordance with international protocol and incorporated in Departmental standards. It is important that all signs should comply with these standards.

Signs which are clean and in good repair can be easily seen and understood and inspire confidence, that their message is accurate and reliable. Damaged or missing signs should, for the same reasons, be replaced promptly. Signs which are no longer needed (e.g. because of road improvements) should be removed, as should temporary signs upon completion of the maintenance works to which they are related. The provision and care of signs is very cheap and cost effective.

Signs should be inspected and cleaned at least twice a year. If there are enough signs, it may be worth setting up a small team which tours the District, covering all roads in rotation, which carries out this work as well as repainting posts and replacing damaged signs. The cleaning and inspection team will need to be provided with equipment such as that listed in Section 4.4.

Major repairs, particularly to sign faces, are better carried out in a central workshop which is equipped to do this work under good conditions and supervision. (This is particularly important in relation to signs which have legal force.)

It is worthwhile keeping records of traffic signs; they should be included in an inventory and transferred to a signs register (which may be a card-index) in which inspections, repairs and replacements are recorded. It is useful if their location is recorded on a strip-map.

### **4.2 RAILS AND POSTS**

Guard rails and parapet rails are provided to protect road users guard rails to prevent vehicles from running over high embankments and parapet rails on bridges to safeguard pedestrians. They should be repaired promptly if damaged, and kept clean and repainted regularly so as to maintain their visibility and prevent corrosion.

Kilometre posts provide both drivers and the maintenance organisation with the basic reference for the position of any point on the road. Kilometre posts

should be kept clean and repainted regularly, and vegetation should be cleared so that they can easily be read from a moving vehicle.

Similar requirements apply to bridge and culvert marker posts. It is recommended that each bridge and culvert is provided with a marker post (or posts), serially numbered within the kilometre in which it is located, thus: 79/3 is the third culvert or bridge in km 79. These numbers should be used as references in the culvert and bridge registers.

Delineator posts are usually provided only on bends. They should be kept clean and repainted regularly, preferably with reflective paint if reflectors are not fitted. Vegetation should be cleared so that they can be easily seen.

### 4.3 WHITE LINES AND REFLECTIVE STUDS

White lines are being used increasingly on principal two-lane roads in developing countries for centre line, lane and edge markings, and for 'stop' or 'give way' lines. They are particularly useful as an aid to night driving. A note on their maintenance is therefore appropriate.

White lines may be of paint or hot-applied plastic. Both materials may be reflectorised with small glass beads (ballotini). Emulsion paint gives a good performance on surface dressed roads with a good surface texture but, on premix roads or roads with less texture depth paint has a short life (perhaps only a few months under heavy traffic) and will require renewing regularly. Hot-applied plastic has a much longer life and should require much less maintenance effort. Its application requires the use of specialised equipment and properly trained operators. Paint, on the other hand, can be applied manually, although this will be a very slow procedure and the use of a portable paint sprayer is preferable. Whichever method is used, road markings should always be applied using templates or a straight edge. Such equipment will usually be provided through the central equipment organisation.

Reflective road studs may be used in conjunction with white lines. They should be replaced promptly if they are lost or damaged and protected by masking when surface dressing is being carried out. They should be installed by men who have been suitably trained. Particular attention should be paid to safety measures when men are working in the middle of busy roads (see Section 3.4).

## 4.4 MAINTENANCE GANGS

The composition of a typical road furniture gang is given below. Such a gang would be responsible for field repairs to traffic signs, guard rails, parapet rails, marker and delineator posts. They should also be responsible for cleaning signs. The Maintenance Engineer may find that local circumstances mean that a different composition with different tools and equipment are needed.

### Personnel

- 1 Overseer/Gang leader
- 1 Driver
- 2 Labourers

### Vehicles and equipment

- 1 Truck or van, equipped for carrying signs without damage
  - Assorted signs
  - Assorted tools, including spanners, etc
- 1 Pick-axe
- 1 Spade or shovel
- 1 Saw
- 1 Hand rammer Dry mixed concrete
- 1 Small ladder
- Water
- Detergent
- Paints
- Brushes
- Solvent for brush cleaning
- Safety equipment as recommended in Section 3.

A typical gang for road marking might consist of the following. These would be responsible for painting white lines and replacing reflective studs.

### Personnel

- 1 Overseer/Gang leader
- 1 Driver
- 2 Painters or labourers

### Vehicles and equipment

- 1 Small truck
  - Stencils
  - 30 metre tape
  - String
  - Paints
  - Brushes
  - Solvents for brush cleaning
  - Safety equipment as recommended in Section 3.2.

If thermoplastic paint is being used, it must be applied using a specially equipped truck and skilled operators in place of the painters or labourers. The truck should be painted yellow or orange and be equipped with flashing yellow warning lights.

## 5 MAINTENANCE OF DRAINAGE, SHOULDERS AND SLOPES

### 5.1 THE DRAINAGE SYSTEM

One of the most important aspects of the design of a road is the provision made for protecting the road from surface water or ground water. If water is allowed to enter the structure of the road, the pavement will be weakened and it will be much more susceptible to damage by traffic. Water can enter the road as a result of rain penetrating the surface or as a result of the infiltration of ground water. The road surface must be constructed with a camber so that it sheds rain-water quickly and the formation of the road must be raised above the level of the local water table to prevent it being soaked by ground water.

Water can also have a harmful effect on shoulders, slopes, ditches and other features. High water velocities can cause erosion which, when severe, can lead to the road being cut. Alternatively, low velocities in drainage facilities can lead to silt being deposited which, in turn, can lead to a blockage. Blockages often result in further erosion.

A good road drainage system, which is properly maintained, is vital to the successful operation of a road. It has four main functions:

- (i) to convey rainwater from the surface of the carriageway to outfalls (streams and turn-outs);
- (ii) to control the level of the water table in the subgrade beneath the carriageway;
- (iii) to intercept surface water flowing towards the road;
- (iv) to convey water across the line of the road in a controlled fashion.

The first three functions are performed by side drains and the fourth by culverts, drifts and bridges.

Common drainage problems include:

- (i) blocking of drains by debris or vegetation;
- (ii) silting: the deposition of silt in the bottom of drains and culverts, often reducing the gradient;
- (iii) erosion of the bottom of side drains in erodible soils or on steep gradients, particularly where insufficient turn-outs result in large flows in drains;
- (iv) erosion at culvert outfalls, resulting from high discharge velocities;
- (v) erosion of shoulders and side slopes.

Even if the drainage system of a new road has been carefully designed, it is likely that for several years after construction it will be necessary to observe its performance closely and to make additions and amendments to it. Reference is therefore made here to design matters where these can be seen as forming part of the maintenance function.

Both in the design and in maintenance of drainage, it is important to interfere as little as possible with the natural flow of water. Culverts on natural water-courses should follow the existing alignment as closely as practicable and re-alignment (often resulting in sharp changes in direction) should be avoided. The surface flows in drains and culverts should also be kept to a minimum by the use of frequent turn-outs where side drains cannot be discharged to existing water courses. In side-long ground, where discharge from the side drain on the high side passes to the low side, it is best to use frequent small culverts rather than occasional large ones. In such cases, the spacing will be governed by the maximum flow acceptable in the side drains and the capacity of the culverts will not usually be a constraint as the minimum requirements for access for maintenance (often taken as 600mm diameter or 600mm x 600mm box) will ensure adequate capacity.

### 5.2 SIDE DRAINS

The level of the water table beneath the carriageway is a major influence on the strength of the subgrade. The bottom of side drains should normally be maintained at a level at least one metre below formation level (the underside of the sub-base). If side drains have been constructed too shallow and they are not performing properly, they should be deepened as part of the maintenance operation. The performance of side drains should be monitored over time by the Maintenance Engineer to determine designs and dimensions appropriate to local topographical, climatic and soil conditions.

Side drains are usually built to the same gradient as the road. This may result in high velocities and erosion on steep gradients and silting on flat or reductions in gradient. Volumes in the side drains can usually be reduced by constructing frequent turn-outs.

In highly erodible soils, additional measures may be needed to prevent or control erosion. Grass should be encouraged to grow in drainage ditches as this helps bind together the topsoil and inhibits erosion. Where the erosion is only just starting, the most effective control is likely to be to dam the side drain at frequent intervals and to construct additional turn-outs. More severe erosion may need check-dams as shown in Fig. 6.



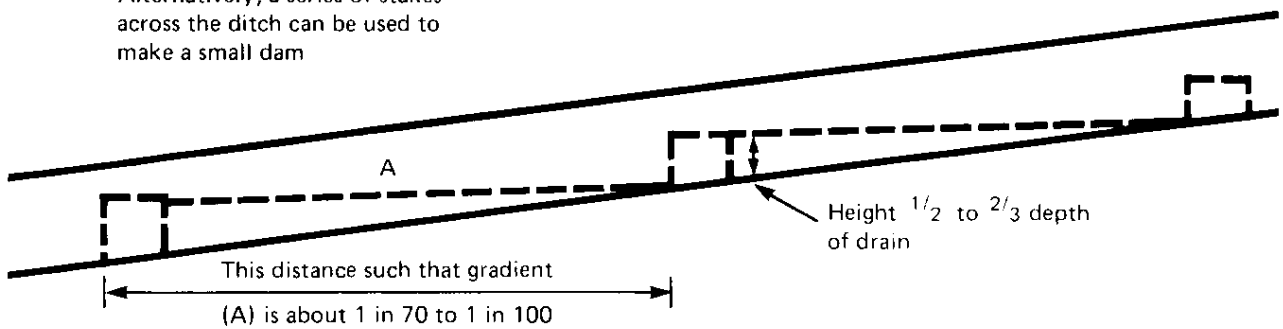
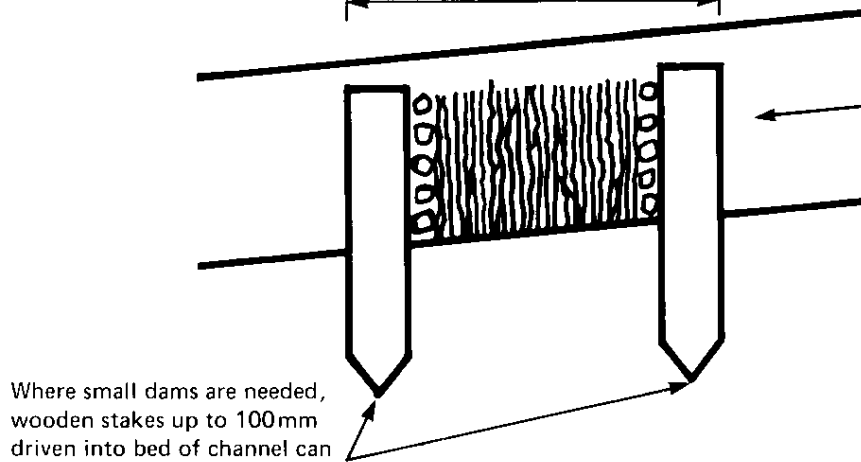
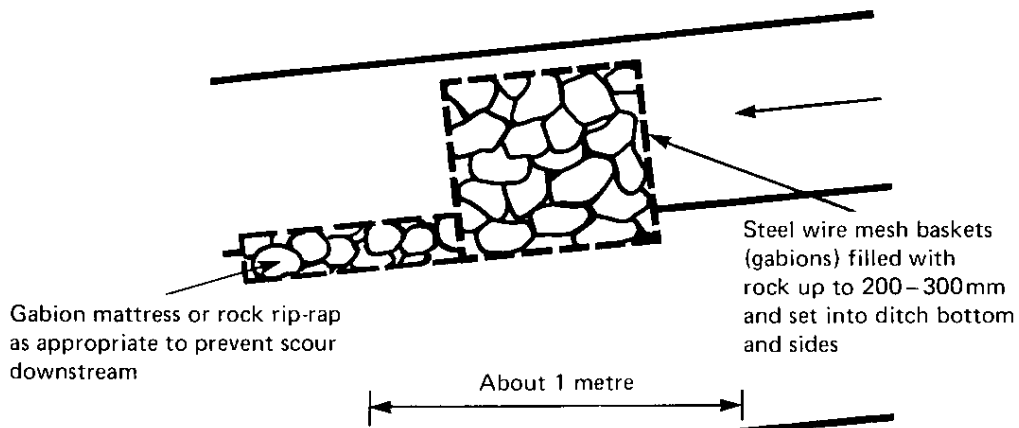
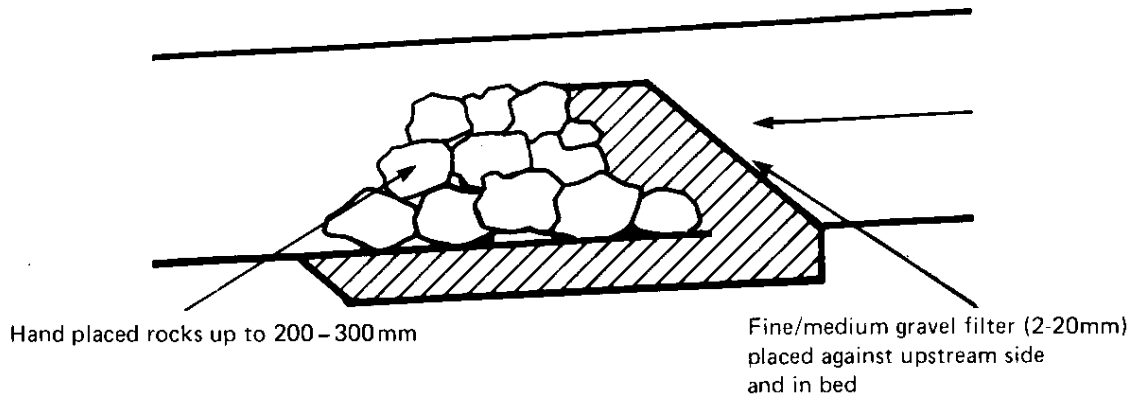

Fig.6 Check-dams for side drains

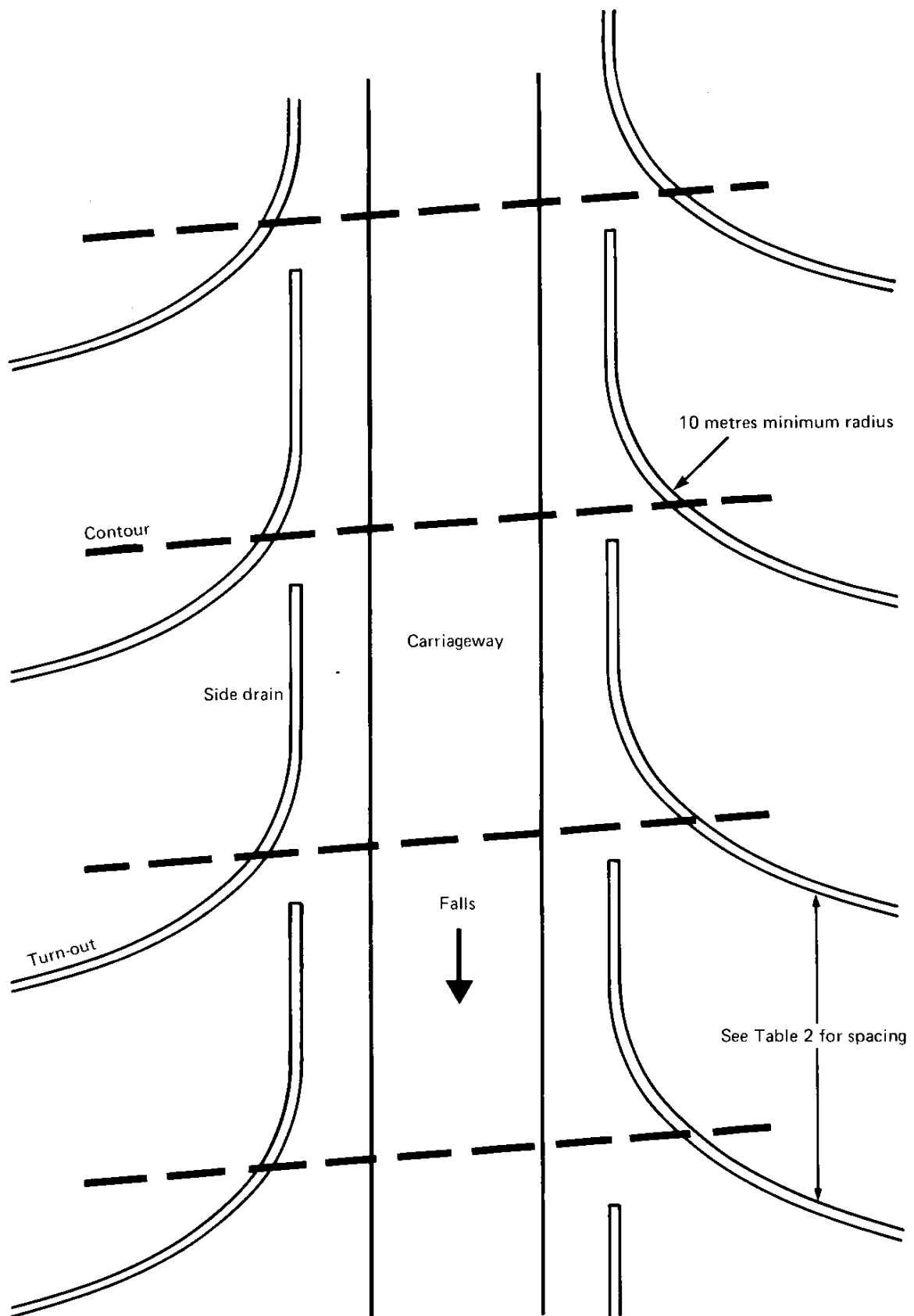

Fig.7 Layout of turn-outs

Dumping rock into an erosion gully is not usually effective unless a filter of finer material is also used. Rocks in steel wire mesh baskets or gabions may be more effective. These are shown in Fig. 6. Gabions should be extended well into the sides of ditches to prevent scour around their edges. Protection should also be provided at the foot of check-dams either by rock rip-rap or gabion mattresses as found appropriate. In very steep sections on highly erodible soil, it may be necessary to line the ditch with concrete, masonry or rip-rap. In time, erosion prevention measures may themselves require repair.

Removal of silt should form part of the routine maintenance programme. Silt should be thrown at least two metres clear of the side drains away from the road. It must never be used to repair road surfaces. If silting of side drains persists, it may be advisable to realign the ditches to increase water velocities, if this is possible.

The discharge from side drains should, wherever possible, be taken to existing natural watercourses. Where this is not possible, the side drains should be interrupted at intervals by dams, and the flow discharged to turn-outs (see Fig. 7). Here the water will be dispersed by seepage, evaporation, or by surface flow. Turn-outs should be built so that they have a longitudinal gradient of about 1 in 50 to 1 in 100 (ie. nearly parallel to the contours) and of such length that they run out to zero depth. The spoil from turn-outs should be thrown to the low side. The junction of the side drain and the turn-out should have a radius of at least five metres. This avoids the tendency for scour to occur at this point. Spacing of turn-outs depends on several factors including the erodibility of the soil, the width and gradient of road and cross-slope of the ground. On highly erodible soils, the spacing may initially be based on those indicated in Table 2. Spacings may be increased on soils with greater resistance to erosion. Observation of the performance of the side drains and turn-outs in practice will indicate if any changes are necessary.

**TABLE 2**

**TURN-OUT SPACING**

Gradient	Spacing (metres)
1 in 100 or less	50
1 in 100 to 1 in 50	40
1 in 50 to 1 in 20	25
1 in 20 to 1 in 10	15
more than 1 in 10	10

In agricultural areas, the construction and maintenance of turn-outs can cause difficulty with farmers. The matter should be discussed at the outset with the farmer as it is often possible to integrate road and farm drainage. In the last resort, it may be necessary to ask for the assistance of the Civil Authorities. Compensation may need to be paid.

Turn-outs should receive the same attention as side drains during maintenance. Both can be maintained by hand or with a grader. The cross-section of the ditch or turn-out determines the most appropriate method of maintenance.

The use of cut-off drains should be avoided as they sometimes cause small land-slips. Because they are often difficult for maintenance crews to locate, they are often neglected and become ineffective.

### **5.3 FORDS AND DRIFTS**

Fords and drifts are often used on lightly trafficked roads at watercourses with seasonal flows. They may be covered by deep water for short periods when traffic may not be able to pass, or by shallow water for longer periods. For much of the year they may be dry.

Maintenance of fords and drifts should be carried out after flooding and much of it consists of maintenance to carriageway, earthworks and culverts as for a normal length of road. In addition, warning signs, marker posts and depth indicators should be checked, and repaired or replaced as necessary. The crossing should be checked to ensure that the carriageway has not scoured or washed out, and any damage should be repaired. Erosion downstream of the ford is a common problem and, if necessary, a masonry or concrete apron should be constructed. An alternative may be to use stone gabions or mattresses. Any silt or debris must be cleared from the carriageway.

Some drifts have a culvert passing under them. These can cause the deposition of silt up-stream of the drift which tends to block the entrance to the culvert, making it inoperative. If culverts are used in drifts, they should be large enough and steep enough to be self-cleaning.

### **5.4 CULVERTS**

Culverts are provided to convey water from the upstream side of the road to the downstream side. They may be built on the line of existing watercourses or to carry the build-up of water which results from the presence of the road. In either case, silting, choking by debris or structural collapse will usually result in over-topping and damage to the road. Maintenance comprises keeping the waterway clear, controlling scour and repairing structural damage.

Erosion of outlet channels from culverts is a common problem and if not dealt with promptly is likely to result in damage to the culvert and the road. This is caused by high discharge velocities from the outlet, and solutions which do not take account of this are not likely to be permanently effective. If the discharge velocity cannot be reduced by increasing the area of cross-section of the culvert and reducing its gradient, perhaps with a drop-inlet, then some type of energy-dissipating outlet should be used. As a first step, a fan discharge constructed with masonry or concrete should be tried. Stone gabions or mattresses downstream of the outlet may be a cheap alternative. Drop outlets are good, but on many sites there is insufficient height to construct these.

The checking and removal of debris from culverts can be difficult, particularly if the culverts are small. Long-handled shovels or shovels attached to rods are useful for clearing out culverts which are too small for a man to get inside. Trees or branches blocking culvert entrances should be sawn into convenient sized pieces to help their removal and carting away. Culverts which get regularly blocked by debris should have a grill constructed at their upstream entrance.

Culverts made with corrugated metal pipes can be abraded by water carrying silt and sand which can wear away the protective zinc coating. This will result in the culvert pipe rusting away. If the culvert is large enough for a man to enter, the rust can be removed with a wire brush and the pipe coated with a thick layer of hot bitumen or tar. Alternatively, a flat concrete invert can be constructed.

Culverts made from concrete rings can be subject to differential settlement. This is a construction fault and major settlement problems can only be corrected by reconstruction. Minor mis-alignments should be repaired by grouting the joints in the pipes with concrete to provide a waterproof seal.

## 5.5 BRIDGES

Bridge inspection and maintenance requires specialist knowledge and skills, some of which will only be held by a qualified bridge engineer. The maintenance of large bridges is beyond the scope of this Note. However, some repairs to small bridges can be accomplished by a normal road maintenance unit and notes on these are included here.

The maintenance of the waterways under bridges involves the same principles as that for culverts. The main operations involve keeping the waterway clear, controlling scour and repairing structural damage. Maintenance methods are similar to those described under the maintenance of side drains, fords, drifts and culverts (Section 5.2 to 5.4). Debris should be removed

as soon as possible after floods, and eroded and scoured areas should be repaired. These should be filled with compacted gravel and then protected with rip-rap, concrete or gabions. Deposits of silt and sand should be removed where necessary to restore the original channel.

Simple repairs can be carried out to the decks of timber bridges. Loose planks can be re-fixed using screws or nails whose length is two or three times the thickness of the plank. Defective planks should be replaced with new planks of the correct thickness, length and width, which should be treated with wood preservative. All nail heads should be driven flush with the surface. Whenever planks are replaced, the condition of the timber underneath should be checked.

Small painting jobs can be undertaken such as the repainting of railings or, occasionally, steel beams. All dust, dirt, rust and old paint scale should be removed, where possible with an oxy-acetylene burner, and then with a wire brush. The steelwork should be given coats of primer, undercoat and topcoat. Only good quality paint should be used and it should be brushed thoroughly into the steel. Ample time should be allowed between coats for the paint to dry. Brushes should be washed thoroughly after use with thinners, petrol or kerosene. The colour of the topcoat should be as bright as possible for better visibility and safety.

## 5.6 SHOULDERS

Shoulders provide lateral support for the carriageway. They also provide accommodation for stopped vehicles and, on narrow roads, provide room for passing vehicles. Besides being used by vehicles, they are also used by pedestrians, cyclists and for animal driving. Shoulders may be paved, gravel, earth or may be grassed.

Paved shoulders are subject to the same type of defects as paved carriageways and are repaired using the same methods as described in Section 7 (Maintenance of paved roads). It will usually be convenient to carry out repairs to this type of shoulder at the same time as the repairs to the carriageway with the same maintenance gang. Periodically, it is necessary to reseal shoulders and this should be carried out in the same way as for manual surface dressing (Section 7.6).

Similarly, maintenance of earth and gravel shoulders is essentially the same as for unpaved roads. Most defects are corrected by grading, although ruts and pot-holes can be repaired manually (see Section 6.5). One of the objects of grading is to retrieve gravel lost to the shoulder and place it back on to the carriageway. On no account, must sediment from the ditch be graded on to the shoulder. The grader should cut to the bottom of all defects in the shoulder and spread the material so that, when compacted, it is level with the carriageway edge and slopes away to the ditch at a

steeper crossfall than the carriageway. For unpaved roads, this grading should be carried out at the same time as grading of the carriageway and in the same way (see Section 6.2).

If shoulders are worn away by the action of traffic and the level falls below that of the carriageway at the edge, water can collect at the edge of the road and infiltrate the base. This considerably weakens the structure of the road and usually results in severe deformation of the carriageway. In the case of paved roads, the edge starts to disintegrate and break away. This type of edge damage is difficult to repair effectively, but must be patched using methods similar to those described in Section 7.4. Edge repairs must be accompanied by the placing and compacting of new material on the shoulder or the repairs will be ineffective. Periodic regravelling of the shoulders should be carried out in a similar way to that described in Section 6.4.

Grassed shoulders can cause problems if the grass traps material washed off the road, leading to the shoulder level building up and trapping water at the edge of the carriageway. If this occurs, the shoulders should be graded-off as described above. Where there are bushes and high grass growing on the shoulder which interfere with lines of sight, these should be cut back as short as possible. This can be done using a tractor-mower or by hand using scythes and cutlasses. Where there is much road side furniture, hand cutting will be easier than using a machine.

When there is extensive damage to shoulders as a result of erosion or washouts, repairs are needed urgently and should be carried out as described in Section 5.7.

## 5.7 SLOPES

For all slips and settlements of cut and fill slopes which affect the road, the maintenance gang should place warning signs, cones and barriers around the site according to the layouts described in Section 3. Severe damage, where the road is cut by a landslide or a washout will usually have to be repaired by special gangs often needing heavy construction equipment. Less severe damage can often be repaired by the maintenance gang. Although slips and settlements can occur as a result of slopes being too steep, they are much more usually associated with the presence of water in the soil.

In the case of landslide material blocking the road, all the material should be removed and carted away on a tipper truck or on wheelbarrows and dumped where it cannot affect the road. Roadside ditches should be cleared of all debris and ditch shapes should be

reinstated. When shoulders have been cleared, their levels should be checked to ensure that water can flow from the carriageway uninterrupted into the drain. When the failed slope is not to be reinstated, the sides of the slip area should be rounded off.

Where there has been severe erosion or slips which have removed part of the carriageway or shoulder, or if erosion of slopes threatens the road structure, repairs are needed urgently. Loose material must be removed and the damaged area should be cut back to sound material. New material must be placed and compacted in 50-7 mm layers using small vibrating rollers or hand tampers. It may be necessary to add water to the fill material to assist compaction. When reinstating slopes in these cases, gab ions can be used for all or part of the repair work. In all cases, protection measures should be taken to stop the slip occurring again. This will probably involve improvements to the drainage system and may require paving of the slope itself using rip-rap, masonry or concrete. The use of gabions for filling material removes the need for slope protection. Establishing grass or other vegetation on the slope may be a cheaper form of protection. It may also be necessary to surface the shoulder with gravel or with a bituminous surface dressing.

## 5.8 MAINTENANCE GANG

For general maintenance work to drainage features, shoulders and slopes, the detailed composition of the maintenance gang will depend on whether the work is to be carried out by labour-intensive or equipment-intensive methods. A suggested basic gang size is given below, but this will need to change for different operations and situations, and the Maintenance Engineer should develop his own gang compositions to meet his own local circumstances.

### Personnel

- 1 Overseer/Gang leader
- 1 Driver
- Several labourers

### Vehicles and equipment

- 1 Small truck or tractor-and-trailer
- 1 Hand-held vibrating roller (0.25 Mg) plus a plank to help load onto truck or trailer, or one hand rammer for each labourer used on compaction work
- 1 Pick-axe for every two labourers
- 1 Broom for every two labourers
- 1 Shovel or hoe for every two labourers plus extension rods for culvert clearing
- 1 Rake for every two labourers
- 1 200 litre drum for water
- 1 Bucket or watering can
- 1 Axe
- Safety equipment as recommended in Section 3.

## **Materials**

Patching materials as indicated in Tables 3 and 4 for unpaved shoulders and slopes and as indicated in Tables 5-7 for paved shoulders.

Cement, sand and ballast may be needed for making concrete for repairs to culverts and paved ditches. Water, if not obtainable on site, must be carried.

Grass cutting work can be done by this same gang equipped with scythes and cutlasses or by a specially-equipped tractor mower. Shoulder grading should be carried out with a grader of at least 135 horse power working in conjunction with compaction equipment wherever possible.

## **6. MAINTENANCE OF UNPAVED ROADS**

### **6.1 TYPES OF MAINTENANCE**

The principal operation in maintaining earth and gravel roads is grading. Dragging or brushing may also be carried out with the objective of controlling the development of corrugations, and light or routine grading is also carried out for this reason. Heavy grading is used to reshape the road surface and to restore it to its correct camber or crossfall and to provide a smooth running surface. Heavy grading can be combined with regravelling to restore the thickness of the gravel surface. Filling or patching are labour-intensive operations to deal with the worst defects on low-volume roads for which the expense of grading or other machine activities cannot be justified.

### **6.2 GRADING**

#### **6.2.1 Types of grading**

Light grading is a light trimming of the surface of the road which should be carried out on a routine basis particularly in the dry season to control roughness and corrugations. When undertaking light grading in the dry season, loose material should be bladed towards the edge of the road. If several graders are available, it is more efficient to use them together on the same job. In this case, they should work one behind the other covering the whole width of the road. In the wet season, material should be graded towards the centre of the road. Light grading may be carried out by motor graders, but a more cost-effective technique is to use tractor-towed graders which are capable of similar outputs and standard of work on properly constructed roads.

Heavy grading consists of scarifying and cutting to the bottom of deformations and then reshaping the surface. It usually requires the use of a 135 horse power motor grader but, in some cases, the tractor-towed grader could also be utilised. Heavy grading operations should always be carried out at the beginning of the wet season to ensure that the road has the correct profile for effectively shedding water during the rains. When possible, it should also be carried out at the end of the wet season when the moisture content of the surfacing material is still high enough to help recompaction and prevent loss of fines. This is particularly important when heavy grading is needed to remove ruts and potholes. Scarifying to the depth required to remove these will result in the production of a considerable depth of loose materials and, in the dry season, this cannot be recompacted unless large amounts of water are added. The surface will then be

quickly deformed and fines will be scattered by traffic. Heavy grading of gravel is inadvisable without the provision of additional surfacing material if the remaining thickness of gravel is less than 75mm.

The frequency at which grading should be carried out will depend upon the traffic, the climate and the nature of the surface material. Gravels of average quality will probably need grading after 12,000-15,000 vehicle passes and good quality gravels may sometimes be left for 25,000 vehicle passes. For roads that are liable to corrugate, grading may be needed after the passage of only 1,500-2,000 vehicles. Some gravels, particularly those which are self-cementing or which contain large size material, are not suitable for grading as this results in the surface being torn up. Patching or regravelling is needed to repair these. The frequency of grading will also depend upon the daily traffic level as, at high traffic levels, a higher level of service may be expected, requiring more frequent grading. More guidance on the choice of grading frequency is given in Overseas Road Note 1.

### 6.2.2 Crossfall

Earth and gravel roads require steeper crossfalls than bituminous surfaces if rainwater is to be shed satisfactorily. If the grader operator has been trained on construction work for paved roads, it will probably be necessary to ensure that he understands the different requirements for unpaved surfaces. Crossfall on gravel and earth roads should be between 1 in 25 and 1 in 15 (4-6 per cent). It is very important to ensure correct camber on steep alignments. 'Flat' cambers are frequently the cause of the longitudinal gullying commonly found on such alignments.

Crossfall should be checked on site using a simple camber board, such as that illustrated in Fig. 8 which can be carried on the grader. Use of the camber board is illustrated in Fig. 9. It should be placed on its edge across the road with its narrower end pointing towards the centre line. If the level bubble is central, then the camber is correct. Checks

should be made at approximately 100 metre intervals along the road and if the camber is too steep or too flat, then the road must be graded again.

### 6.2.3 Steep hills

Steep hills on unpaved roads, where the longitudinal gradient is steeper than the crossfall, are prone to severe erosion in the wheel paths, particularly when these coincide in the centre of the road. Considerable attention must be paid to maintaining adequate cross-fall in these situations as this will minimise the erosion. If severe damage persists, consideration should be given to paving the gradient either by surface dressing or preferably with a concrete pavement.

### 6.2.3 Grader operation

The quality of workmanship in maintaining earth and gravel roads depends to a great extent on the skill and judgement of the individual grader operator. Careless operation can cause extensive damage to a road, for example by flattening the crown so that rainwater is not discharged, by cutting too deeply in dry weather or by blading plastic material from side drains on to the carriageway.

The Maintenance Engineer must get to know the ability of each grader operator and should find out the capability of each type of grader in use in his District. The manufacturers of graders publish manuals which explain the correct use of their machines in various applications and these should be obtained and studied by the Engineer. A particularly useful document is *Grading Illustrated* (Aveling-Barford, undated). With this information he will be better able to explain his requirements to grader operators and to ensure that they are carried out.

Arrangements must be made for graders to be checked mechanically, greased and fuelled before each day's work. The Maintenance Engineer must make operators understand the need for preventative maintenance of their machines and must try and ensure that equipment is not mishandled, misused or abused by operators in

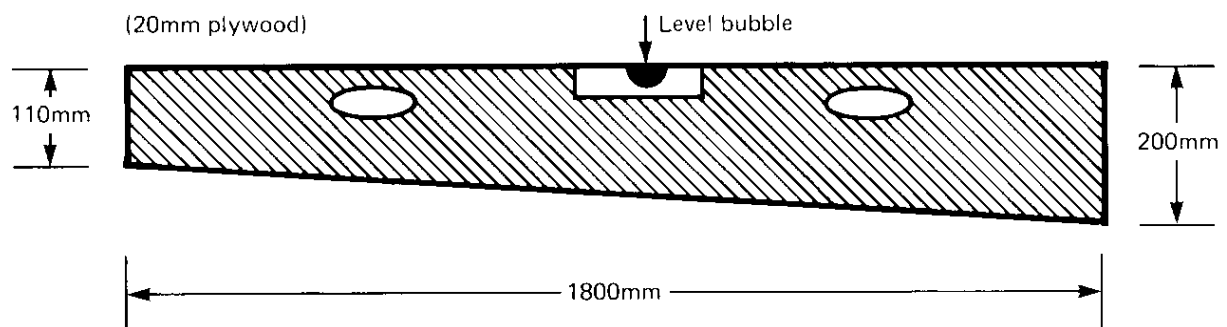
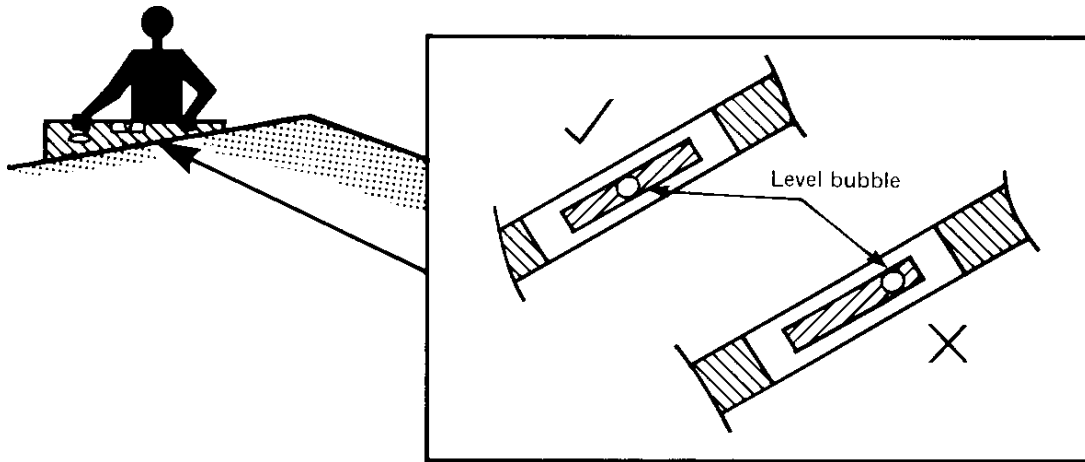
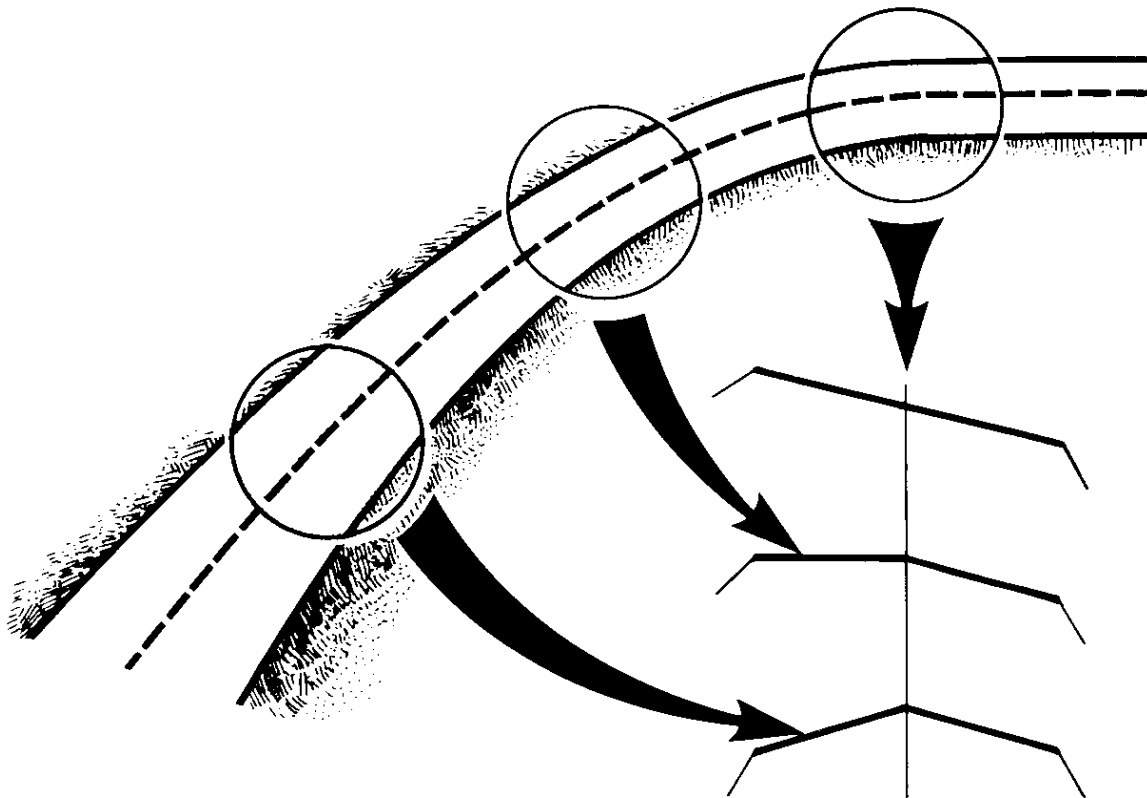

Fig.8 Five per cent camber board



**Fig.9 Use of camber board**



**Fig.10 Transition of camber on approach to bends**



the field. This can only be achieved by proper training and regular site visits by the Engineer. Arrangements may also need to be made to refuel graders on the job if necessary. This may be done either with a refuelling truck visiting the working site, or with an arrangement to refuel at a maintenance camp.

For heavy grading, the grader works on one side of the road at a time, if at all possible, and works in passes of about 200 metres in length. Graders must not stop on junctions or on bends where they will be a danger to traffic. On straight stretches of road the operator should aim to develop a crown on the road. The surface should be cambered to fall away from the crown with a slope of 4-6 per cent. The shape of the road must be maintained across culverts but, on sharp bends, the surface must be superelevated and must be flat from shoulder to shoulder with the outer shoulder higher. Any crown on a bend can be very dangerous to traffic. On the transition from bends in the road to straight sections, the camber on the outside lane should be gradually reduced until the normal cross-section shape is obtained again (see Fig. 10).

For heavy grading, it is important to cut to the bottom of surface defects and, if the road surface is hard, the grader's tines should be used to loosen the material. The grader should start from the edge of the road and work towards the centre. Gravelled shoulders should be treated as part of the running surface. The first and second passes cut to the bottom of the surface irregularity and deposit a windrow just beyond the centre line. If water is to be added, then the water tankers should spray the road at this point. The windrow is then spread back across the road depositing all the material on the carriageway to give the correct camber. The material may need to be sprayed again with water during this operation. After the camber has been checked, the other side of the carriageway is graded in a similar way to complete the work and leave a smooth even surface. This is illustrated in Fig. 11.

It is essential that the grader does not make a final pass down the centre of the road with the blade horizontal. This flattens the centre of the road and causes water to pond. This leads to rapid deterioration of the surface. Windrows must not be left in the middle of the road overnight as this is a danger to traffic.

If compaction equipment is available for use, it must follow up closely behind the grader but must only work on sections where grading has been completed to avoid interference with the grading operation. Rolling should start at the edge of the road and work towards the middle. Providing that the work is carried out in the wet season, watering of the road will not be necessary before rolling. Otherwise water should

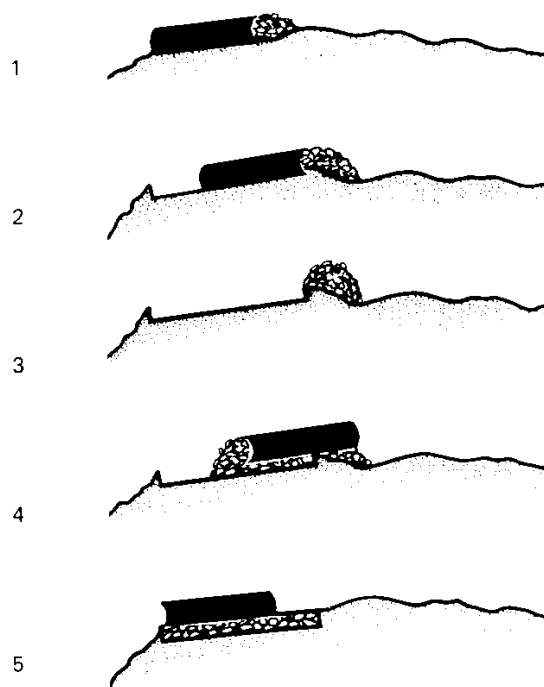

**Fig.11 Grading**

be added, as necessary, during the rolling operation to give the correct moisture content for compaction. The rollers should aim to progress from section to section at the same rate as the graders.

In the dry season, grading is essentially a dragging operation to remove loose dry material from the surface of the road and to fill in potholes and ruts (see Section 6.3).

#### **6.2.4 Grading gang**

For heavy grading, the grader needs to be powerful enough to cut to the bottom of the deformation in the road and a minimum size of 135 horse power is usually recommended. However, if the wearing course does not contain an excessive amount of oversize material, a tractor-towed grader could be used instead. The operator will normally be assisted by a machine attendant who helps direct traffic and grader turning, and removes large stones and other unwanted material from the path of the grader. He should work well ahead of the grader to stop it being delayed. The grader should carry a camber board and traffic signs as indicated in Section 3.2. Rollers should be used if available and water tankers should be used in conjunction with rollers if necessary.

For light grading, up to three graders can be used as this is more efficient for supervision, maintenance and refueling. The graders can be less powerful than those needed for heavy grading. Traffic signs should be used as described in Section 3.2.

All graders should be fitted with yellow flashing warning lights, and these plus headlights should be switched on when the graders are working.

## **6.3 DRAGGING AND BRUSHING**

Regular and frequent dragging can be used, in the dry season, to delay the formation of corrugations on earth and gravel roads by removing loose material from the surface. Dragging will not remove severe corrugations once they have formed, nor will it restore camber or lost material. These defects must be corrected by heavy grading.

### **6.3.1 Design of drag**

Typical drag units are shown in Fig. 12. The first consists of a metal 'A' frame constructed from 100 x 65 x 3mm channel on to which are bolted used grader blades. The leading one of these is angled to the direction of travel. The second unit is constructed from 100 x 75 x 3mm channel, but has additional blades for re-distributing the windrow. The approximate weights of these units are 250 and 375 kg respectively and they are relatively cheap to manufacture. Many other forms of drag have been used in various countries, such as railway rail, rolled steel joists, tolarads, timber baulks, etc. However, the two types illustrated in Fig. 12 are recommended because of their proven performance in quantified field trials and their ease of manufacture. They should be towed at speeds from 5-8 kilometres per hour and are capable of maintaining roads carrying up to about 100 vehicles per day. They are also effective for dealing with corrugations.

### **6.3.2 Brushing**

Brushing is generally effective only on very lightly trafficked roads with surfaces containing loose material. Typical tractor drawn brushes constructed from locally available material are shown in Fig. 13. The actual brushes used on the first type illustrated are made from brushwood tied tightly together. These must not be made out of old steel cable which is dangerous if broken off and left lying on the road. The tyre sledge illustrated consists of old tractor or heavy lorry tyres cut in half around their circumference and bolted or chained together. It is important that all the tyres are in contact with each other, as in the illustration, to ensure proper distribution of the loose material. Brushes made out of trees dragged behind a vehicle are not very effective for redistributing loose material on the road.

### **6.3.3 Method of operation**

The basic method of operation for both dragging and brushing is the same.

The frequency with which dragging should be carried out depends on the traffic loading, the rate of development of corrugations and the soil type. A road carrying 100 vehicles per day may need to be dragged every two weeks using the metal drags illustrated in Fig. 12. One dragging pass will probably be necessary every 3 to 4 weeks for roads carrying 50 vehicles per day and every four to six weeks for traffic levels of 25 vehicles per day. Simple experiments should be carried out by the Maintenance Engineer to determine the optimum frequencies for different conditions.

The drag should be designed where possible so that its width adequately covers half the road. This enables the maintenance to be carried out with a single pass in each direction.

For the best results, four main adjustments can be made according to the conditions; namely depth of cut, angle of cutting blades relative to direction of traffic, towing angle of drag and weight of drag. The drags illustrated in Fig. 13 have height adjustments at each end of the cutting blades and the position of the blades on the drag can also be changed to obtain the required volume of windrowed material. Varying the towing angle between tractor and drag can also achieve different volumes of windrows, but this is more difficult to control. The depth of cut can also be varied by weighting the drag. The level of surface roughness and size of the gravel wearing course will largely dictate the optimum weight of drag. However, the designs in Fig. 13 can still be utilised by changing the thickness of the channel sections.

The tractor or grader towing the drag should always work in the same direction as traffic and should not stop on junctions or on bends. Drags should be towed at speeds of 5-8 km/h depending on the type of drag and on the condition of the road surface. Care must be taken not to drive too fast or the drag will skip over the surface irregularities and will also generate a lot of dust. With brushes made of thorn scrub or brushwood, the operator must ensure that pieces which may break off the drag are not left lying on the road surface where they will be a danger to following traffic. Pass lengths should be as long as possible, preferably of the order of several kilometres.

### **6.3.4 Dragging gang**

Dragging can be carried out by a small crew of a tractor driver and/or grader operator and a machine attendant, depending on the availability of equipment. It is most

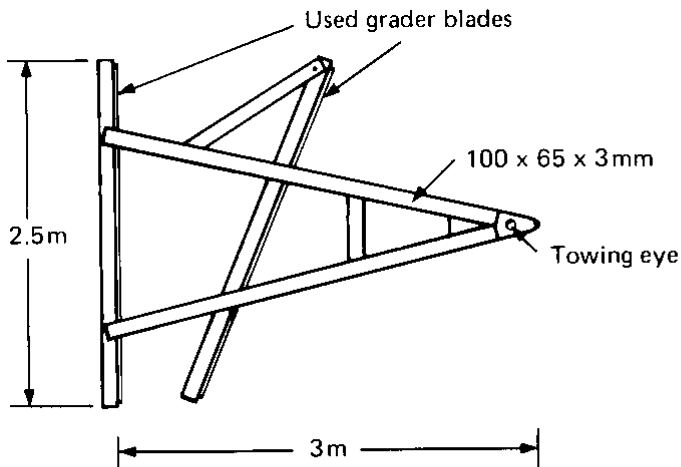
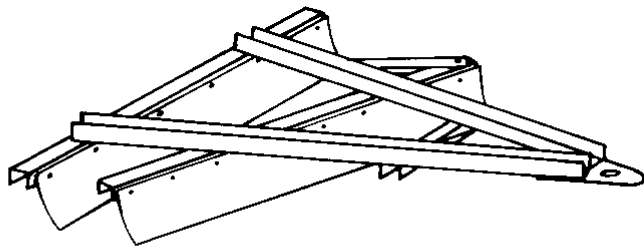

(a) 'A' - FRAME DRAG UTILISING GRADER BLADES

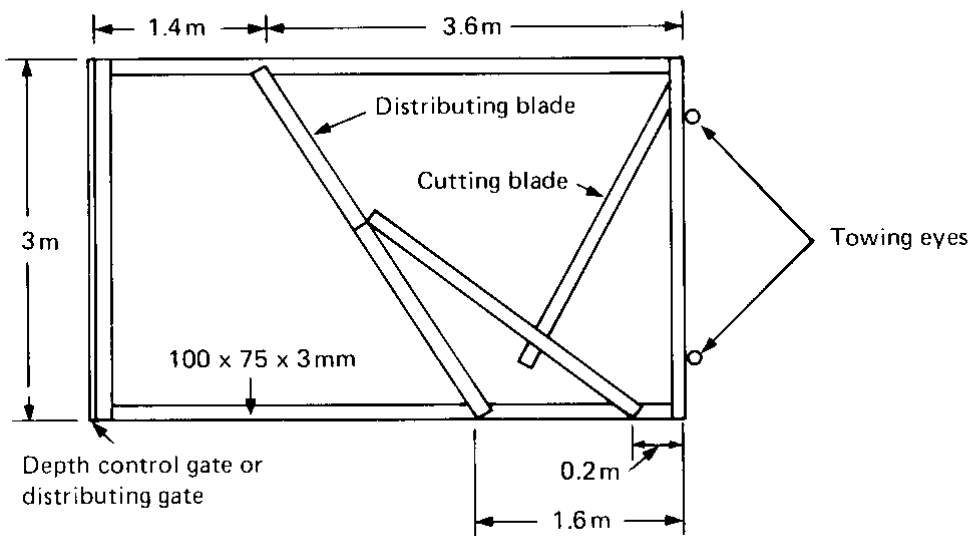
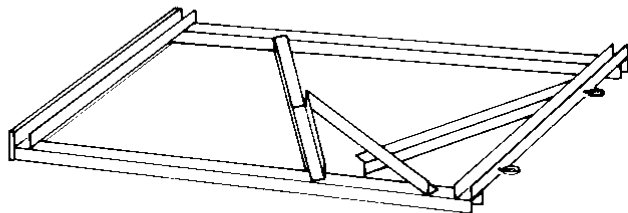

(b) RECTANGULAR TRIPLE BLADED DRAG

**Fig.12 Metal cutting drags**

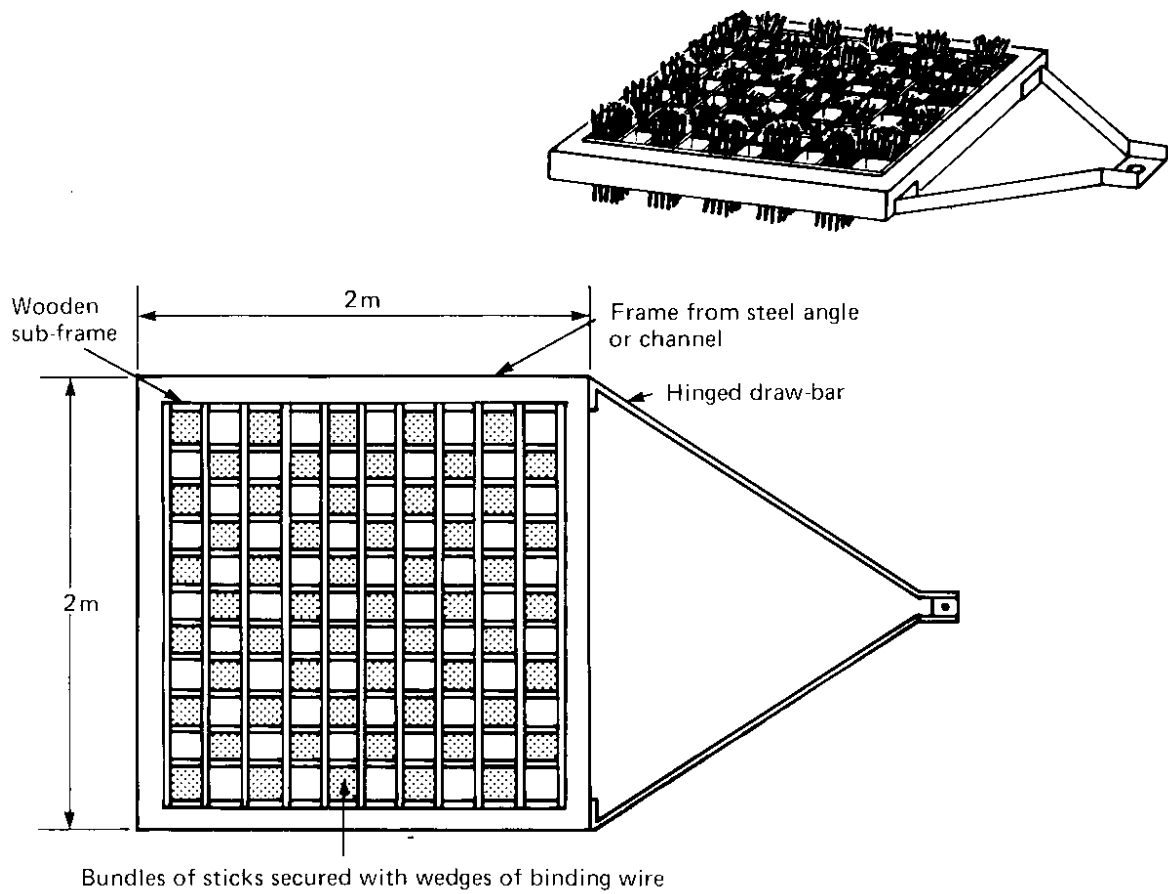

(a) BRUSHWOOD DRAG

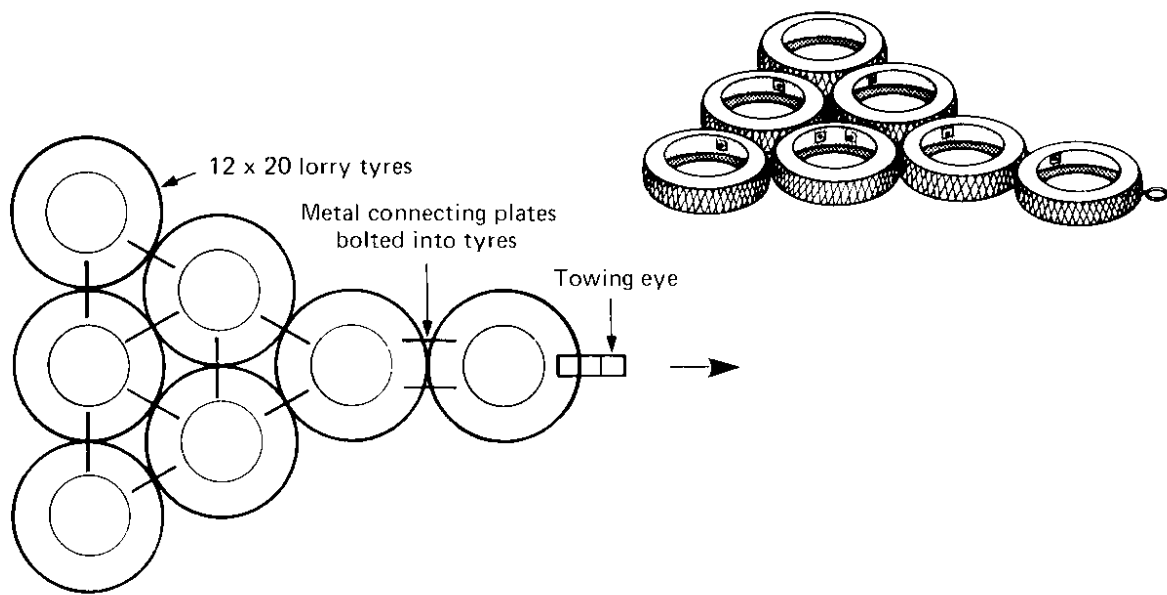

(b) TYRE SLEDGE

**Fig.13 Types of brush drag**

efficient to use several graders working in a team, one behind the other, spreading across the whole width of the road.

Machinery should, where possible, be fitted with flashing yellow warning lights, and these plus headlights should be switched on when working. If warning lights are not available, machinery should carry flags. Traffic signs should be used as described in Section 3.2.

## 6.4 REGRAVELLING

### 6.4.1 The task

The surfacing material of gravel roads is worn away by traffic, eroded by rain and blown away as dust. Where this occurs the subgrade will be exposed particularly in ruts and depressions. Before all the material has been lost and the subgrade loses shape and gets damaged, the road requires regravelling. Regravelling is also used to correct loss of shape, ruts, potholes and erosion gullies, when these have become severe.

Before regravelling work is carried out, it is important to make any necessary repairs or improvements to the drainage system of the road. If this is not done, the new gravel surface will deteriorate very quickly.

### 6.4.2 Quality of gravel

Most Roads Departments have standard specifications for gravels for surfacings (and for bases, where these are used). In practice, what is used will depend largely on what is available, and it may be necessary to use lower-grade material than is commonly specified. In dry climates, a fairly high proportion of clay binder is desirable to prevent the surface from ravelling and becoming corrugated. In wet climates, the presence of clay in the material is a disadvantage since it makes the surface slippery and prone to soften and rut under traffic. Suggested specifications in terms of grading and plasticity characteristics are given in Tables 3 and 4.

### 6.4.3 Organisation and equipment

Regravelling will be the major item of expenditure on the maintenance of gravel roads and its organisation should be carefully planned to ensure maximum efficiency.

The following will provide a basis for an estimate of the plant required for regravelling:

Gravel production:       1 bulldozer  
                                  1 loading shovel  
                                  1 grader  
                                  8 tipping lorries  
                                  6 labourers

**TABLE 3**  
**PARTICLE SIZE DISTRIBUTION FOR GRAVEL SURFACINGS**

B S sieve size	Percentage passing (*)		
	Nominal maximum size		
	37.5mm	19mm	9.5mm
37.5	100	-	-
19	80-100	100	-
9.5	55-80	80-100	100
4.75	40-60	60-85	80-100
2.36	30-50	45-70	50-80
425 $\mu$ m	15-30	25-45	25-45
75 $\mu$ m	5-15	10-25	10-25

(\*) Not less than 10% should be retained between each pair of such successive sieves specified for use, excepting the largest pair.

**TABLE 4**  
**PREFERRED PLASTICITY CHARACTERISTICS FOR GRAVEL SURFACINGS**

Climate	Liquid Limit not to Exceed (%) (*)	Plasticity Index range (%) (*)	Linear Shrinkage (%)
Moist tropical and wet tropical	35	4 – 9	2 – 5
Seasonal wet Tropical	45	6 – 20	3 – 10
Arid and semi-arid	55	15 – 30	8 - 15

(\*) Higher limits may be acceptable for some laterites or concretionary gravels that have a structure that is not easily broken down by traffic. Lower limits may be appropriate for some other gravels that are easily broken down by traffic. Any variation from these limits should be based on carefully collated local experience.

Production can be estimated as 450-500m<sup>3</sup>/day on a 5 kilometre average haul. If the haul exceeds 5 kilometres, additional lorries should be provided so that the other plant is fully utilised.

Regravelling:           1 grader  
                                  1 6/8 tonne steel-wheeled roller and  
                                  1 pneumatic-tyred roller  
                                  1 pneumatic-tyred roller and  
                                  1 pneumatic-tyred roller

2 water tankers, if water is available  
1 water pump  
1 lorry  
20 labourers

Production can be estimated as 300-350m<sup>3</sup>/day.

To provide 100mm of gravel on one kilometre of road 7.5 metres wide will require 750 m<sup>3</sup> of gravel (compacted volume) so that the above team could regravell about half a kilometre of road per day.

Well in advance of the work, a start should be made to stockpile gravel at the borrow pit or quarry. In addition, arrangements must be made to obtain water close to the regravelling site. Whenever possible, a bulldozer or grader should open up a diversion track adjacent to the road. If a traffic diversion can be opened adjacent to the work site, it will enable the job to be carried out more efficiently and more safely. If traffic is heavy, the diversion may need to be gravelled and a grader assigned to keep the surface in good condition. After the diversion has been completed and before the work starts, warning signs, barriers and cones must be erected around the work area as described in Section 3.5. If it is not possible to open a diversion, 'lane closed' signing must be used as described in Section 3.3.

#### 6.4.4 Spreading gravel

It is advisable to reshape the existing surface before placing additional material. If this is not done it is likely that existing deformation will be reflected in the new surface. A hard surface should be scarified with a grader to a depth of about 50 mm to ensure a good bond between the new and existing material. The edges of the road should be 'boxed-out' to provide support for the new material. The camber of the graded surface should be checked to ensure that it is between 4 and 6 per cent.

At the quarry, the tippers should be loaded for transport to site. The supervisor at the quarry should ensure that gravel is taken from the right place and that the trucks are loaded correctly. Tippers circulate continuously between the quarry and the site. Usually the gravel is supplied in advance and tipped in heaps on one side of the road at the correct spacing to give the required thickness of material when spread across the road. If the diversion has not been opened, material must be tipped onto the shoulder and warning signs placed at either end. If the gravel is fairly moist, this will not cause any serious problems, but dry gravel is likely to segregate during the loading, tipping and subsequent spreading operations. A better method of spreading gravel is to use a spreader box towed by a lorry. This is much faster than spreading using a

grader, but does require a continuous feed of lorries or the method becomes very inefficient.

Ideally, the moisture content of new gravel should be adjusted to optimum for compaction. In practice, this may be impracticable in view of the cost of providing, transporting and applying large amounts of water. However, it is usually possible to take advantage of the climate and to carry out regravelling work at the beginning of the dry season when the natural moisture content of gravel from borrow pits is close to optimum. It is important that the work is planned to obtain maximum benefit in this way. If additional water is required and available, the tankers should spray the road initially, before the new gravel is spread. The new gravel is then spread right across the road using the grader. The new material is alternately spread by the grader and watered by the tanker until its moisture content is correct for compaction. The tankers circulate continuously between the site and the source of water.

Once the material has been spread evenly across the road and it is at the correct moisture content, it should be graded to shape as described in Section 6.2.3. Finally, the camber should be checked with the camber board and, if the required standard has not been reached, the grading should be repeated.

#### 6.4.5 Compaction

Compaction should not be left to the action of traffic as this quickly becomes concentrated in the wheeltracks and leads to deformation of the road. Rollers should be used if available as, even though it may not be possible to achieve full compaction, the limited compaction obtained will improve the quality of the surface. Four passes of a roller will give a worthwhile degree of compaction at optimum moisture content, while eight or more will be needed to bring relative compaction up to that required.

Compaction should start as soon as the grader has finished a section. The rollers should start at the edge of the road and work towards the centre and continue rolling until full compaction has been achieved. This should be organised to finish at the same time as the grader finishes the next section. It is essential to check the thickness of the compacted layer.

#### 6.4.6 Continuous working

The work should continue along the road in sections. As each section is completed, the traffic signs, cones and barriers are moved along the road to the next section. This opens the road at the completed

end for traffic, and closes it at the other end to allow new gravel to be dumped. As the work proceeds, it will be necessary to open new diversions.

## 6.5 FILLING AND PATCHING

These are manual operations which can be used for repairs to the surface where defects develop on a small scale and heavy grading or regravelling is not justified. They can also be used when equipment is not available. They can be used to repair pot-holes, ruts, soft-spots and erosion gullies. The operations are sometimes known as spot regravelling. Patching may also be needed on self-cementing gravels or gravels containing large lumps of material as, in these cases, grading will only cause more damage to the surface. Filling and patching are not satisfactory methods of repairing corrugations and dragging or grading is needed to remove these. Where there are large numbers of pot-holes, the road will need heavy grading and possibly regravelling.

The quality of the material used should be the same as that used for regravelling (Tables 3 and 4). It should be stockpiled at the nearest maintenance camp or dumped by the side of the road near where it will be used.

Before work starts, signs must be set up as described in Section 3.3. Loose material and standing water should then be brushed from the area to be repaired. Large or deep pot-holes should have their sides cut back to be vertical and should be deepened to reach sound material. If the material is dry, the area to be repaired should be sprinkled with water and it is then also useful to mix the patching material with water as well. The patch should then be filled in layers of about 50-70mm at a time. Each layer should be compacted with hand rammers or with small vibrating compactors. It is not advisable to roll with the wheels of the truck or tractor as insufficient compaction can be obtained in this way. The layers of the patch should be built up in this way and, finally, the patch is filled with gravel to approximately 30mm above the level of the road surface and is spread and raked to the correct shape. The patch is then compacted to give a surface which is slightly above the level of the surrounding road. Both large and small areas are repaired in the same way.

Patching work started must not be left unfinished overnight. At the end of each day, tools and traffic signs should be taken back to the maintenance camp and the site must be left clean and tidy with no stockpiles of material left on the road.

Details of the maintenance gang and equipment needed for filling and patching work are given in Section 5.8. The District Engineer will need to modify this basic unit to meet his own local conditions and for different situations.

## 6.6 DUST PREVENTION

### 6.6.1 The dust problem

In the dry areas of many developing countries, unpaved roads are often affected by dust. This may have been generated by the interaction between vehicular tyres and the unbound surface or by the effect of wind. Dust is a maintenance problem because it results in the loss of material from the road surface which has to be replaced. It is a contributory factor to road accidents because of the reduction in visibility and it also pollutes the atmosphere close to the road.

It has been shown that well constructed and adequately maintained unpaved roads carrying 100 vehicles per day in dry areas can lose over 25 tonnes of dust per kilometre each year. In addition, it has been found that, when the wearing course contains an excessive amount of material finer than 10mm, the annual dust loss can be greater than 33 tonnes per kilometre. Losses on older roads with lower levels of maintenance will be much higher. This loss of material increases the permeability of the surface layer and results in the early development of pot-holes, all of which accelerate the need for regravelling.

### 6.6.2 Remedial treatment

The major types of remedial treatment for dust proofing unpaved roads are as follows:-

- (i) application of a bituminous seal
- (ii) chemical stabilisation and coating with deliquescent salts
- (iii) application of waste local materials such as oiled gravels, sulphur liquors, molasses, palm oil, vegetable oil, bamboo oil, lime, charcoal, etc
- (iv) addition of water.

With the exception of the bituminous seal, all of these treatments provide only temporary improvements. Many of the additives are soluble in water and will require renewal at the end of the rainy season. Apart from the use of local materials, most treatments are also expensive.

If dust treatment is being considered, careful costings should be carried out to ensure that the costs of repeated applications of the additive over several years are cheaper than the more permanent treatment by surface dressing.

## **7. MAINTENANCE OF PAVED ROADS**

### **7.1 TYPES OF MAINTENANCE**

Maintenance operations on paved roads can be divided into those used to repair local failures and those used to improve the whole carriageway.

Local surfacing failures such as cracking (without rutting), stripping and fretting may be repaired by local sealing. Fattening-up of bitumen over small areas is not a problem unless the bitumen is 'bleeding' when it should be repaired by sanding. Localised structural failure, where there is rutting and cracking, or pot-holing should be repaired by patching.

Whilst surface dressing is essentially a waterproofing operation some minor surfacing defects such as loss of texture, fine cracking and fretting can often be corrected by this process. An alternative to surface dressing is slurry sealing. This is almost always carried out by specialist contractors and only brief notes are given on it here. It is usually more costly than surface dressing. Sand sealing is a form of surface dressing, but it should only be used where there is a shortage of aggregate and an abundance of sand. Its use is not recommended in most cases and no notes are given on it here.

Reflection cracking sometimes occurs on roads constructed with cement or lime stabilised bases. It is characterised by a regular rectangular crack pattern and is caused by shrinkage of the base. It is not a sign of failure, but the surface should be sealed to keep out water. If the cracks are widely spaced (greater than 1 metre), they can be sealed with a bituminous binder. If they are closely spaced, it is probably better to surface dress.

Where there is extensive structural failure, the road will need to be overlaid or reconstructed. For overlays to be economical, they must be placed when the road is in a 'critical' condition and before complete failure has occurred. Such major repairs are very expensive and use techniques more similar to construction than maintenance. Their use is beyond the scope of this Note and they are not described.

### **7.2 LOCAL SEALING**

This may be used to seal relatively small areas of surfacing failure where the size of the works does not justify using a bulk bitumen distributor (eg. lengths of road less than 100 metres long). The method used will need to take account of the equipment, materials and men available to do the work.

Frequently the process relies on the manual application of binder using watering cans, hand-pumps and lances,

etc. Such considerations automatically limit the range of binders which can be used to bitumen emulsions and low viscosity cut-backs. Control of the bitumen application rate will often be poor and requires careful supervision by an experienced foreman. Uneven distribution of bitumen is a common fault when it is applied using hand-lances. Typical productivities for hand-spraying emulsion are 600-1000 litres per day for a unit of three men with one sprayer.

Cover aggregate should be of a small nominal size such as 6 mm chippings or coarse sand and should be lightly rolled.

This work should be carried out by the patching gang (see Sections 7.4.3 and 5.8).

### **7.3 CRACK SEALING**

This is used where reflection cracking has occurred and the aim is to fill the cracks as completely as possible with bituminous binder to keep out water.

The method and materials used will depend on the equipment available for the work. Viscous binders will need a hand-lance with a relatively fine jet capable of getting the binder into the cracks. The use of a watering can for viscous binders is not effective, besides being wasteful and untidy. If sophisticated spraying equipment is available, it should be capable of filling cracks with penetration grade binders such as 80/100 or 60/70. Less effective equipment can only use bitumen emulsion for sealing the cracks. Sealed cracks may be blinded with quarry fines.

This work should be carried out by the patching gang (see Sections 7.4.3 and 5.8).

### **7.4 PATCHING**

#### **7.4.1 Procedure**

The need for patching is usually the first sign of major pavement deterioration. It may be carried out on a recurrent basis or prior to the application of a surface dressing or overlay. The cause of the local failure that requires patching will often be related to problems of on-road or off-road drainage, and it is most important that these defects are identified and remedied before the patching operation begins.

With all patching work, it is important to remove the failed area entirely and to cut the road back to sound material. The sides and bottom of the patch should be squared-off to provide a firm coherent surface. Where bituminous patching material is to be used, the excavated and trimmed area should be carefully brushed, moistened slightly with water and painted with bitumen emulsion or rapid-curing cut-back so as to provide a good bond with the in-filling material.



Recommended materials for patching are described in Section 7.4.2. The material should be compacted into the hole in 50-70mm layers using hand-rammers or a small vibrating roller. The surface of the completed patch should be slightly higher than the road surface so as to permit final compaction by traffic. The patch should be sealed using bitumen emulsion or cut-back and blinded with sand, crushed rock fines or small chippings.

#### 7.4.2 Materials

The materials used for patching will depend on those present in the existing road. Recommendations are given in Table 5.

**TABLE 5**  
**RECOMMENDATIONS FOR PATCHING MATERIALS**

Layer	Existing material	Repair material
Base	Gravel	Gravel of at least as good quality as the original
	Cement stabilised, bitumen stabilised, crushed rock or bitumen macadam	Graded crushed rock plus fines, soil cement or premix macadam
Surface	Surface dressing (new, thin)	Seal with binder and small chippings
	Surface dressings which have built up to several centimetres thickness and premix surfaces	Premix macadam plus seal of binder covered with sand, crushed rock fines or small chippings

Specifications for suitable gravels, which may be used for patching, have been given earlier in Tables 3 and 4. These are also suitable for stabilisation with 5-10 per cent of cement. If crushed rock is used for the patching material, gradings can be again taken from Table 3 or alternatively from Table 6.

**TABLE 6**  
**ALTERNATIVE GRADING FOR CRUSHED ROCK PATCHING MATERIAL**

BS sieve	% passing
37.5 mm	100
20	80-100
10	55-80
5	40-60
2.36	30-50
600µm	15-30
75µm	5-15

Premix macadam should comply with the requirements given in Table 7.

**TABLE 7**  
**REQUIREMENTS FOR PREMIXED MACADAM USED FOR PATCHING MATERIAL**

14mm nominal size	
BS sieve (mm)	% passing
20	100
14	90-100
10	55-75
6.3	25-45
3.35	15-25
75µm	2-6
Binder content 4 – 5%	

The binder to be used for premix patching material will usually be a soft penetration grade bitumen or a fairly viscous medium-curing cut-back, such as MC800 or MC3000, depending upon local conditions and the possible need to stockpile patching material. Premix macadam patching material must be mixed using a pugmill-type mixer. This may be at a central mixing plant where quality can be most easily controlled, although purpose-built mobile mixers are now available to permit cold or hot-mixed material to be manufactured on site.

The mixes described above are adequate for small-scale patching work but, for larger-scale work, it is desirable to use higher-grade materials under close quality control.

#### 7.4.3 Patching gang

Details of the maintenance gang and equipment needed for patching work are given in Section 5.8. The District Engineer will need to modify this basic unit to meet his own local conditions and for different situations.

### 7.5 MECHANISED SURFACE DRESSING

#### 7.5.1 General principles

Surface dressing consists of spraying the road surface with a film of binder followed by the application of a layer of stone chippings which is then rolled. Surface dressing has three main purposes:

- (i) to seal the road surface against water,
- (ii) to prevent disintegration of the surface,
- (iii) to provide a non-skid wearing surface.

Surface dressing will not restore the riding quality of mis-shapen roads nor will it significantly strengthen the road structure.

The use of mechanised surface dressing methods offers important advantages over manual methods. Mechanical bitumen sprayers allow the close adjustment of rates of application so that these can be accurately controlled and the adverse affects of excessive, insufficient or variable amounts of binder can be avoided. The rate of progress of a mechanised unit is much higher than can be achieved by manual methods.

A separate document (TRRL Overseas Unit, 1982) gives detailed guidance for specialist surface dressing operations.

### 7.5.2 Design of surface dressing

The design should take into account the type of existing road surface, the traffic, the available chippings and the climate.

**7.5.2.1 Type of existing road surface** Before deciding on the specification for the surface dressing, a site visit is essential to assess the condition and hardness of the old road surface. For all practical purposes, surfaces may be divided into the following categories:-

TABLE 8

ROAD SURFACE TYPES

Very hard	Surfaces such as concrete or exceptionally lean bituminous mixtures with dry stony surfaces into which there will be negligible penetration of chippings under very heavy traffic.
Hard	Surfaces containing some hard bituminous mortar into which chippings will penetrate only slightly under heavy traffic.
Normal	Surfaces into which chippings will penetrate moderately under heavy and medium traffic.
Soft	Surfaces into which chippings will penetrate considerably under heavy and medium traffic.
Very soft	Surfaces into which even the largest chip pings will be submerged under heavy traffic. Such surfaces are usually rich in binder.

**7.5.2.2 Traffic categories** The volume of traffic that the road is required to carry is an important factor in the design of the surface dressing. Heavy vehicles embed chippings into the road surface and the amount of this embedment depends on the number and weights of these vehicles. Traffic should be considered in terms of the number of commercial vehicles a day in the lane under consideration. Lane traffic categories are shown in Table 9.

TABLE 9

LANE TRAFFIC CATEGORIES

Category	Approximate number of vehicles with unladen weight greater than 1.5 tonnes carried per day in the lane under consideration
1	Over 2000
2	1000-2000
3	200-1000
4	20- 200
5	Less than 20

**7.5.2.3 Chippings** The chippings should comply in all respects with the requirements of *BS 63: Specification for single sized roadstone and chippings* (BSI, 1971), the main points of which are summarised in Appendix A. Samples of the chippings to be used should be tested before the start of the work and subsequently as new deliveries are received. The sampling and testing should be in accordance with the methods described in BS 812 (BSI, 1975).

The size of chippings should be chosen to suit the amount of traffic and hardness of the existing road surface, as given in Table 10.

The quantity of chippings needed must be sufficient to cover the entire surface of the binder film after rolling. The most reliable way of ensuring a complete cover is to lay a slight excess of chippings. The rate at which chippings should be spread depends on their size, shape and specific gravity, but rates can be estimated using Fig. 14.

The least dimension of at least 200 chip pings should be measured, using the method described in Appendix A, and the 'Average Least Dimension' (ALD) determined. The Average Least Dimension is then entered in Fig. 14 to intersect line AB and the approximate rate of application of chippings can be read off. This rate should only be used as a guide for supply purposes; the actual rate of spread should be adjusted as required on site when the spreading characteristics of the chippings can be observed.

**7.5.2.4 Binder** Surface dressing binders should have a viscosity of between  $10^4$  and  $5 \times 10^5$  centistokes at the prevailing road temperature. At higher viscosities, stone will not be wetted by the binder and will be lost by whip-off. At lower viscosities, the binder will be too fluid to hold the stone. Figure 15 shows the viscosity/ road temperature relationship for a wide range of binders. Day time road temperatures in the tropics range generally from 30°C to 70°C, from which it will

**TABLE 10**  
**RECOMMENDED CHIPPING SIZE (mm)**

Type of surface	Lane traffic category				
	Approximate number of commercial vehicles currently carried per day in the lane under consideration				
	(1) Over 2000	(2) 1000-2000	(3) 200-1000	(4) 20-200	(5) Less than 20
Very hard	10 mm	10 mm	6 mm	6 mm	6 mm
Hard	14	14	10	6	6
Normal	20**	14	14	10	6
Soft	*	20**	14	14	10
Very soft	*	*	20**	14	10

\* Unsuitable for surface dressing.

\*\* 20 mm chippings may be used for remedial treatment where traffic speeds are low. Very particular care should be taken when using 20 mm chippings to ensure that no loose chippings remain on the surface when the road is opened to unrestricted traffic as there is a high risk of windscreen breakage.

Note:

The size of chippings specified is related to the mid-points of lane traffic category ranges 2-5: lighter traffic conditions may make the next smaller size of stone more appropriate.

**TABLE 11**  
**CONDITION CONSTANTS**

Traffic	Vehicles/day	Constant	Types of Chippings	Constant
Very Light	0-50	+3	Round/dusty	+2
Light	50-250	+1	Cubical	0
Medium	250-500	0	Flaky	-2
Medium Heavy	500-1500	-1	Pre-coated	-2
Heavy	1500-3000	-3		
Very Heavy	3000+	-5		
Existing surface			Climatic conditions	
		+6	Wet and cold	+2
		+4	Tropical (wet and hot)	+1
		0	Temperate	0
		-1	Semi-arid (dry and hot)	-1
		-3	Arid (very dry and very hot)	-2

be seen that the most appropriate binders are MC 3000 or penetration grades up to 80/100. The choice may be restricted in practice either as a result of Departmental purchasing policy or by what is commercially available.

In order to design the rate of application of binder, an appropriate constant should be selected from Table 11 for each of the four sets of conditions listed. The four constants are then added together to give the appropriate factor.

The Average Least Dimension of the chippings and the factor obtained from the condition constants in Table 11 are then entered in Fig. 14 to give the rate of application of binder.

### 7.5.3 Equipment

Few districts will have a length of bitumen-surfaced road large enough to justify a permanent, full-time surface

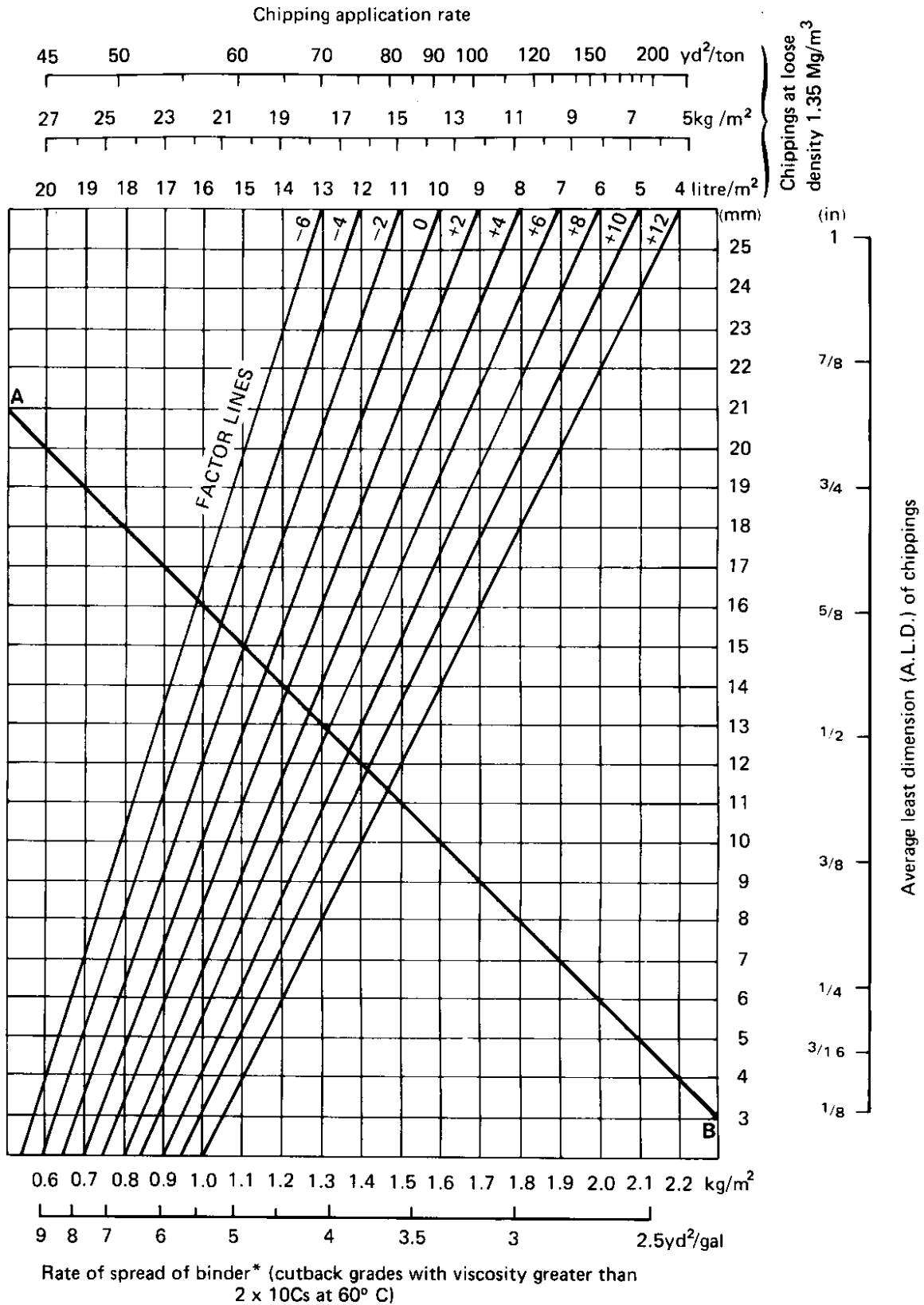

Fig. 14 Surface dressing design chart

- \*1 For slow traffic or climbing grades steeper than 3 per cent, reduce the rate of spread of binder by 10 per cent
- 2. For fast traffic or down grades steeper than 3 per cent increase the rate of spread of binder by 10 to 20 per cent

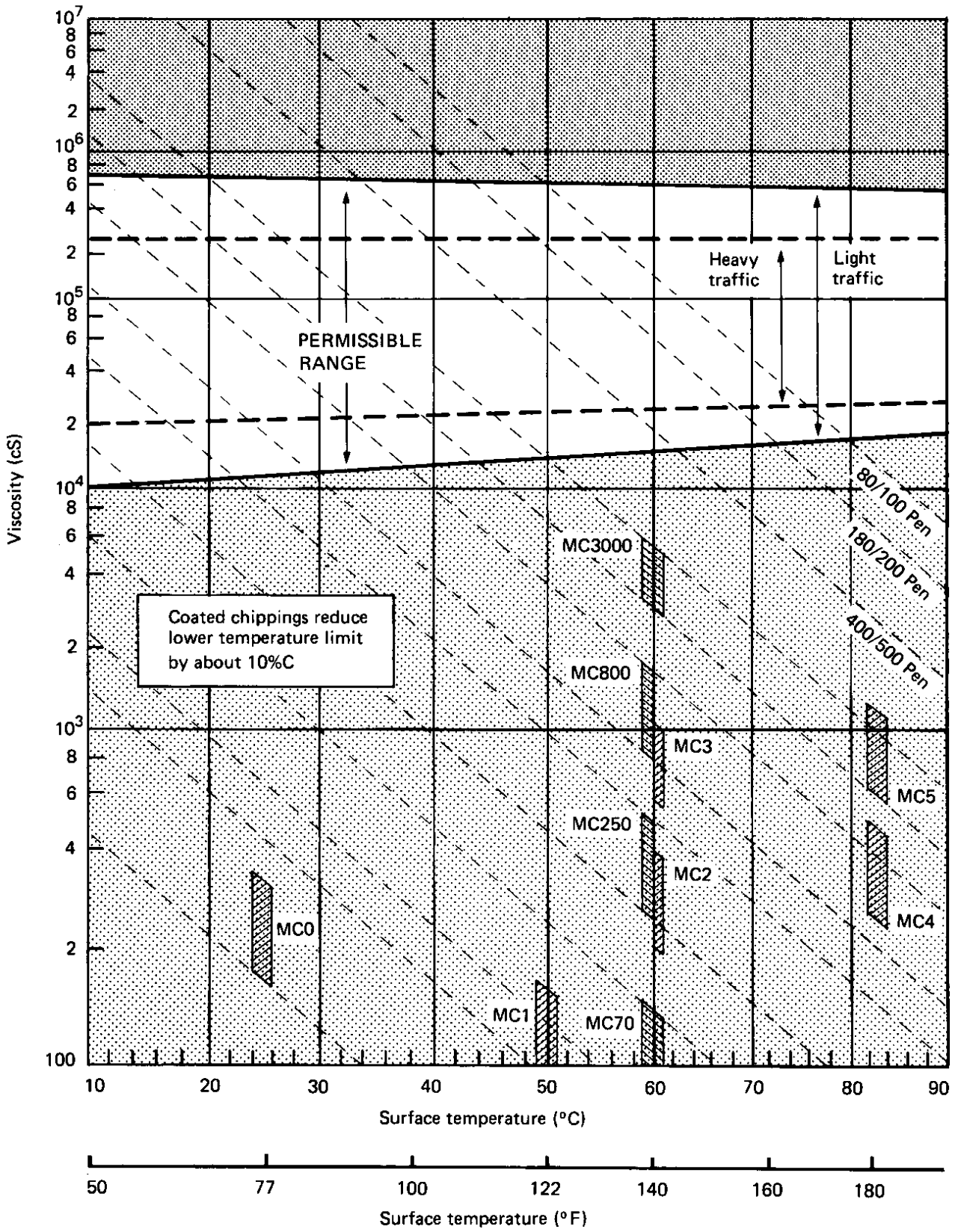
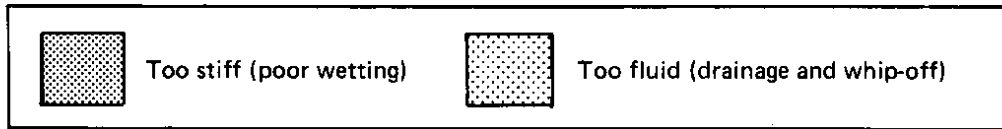

Fig.15 Surface temperature/choice of binder for surface dressing

dressing unit. It is more likely that a mobile unit, comprising the specialised machines and operators, will move from district to district in accordance with a centrally-planned schedule, with non-specialised plant and labour provided by the district in which the unit is working. However, a large part of the work involved in organising and carrying out the surface dressing operation will fall to the District Engineer. The operation of a mechanised surface dressing unit will probably represent the largest single item of road maintenance expenditure and should receive corresponding attention.

A typical surface dressing unit might comprise:

- |           |  |
|-----------|--|
| 1         | bitumen distributor (capacity 5000-8000 litres) with pressurised spray bar and oil-fired heaters |
| 1 or 2    | bitumen preheaters, oil-fired  |
| 8 or more | tipper lorries (supplied by District)  |
| 1 or 2    | chipping spreaders, if lorries are not fitted with spreaders                                     |
| 2         | rubber-tyred rollers   |
| 1         | loading shovel (unless hand loading is used).  |

In determining the make-up of the surface dressing unit it is important to keep a balance between the various items of equipment so that each is utilised to the maximum possible extent. A common fault is that there are too few lorries hauling chippings to keep up with the output of the bitumen distributor. Spraying must stop when no chippings are available for spreading.

Such a unit is potentially capable of single-coat application at rates of up to two kilometres of 2-lane road per day, using some 20,000 litres of bitumen and 200 tonnes of chippings. In practice progress would fall short of this as a consequence of imbalances in equipment, interference by traffic and non-productive time, but the rate of use of materials will still be very high and it is important to ensure that stockpiles are adequate both in extent and location.

## 7.5.4 Application

**7.5.4.1 Preparation of the surface** A surface dressing does not contribute directly to the strength of a road pavement, neither does it improve the riding quality of the existing surface. Therefore it is essential that the underlying material has sufficient strength to withstand the expected traffic loading and is also within the tolerance required for the level of the final running surface.

Any area of the road showing signs of structural weakness should be strengthened and any depressions in the

surface should be filled. Patching should be done well in advance of the surface dressing. For best results, this should be completed during the previous season to ensure that as uniform a texture as possible is available for the subsequent dressing.

It is important that the surface to be treated is clean. Dust and loose aggregate must be swept from the surface so that the binder film can adhere easily.

**7.5.4.2 Application of binder** The final quality of the surface dressing will depend largely on the efficiency of the method of application of the binder, which must be applied uniformly over the road surface. The mechanised bitumen distributor must therefore be fitted with means of controlling the rate of spread of binder longitudinally on the road. In addition, the transverse rate of application across the spray bar should be checked at least once a year in the depot.

Because the distributor is mounted on springs, the spray bar will tend to rise as the load of bitumen in the tank decreases. The correct spray pattern is dependent on the spray bar being kept at the correct height above the road surface and the spray bar must therefore be adjustable in height, under the control of the operator.

The amount of binder actually sprayed for any single run of the distributor must be within plus or minus 10 per cent of the amount calculated by multiplying the area sprayed by the specified rate. In addition to checking the average rate of spread over a substantial area of road by means of readings from the dipstick fitted to the distributor, the actual rate of spread on the road should be determined by means of a tray test as described in Appendix A.

**7.5.4.3 Spraying temperatures** Thermometers must be fitted to the bitumen distributor to measure the temperature of the binder delivered to the spray bar. The spraying temperature for any given grade of bitumen will be related to the design of the spray bar nozzles. It is good practice for a thermometer also to be fitted to the spray bar as inaccurate readings are likely to occur when thermometers within the tank become exposed as the level of binder falls.

The application temperatures for different grades of bitumen are given in Table 12 for each type of jet. Whirling spray jets atomise the hot binder and expel it as a finely divided spray in the shape of a hollow cone. A hood is required to eliminate wind effects. No special setting is required for these jets and the transverse distribution is fairly insensitive to the height of the bar above the road. An unexpected characteristic of these jets is that the rate of spread is increased as the temperature of the binder falls. Slotted jets expel

the hot binder in a thin fan-shaped film and consequently a hood is not required over the bar to protect it from wind. Slotted jets need to be set with the slots at an

**TABLE 12**  
**SPRAYING TEMPERATURES**

	Spraying temperature	
	Whirling spray jets °C	Slot jets °C
<b>Cutback grades</b>		
MC30	50-60	40-50
RC/MC70	65-80	55-70
RC/MC250	95-115	80-90
RC/MC800	115-135	105-115
RC/MC3000	135-155	120-130
<b>Penetration grades</b>		
400/500	160-170	140-150
280/320	165-175	150-160
180/200	170-190	155-165
80/100	180-200	165-175

angle to the horizontal of 15 to 30° so as to permit overlap of adjacent fan patterns. The slots in these jets are not easily blocked and have a fairly high rate of delivery thus the road speed of the machine when spraying is higher than that of a machine fitted with atomising, whirling spray jets.

Because of the inflammable nature of the solvent used in RC-type cutbacks, application temperatures for RC grades should be restricted to the lower parts of the ranges given in Table 12. No smoking or naked flames should be allowed when heating, pumping or spraying any cutbacks. Fire extinguishers should always be readily at hand.

**7.5.4.4 Jointing strips** It is most important to ensure that the thickness of the binder film is not reduced at longitudinal joints. There must be a clear understanding of the jointing technique appropriate to the type of distributor used.

For example, on some machines the intensity of application falls away towards the edges of the strip being sprayed. Adjacent strips should then be overlapped sufficiently to give the required uniformity of spread. This means that the first strip laid must be left uncovered by chippings for a width of several centimetres along the edge to be overlapped.

Other types of machine are designed to apply the full thickness of the binder film to the extreme edge of the strip. With these, great care must be taken to make

a good butt joint as an inaccuracy will lead to chippings not adhering.

A good clean transverse joint may be obtained by the use of a strip of building paper spread across the road on which to start and stop spraying.

**7.5.4.5 Application of chippings** Chippings should be applied uniformly over the freshly sprayed binder film by a mechanical spreader which should follow closely behind the sprayer. Greater uniformity of spread will be achieved with spreaders fitted with metering devices. Any thinly chipped areas found after the passage of a mechanical spreader should be chipped over by hand to obtain shoulder-to-shoulder cover. Any surplus chippings accidentally spilled on to the road surface should be removed.

**7.5.4.6 Rolling** Rubber tyred rollers are strongly recommended for rolling surface dressings. Rolling should start immediately after the chippings have been spread. The faces of the chippings in contact with the binders should be pressed into it, so that maximum adhesion occurs and slow-moving rubber tyres are ideal for this purpose. Steel-tyred rollers tend to crush chippings and to bridge local depressions. If steel rollers have to be used, they should be the lightest available and in no case should their weight exceed 8 tonnes.

**7.5.4.7 Aftercare and opening to traffic** Slow moving traffic can help to roll and align the chippings immediately after surface dressing, but vehicle speeds must be restricted to 30 km/h or less until there is sufficient adhesion to ensure that the chippings will not be plucked from the surface. This period of time will vary from a few hours to a day or more, depending on the climatic conditions and the type of binder employed. Excess chippings should be swept up and taken away before opening the road to unrestricted traffic. Signs may be used to warn of possible damage to windscreens.

## 7.5.4 Control

The success of any surface dressing depends to a large extent on the control of all aspects of the design, application and quality of materials. Table 13 is a checklist of the items that require checking in chronological order. This should be read in conjunction with Appendix A.

## 7.6 MANUAL SURFACE DRESSING

### 7.6.1 Applicability

Labour-based techniques for surface dressing may be

**TABLE 13**  
**CONTROL OF SURFACE DRESSING**

Stage when action should be taken	Action Required
1. Before start of job	<ul style="list-style-type: none"> <li>(i) Check that any pot-holes or edge-failures have been repaired.</li> <li>(ii) Check grading, shape and (if necessary) the resistance to polishing of aggregate.</li> <li>(iii) Ensure that chippings are not dusty or dirty.</li> <li>(iv) Check that binder is of correct type and viscosity.</li> <li>(v) Check availability and condition of plant.</li> <li>(vi) Ensure that traffic control measures are adequate.</li> </ul>
2. Before starting daily work	<ul style="list-style-type: none"> <li>(i) Ensure that the surface to be dressed has been adequately swept and cleaned.</li> <li>(ii) Check binder temperature.</li> <li>(iii) Test spray bar jets.</li> </ul>
3. During work	<ul style="list-style-type: none"> <li>(i) Check rates of spread of binder.</li> <li>(ii) Check that chipping spreading follows closely behind binder distributor and that coverage is correct.</li> <li>(iii) Check that rollers follow immediately after the spreading of chippings.</li> <li>(iv) Check binder temperature at intervals.</li> </ul>
3. After surface dressing	<ul style="list-style-type: none"> <li>(i) Limit traffic speed when road is first opened to traffic.</li> <li>(ii) Remove surplus chippings.</li> </ul>

used on small or remote projects, where the use of plant is too expensive or impracticable. The design principles and standards described in the preceding section relating to mechanical methods apply generally to labour-based work. The following paragraphs describe differences where these are justified, as well as outlining some aspects of manual techniques.

### 7.6.2 Chippings

Chippings for surface dressing will normally be smaller than 20 mm nominal size. Production of these relatively small sizes by hand-breaking is uneconomic even at low

wage rates and is not recommended. Hand-screening of river gravel, however, may be worth considering provided that the product complies with the requirements noted in Appendix A. Notes on hand-screening are given in a separate document (Robinson, 1979).

### 7.6.3 Binder

For small-scale work it may be more convenient to use bitumen-emulsion, applied at the ambient temperature, rather than cut-back or penetration grade which require pre-heating. Cationic emulsions are now probably more commonly used than anionics as they are claimed to be more effective in depositing a binder film on to acidic aggregates. However, as with anionic emulsions, the principal break mechanism is the evaporation of water. Disadvantages common to both types are:

- (i) Poor adhesion to dry or dusty surfaces. This may be overcome by slightly dampening the surface before spraying.
- (ii) Low effective bitumen content (usually not more than 60%), which must be allowed for when calculating rates of application. Emulsions containing up to 70 per cent bitumen have been developed, but have to be heated (to 70-80°C) before spraying, thus losing the advantage of use with unheated equipment.
- (iii) Low viscosity emulsions tend to drain from the crown of the road before the break occurs; cover aggregate is therefore poorly held at the crown, while excess binder accumulates at the edges.
- (iv) Some emulsions tend to coagulate if stored or transported in unsuitable conditions. If emulsion has to be stored for long periods, the drums should be turned over occasionally.

### 7.6.4 Application of binder

Bitumen (cut-back, penetration grade or emulsion) may be applied manually using hand-operated sprayers or by means of watering-cans. The choice of binder type will need to be related at least partly to the application equipment available. In either case, the road surface should be marked out in a rectangular grid such that the area to be covered by each full container (drum or can) is defined. This may be done by placing stones (about fist-size) at the corners of the area to be covered.

Provided that the work is set out in this way and the bitumen applied systematically, it should be possible to get acceptably uniform rates of application. It will be necessary to supervise the work carefully and to instruct operators in detail in the methods to be used. Uneven distribution of bitumen is a common fault when bitumen is applied by hand-lances.



Bitumen for labour-based surface dressing work should be brought to the site in drums and distributed along the work in accordance with the requirements for rate of spread.

Typical productivities for hand-spraying emulsion are 600-1000 litres per day for a unit of three men with one sprayer.

### 7.6.5 Application of chippings

Chippings should be delivered to the site in dumps at intervals of about 400 metres, from where they are taken to the work in wheelbarrows, with an average haul of 100 metres. The chippings are usually spread by a swinging movement with the shovel and this operation also requires close supervision if full coverage is to be achieved. It is necessary to apply a greater excess when spreading chippings manually than when mechanised spreaders are used, the excess being recovered by brooming after rolling and trafficking. Productivity for spreading chippings, including haulage from dumps by wheelbarrows, is about one m<sup>3</sup>/man-day.

### 7.6.6 Rolling

There is no practicable alternative to mechanical rolling. The low outputs from labour-based work will result in under-utilisation of self-propelled rollers, and it may be better to consider the use of tractor-drawn rollers. Any roller should preferably be rubber-tyred, as explained previously.

### 7.6.7 Gang size

The following gang sizes have been found to be practicable:

Spraying bitumen 500 m<sup>2</sup>/day - 3 men plus 1 sprayer  
Spreading chippings 500 m<sup>2</sup>/day - 6 men plus 4 wheelbarrows

Loading/unloading drums, cleaning surface and other odd jobs - 7 men

Total - 16 men plus 1 foreman.  
Also required:

- (i) periodic use of truck or tractor/trailer for delivery of chippings
- (ii) tractor-drawn rubber-tyred roller.

## 7.7 SLURRY SEALING

Slurry seals are mixtures of fine aggregates, bitumen emulsions and additional water. When freshly mixed, they have a thick creamy consistency and can be spread to a thickness of 5 to 10 mm.

The principal application of slurry seals is as a maintenance treatment for old bituminous surfaces. Because of their low viscosity, they can readily penetrate surface

voids and cracks and hold together surfaces that are starting to fret or ravel. Costs are higher than for surface dressing, but the resulting layer can improve the riding quality of the road which a surface dressing would not. The higher costs may therefore sometimes be justified, particularly for badly cracked or lean bituminous surfacings. However, a slurry seal will not have such good surface texture as a surface dressing and may therefore be slippery in wet weather.

Both anionic and cationic emulsions may be used, but cationic emulsion is normally used in slurries containing acidic aggregates. Anionic slurries may be premixed in a static mixing plant but, because emulsions in cationic slurries break relatively quickly, these have to be prepared in a purpose-built mixing and laying machine. A contractor usually supplies this equipment, its operators and the bitumen binder; the maintenance organisation will usually supply the aggregate, water and the labour force. The laying technique can range from simple 'squeegees' to modern mixer-spreader units.

The following specification is reproduced by permission of Colas (East Africa) Ltd.

### Aggregate Gradations (all percent cumulative, passing)

Sieve	Fine Seal	General Seal	Coarse Surface
10mm	100	100	100
6.3 mm	100	100	-
5.0 mm	100	85-100	70-90
2.36 mm	100	65-90	45-70
1.18 mm	65-90	45-70	28-50
600 µm	40-60	30-50	19-34
300 µm	25-42	18-30	15-25
150 µm	15-30	10-21	7-18
75 µm	10-20	5-15	5-15

### Slurry Composition

	Per m <sup>3</sup>	Percent by mass
Aggregate	1m <sup>3</sup>	81-83
Cement (catalyst)	15kg	1

Terolas A3 bitumen emulsion *	280-330 litres	16-18
-------------------------------	----------------	-------

Water As required

\* Type A3 is a slow setting anionic emulsion, 55 per cent bitumen (minimum)

### Coverage

	m <sup>2</sup> /m <sup>3</sup>
Old surfaces	130-250
New surfaces:	
On 20mm aggregate	130 – 170
On 14mm aggregate	170 – 240
On 10mm aggregate	180 – 250
On primed base	150 – 180 (in 2 layers)

## 8. REFERENCES

AVELING-BARFORD, undated. Grading illustrated. *Technical Publication TP 549*. Grantham: Aveling-Barford Ltd.

BSI, 1971. Specification for single-sized road-stone and chippings. *BS63: 1971 (Part 2)*. London: British Standards Institution.

BSI, 1975. Methods for sampling and testing of mineral aggregates, sands and fillers. *BS812: 1975 (Parts 1, 2 and 3)*. London: British Standards Institution.

ROBINSON, R, 1979. Some manual methods of screening aggregates for labour-intensive road construction. *TRRL Supplementary Report 503*. Crowthorne: Transport and Road Research Laboratory.

TRRL OVERSEAS UNIT, 1981. Maintenance management for District Engineers. *Overseas Road Note 1*. Crowthorne: Transport and Road Research Laboratory.

TRRL OVERSEAS UNIT, 1982. A guide to surface dressing in tropical and sub-tropical countries. *Overseas Road Note 3*. Crowthorne: Transport and Road Research Laboratory.

## APPENDIX A

### ADDITIONAL NOTES ON SURFACE DRESSING

#### A.1 CHIPPINGS

##### A.1.1 Size

The chippings for a surface dressing should be of single-sized crushed rock, roughly cubical in shape and clean and free from dust. The nominal sizes used may vary between 6 mm to 20 mm according to the local requirements. The chippings should comply with *BS63: Specification for single sized roadstone and chippings* (BSI, 1971). It is most important that the chippings should be single sized. Graded chippings make design and construction much more difficult and their use, without the much closer control which is required, will lead to loss of the larger sizes of chipping and to fattening-up of the surface dressing. Single sized aggregate may be more expensive to produce than graded aggregates, but their higher cost can be offset by better performance. The remaining sizes of stone can be absorbed into other sectors of the road construction programme.

Recommendations for the grading of surface dressing aggregate are given in Table A1.

The use of rounded-gravel aggregates should, if possible, be avoided because it is difficult for the binder film to hold them in place and because of their poor surface friction properties. If their use cannot be avoided, adjustments must be made to the rate of spread of bitumen. The rounded aggregates do not interlock and more bitumen is required to hold the particles firmly to the road surface than is required for cubical aggregates.

##### A.1.2 Average least dimension

Once the surface dressing is laid, the traffic will orientate the chipping to lie as flat as possible with the least dimension vertical. Therefore the Average Least Dimension (ALD) is the measurement which best classifies the chippings and gives a guide to the required rate of spread of bitumen and the rate of spread of chippings. Two methods for determining the Average Least Dimension of the chippings are given below:-

###### Method 1

The ALD of chippings may be determined by taking a representative sample, say 200 chippings, and measuring the least dimension of each chipping with a pair of calipers. The average of a series of such measurements is then the ALD of the chippings.

###### Method 2

A sieve analysis is first carried out on a surface-dry sample of the chippings and the results plotted on a

TABLE A1  
GRADING AND SHAPE OF CHIPPINGS

Nominal size	Specified size			Oversize		Undersize							Specified size and oversize
	2	3	4	5	6	7	8	9	10	11	12	13	
	Passing BS test sieve (BSI, 1969)	Retained on BS sieve	Minimum proportion of specified	All to pass BS test sieve	Maximum retained on BS test sieve quoted in column 2	Passing BS test sieve	Maximum proportion of undersize	Passing BS test sieve	Maximum fines	Passing BS test sieve	Maximum dust	Maximum permissible flakiness index	
mm	mm	mm	%	mm	%	mm	%	mm	%	mm	%	mm	
50	50.0	37.5	70	63.0	15	28.0	5	2.36	2	75	1.5	40	
37.5	37.5	28.0	60	50.0	15	20.0	5	2.36	2	75	1.5	40	
28	28.0	20.0	60	37.5	15	14.0	7	2.36	2	75	1.5	35	
20	20.0	14.0	60	28.0	15	10.0	7	2.36	2	75	1.5	35	
14	14.0	10.0	60	20.0	15	6.30	7	2.36	2	75	1.5	35	
10	10.0	6.30	65	14.0	15	5.00	10	2.36	2	75	1.5	35	
6	6.30	3.35	65	10.0	15	2.36	10	μm 600	2	75	1.5	—	
3	3.35	1.70	65	6.30	15	1.18	10	600	2	75	1.5	—	

This table does not include requirements for the immediate undersize material, but this fraction is controlled by the remaining requirements of this standard.

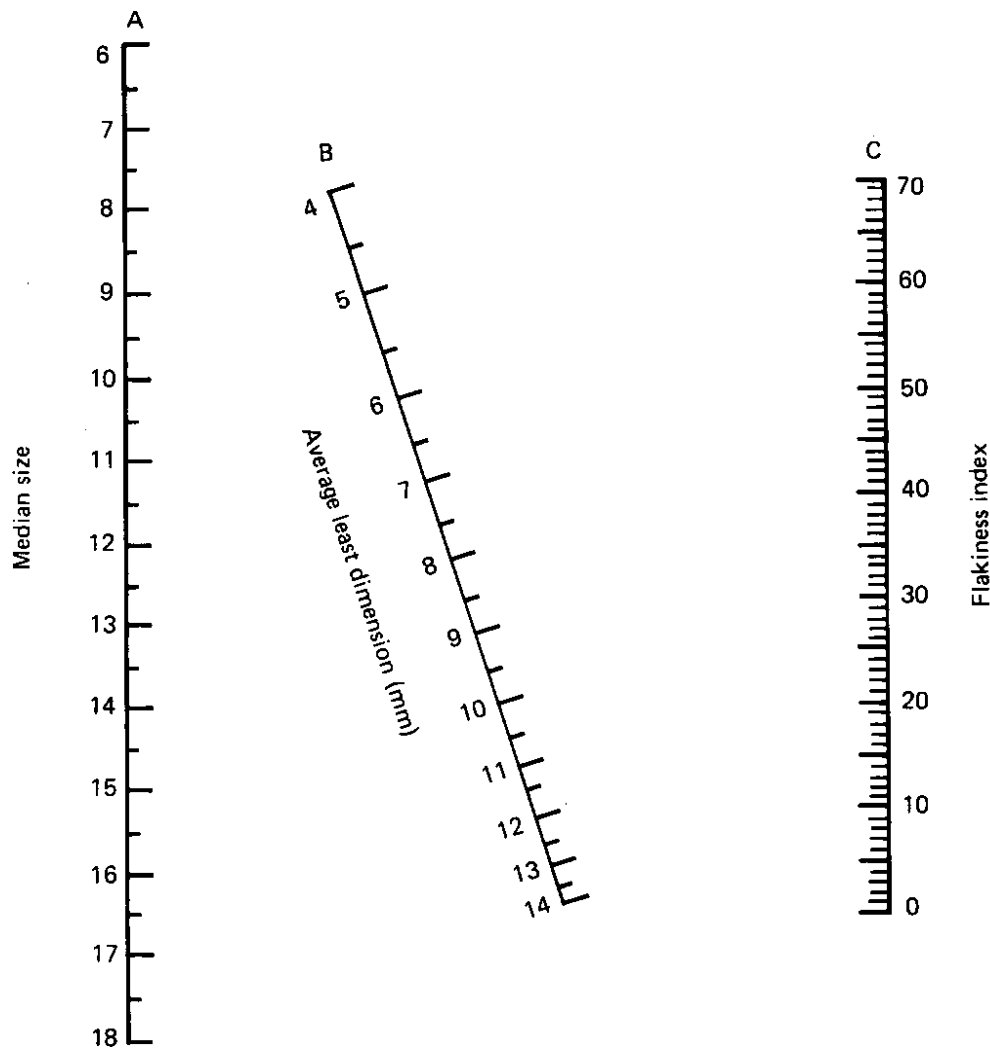

Fig. A1 Average least dimension chart

large scale grading curve. The median size of chipping is then determined as that theoretical sieve size through which 50 per cent of the material will pass. The flakiness index is determined as in Section A.1.3. Then using Figure A1 the median size is marked on scale A and flakiness index on scale C. A straight line is drawn between the two marks and the Average Least Dimension read off on scale B.

### A.1.3 Flakiness

The flakiness index of chippings should not exceed 35. The method for determining flakiness index is given below. The chippings should also satisfy at least one of the following strength criteria:-

Aggregate crushing value - less than 25 (Values up to 35 may be permitted for lightly trafficked roads)

Aggregate abrasion value - less than 12

Ten per cent fines value - not less than 8

Aggregate impact value - less than 30

Descriptions of these tests are given in *BS812. Methods for sampling and testing mineral aggregates, sands and fillers Part 3: Mechanical properties* (BSI, 1975).

The flakiness index of an aggregate is the percentage by weight of particles in it whose least dimension (thickness) is less than three fifths of the nominal size. The test is not applicable to material passing a 6.30 mm sieve.

Apparatus consists of:-

- (i) A metal thickness gauge of the pattern shown in Figure A2. The width of the slot used in the gauge shall be the dimension specified in the 'thickness gauge' column of Table A2 for the appropriate fractions.
- (ii) BS test sieves as shown in Table A2 (BSI, 1969).
- (iii) A balance accurate to 0.5 per cent of the weight of the test sample.

1. Sample quantities are given in Table A2. Allowance should be made for the later rejection of particles retained on 63 mm BS

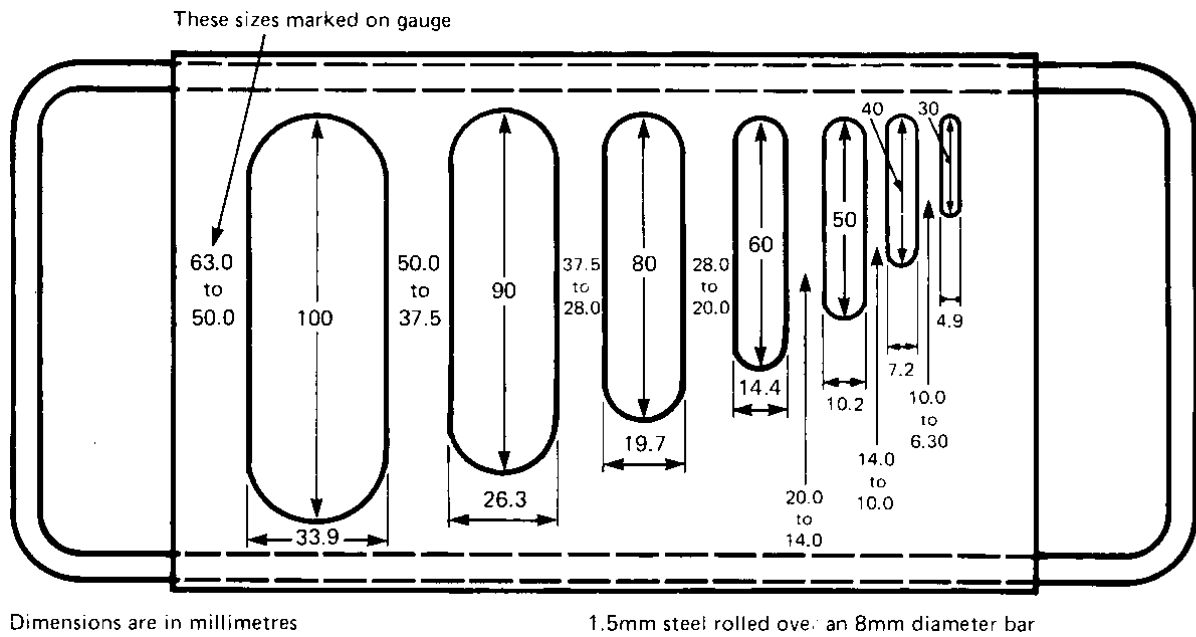

**Fig.A2 Thickness gauge**

**TABLE A2**

**DIMENSIONS OF THICKNESS GAUGES**

Aggregate size-fraction		Thickness gauge Width of slot	Minimum mass for subdivision
BS test sieve nominal aperture size			
100% passing	100% retained		
mm	mm	mm	kg
63.0	50.0	$33.9 \pm 0.3$	50
50.0	37.5	$26.3 \pm 0.3$	35
37.5	28.0	$19.7 \pm 0.3$	15
28.0	20.0	$14.4 \pm 0.15$	5
20.0	14.0	$10.2 \pm 0.15$	2
14.0	10.0	$7.2 \pm 0.1$	1
10.0	6.30	$4.9 \pm 0.1$	0.5

- test sieve and passing 6.30 mm BS test sieve. The test sample shall be obtained from the laboratory sample by quartering, and dried.
2. The sample shall be weighed and separated into the appropriate size fractions from Table A2, columns 1 and 2, by sieving, rejecting material retained on a 63 mm sieve or passing a 6.3 mm sieve. Record the sum of all fractions  $M_1$ , discard those which are 5 per cent or less of  $M_1$  and record the remainder as  $M_2$ .
3. Each appropriate fraction shall be gauged in turn for thickness on the thickness gauge.
4. The total amount  $M_3$  passing the thickness gauge shall be weighed to an accuracy of at least 0.5 per cent of the weight of the test sample.
5. The flakiness index is the total weight  $M_3$  of the material passing the various thickness gauges, expressed as a percentage of the total weight  $M_2$  of the sample gauged to the nearest whole number, and shall be reported together with the sieve analysis.

$$\text{Flakiness Index} = \frac{M_3 \times 100}{M_2}$$

### A.1.4 Adhesion and pre-treatment

The most critical period for a surface dressing occurs immediately after the chippings have been applied. At this stage the chippings have not formed an interlocking mosaic and they are held mainly by adhesion forces in the binder film. This adhesion takes time to develop and is completely stopped if the chippings remain wet.

Adhesion is very slow to develop if the chippings are dusty. However in hot climates the chippings may be washed with fresh or salt water just prior to spreading since the chippings dry out in a few minutes after they are spread on the road and the development of adhesion is not significantly delayed.

If adhesion problems are experienced it may be useful to treat the chippings with a light spray of diesel oil or kerosene prior to spreading. Enough should be added to render the surface of the chippings slightly damp.

### A.1.5 Stockpiling

Chippings should be stored in stockpiles which are large enough to supply four to five days work without hauls exceeding 15 kilometres.

Stockpiles will typically be about 2000 tonnes and will require an area of about 1000 m<sup>2</sup> if formed by tipping from lorries. If suitably located, these areas will be re-used at intervals of three to five years, and some permanence in their construction will be justified by a reduction in wastage of chippings.

They may be surfaced, either with a two-coat surface dressing, bricks or concrete, with a compacted gravel base in each case. A concrete or brick wall about one metre high on three sides will define the stockpile, avoid contamination and simplify measurement.

## A.2 BINDER

### A.2.1 Grade

The performance and qualities required of a surface dressing binder makes the choice of the binder critical.

The binder must:-

- (i) be sprayable at a reasonable temperature,
- (ii) 'wet' the surface of the road and remain in a continuous film waterproofing the road structure,
- (iii) not run off a steep gradient or cambered road or form pools of binder,
- (iv) 'wet' and adhere to the stone chippings at road temperature,
- (v) be strong enough to resist the traffic force and

retain the chippings even at the highest ambient temperatures,

- (vi) be flexible at the lowest ambient temperature, neither cracking and allowing water to enter nor brittle thus allowing the chippings to break free,
- (vii) resist excessive weathering and hardening once the initial hardening has taken place.

Surface dressing work will normally be carried out with cut-back or penetration-grade bitumens. Cut-back bitumens are likely to be of the high-viscosity, medium-curing type. The advantage of these binders is that the cutting agent (normally kerosene) lowers the viscosity sufficiently to obtain good wetting of the chippings by the binder. Also the small quantity of cutting agent present results in a reasonably rapid set to hold the chippings after initial adhesion has been achieved. Penetration-grade bitumens may be used in the drier, hotter regions, depending upon actual road temperatures at the time of working.

With mechanised methods, the rate of consumption of bitumen is high and it is desirable that it is supplied in bulk rather than in drums, with their associated problems of handling and leakage. It is more economic to transport bitumen in bulk than in drums and the pre-heaters can, if large enough, act as holding tanks and ensure that occasional interruptions to the supply do not disrupt the whole operation.

It is not usually necessary to test the grade of the bitumen on site, reliance being placed on the supplier's certificate.

### A.2.2 Viscosity

Surface dressing binders should have a viscosity of between 10<sup>4</sup> and 5 x 10<sup>5</sup> centistokes at the prevailing road temperature. At higher viscosities, stone will not be wetted by the binder and will be lost by whip-off; at lower viscosities wetting will occur but the binder will be too fluid to hold the stone. Figure 15 shows the relationship between binder viscosity and road temperature for a wide range of binders and provides a means of selecting a suitable binder for use with a particular road surface temperature. Daytime road surface temperatures in dry weather in the tropics are likely to range from 30°C to 70°C according to region and season. This suggests that the most suitable binders for surface dressing will be between MC 3000 and 80/100 pen bitumen. The use of a more viscous bitumen than 80/100 pen is not recommended. Occasionally chippings have to be spread manually instead of by mechanical gritters. In such cases it may be advisable to use a slightly less viscous binder than would otherwise have been required. (See also Section 7.6 on manual surface dressing).

It is unlikely that the complete range of possible binders will be available to the engineer and therefore for practical reasons it will probably be necessary to select perhaps two binders for general surface dressing use. In this case MC 3000 and 180/200 pen are likely to be the most suitable: MC 3000 for roads with prevailing surface temperatures less than 45°C and 180/200 pen when prevailing surface temperatures are 45°C and above.

### **A.2.3 Measuring the rate of spread of the binder**

**A.2.3.1 Average rate** There are two methods of measuring the average rate of spread of the binder. In the first the volume of binder sprayed is calculated from weighbridge records and this is divided by the measured area covered in a day. Although this is useful in checking quantities for payment, it does not reveal differences in rates of spread along the road and is therefore of limited value.

A better method, which should be used on every site, is to measure the average rate over an area of 500 - 800 square metres. If the distributor is fitted with an accurate dipstick, this method can be of considerable value even though it does not give a measure of maximum variation. To make the test, the distributor is placed on a level stretch of road and the position of the wheels are marked. Dipstick readings are taken, repeating the dips until consistent readings are obtained. Binder is sprayed by the normal technique until about 10 per cent of the total volume in the tank has been used. Dipstick readings are taken with the distributor in the same position as before.

The area covered is then measured accurately and the average rate of spread calculated after allowance has been made for any variation in the intensity of application at the longitudinal joint (see jointing of strips, Section 7.5.4.4).

**A.2.3.2 Longitudinal variation** Longitudinal variation in the rate of spread of the binder can be checked with a tray test. In this test, light metal trays about 200 mm square by 5 mm deep, and numbered, are placed at intervals along the road in the path of the binder distributor. After the distributor has passed, the trays are removed, wrapped in weighed sheets of paper and taken away to be weighed; the rate of spread can then be calculated for each point on the road. A balance accurate to 0.1 gramme installed in a car, van or mobile laboratory permits the results from five trays to be obtained within 10 minutes. The spacing and number of trays used can be varied to suit the circumstances of the particular investigation, but at least five

trays should be used. When using this test, care must be taken to raise the protective hood on the distributor, if fitted, so that it does not touch the trays, but not so much as to let any wind disturb the spray.

The tray test only gives an approximation to the average rate of spread. If it is to be used, it must be remembered that the maximum variation shown by individual trays will be greater than that of groups of trays. The mean result from three or more trays, spaced at intervals of not less than 10 metres, should fall within 10 per cent of specification.

## **A.3 REFERENCES**

BSI, 1969. Specification for test sieves. *BS410: 1969*. London: British Standards Institution.

BSI, 1971. Specification for single sized road-stone and chippings. *BS63: 1971 (Part 2)*. London: British Standards Institution.

BSI, 1975. Methods for sampling and testing mineral aggregates, sands and fillers. *BS812: 1975 (Parts 1, 2 and 3)*. London: British Standards Institution.

## NOTES



ISSN 0951 - 8987

**Maintenance techniques for district engineers    ORN 2**

OS-E