



DFID Department for
International
Development

OVERSEAS ROAD NOTE 18



***A guide to the pavement evaluation
and maintenance of bitumen-surfaced
roads in tropical and sub-tropical
countries***



Overseas Centre
Transport Research Laboratory, Crowthorne, Berkshire, United Kingdom



Transport Research Laboratory
Old Wokingham Road
Crowthorne, Berkshire, RG45 6AU

DFID Department for
International
Development

Department for International Development
94 Victoria Street
London, SW1E 5JL

Overseas Road Note 18

**A guide to the pavement evaluation and
maintenance of bitumen-surfaced roads in
tropical and sub-tropical countries**

Subsector: Transport

Theme: T2

Project title: Rehabilitation of roads with bituminous surfacings

Project reference: R 6023

This document is an output from a project funded by the UK Department for International Development (DFID) for the benefit of developing countries. The views expressed are not necessarily those of the DFID.

TRL is committed to optimising energy efficiency, reducing waste and promoting recycling and re-use. In support of these environmental goals, this report has been printed on recycled paper, comprising 100% post-consumer waste, manufactured using a TCF (totally chlorine free) process.

Transport Research Foundation Group of Companies

Transport Research Foundation (a company limited by guarantee) trading as Transport Research Laboratory. Registered in England, Number 3011746.

TRL Limited. Registered in England, Number 3142272.
Registered Offices. Old Wokingham Road, Crowthorne, Berkshire, RG45 6AU.

ACKNOWLEDGEMENTS

This Overseas Road Note was produced in the Civil Engineering Resource Centre of the Transport Research Laboratory (Programme Director Mr T Toole) on behalf of the Department for International Development. The research has been carried out with the active collaboration of highway authorities in many countries and their help and cooperation has been essential to the success of the project. The TRL project team responsible for this Road Note were Mr C R Jones (Project Officer), Dr J Rolt, Mr H R Smith and Mr C Parkman. The helpful comments of Mr P May of May Associates are gratefully acknowledged. Where necessary, use has been made of work published by other research and road authorities.

OVERSEAS ROAD NOTES

Overseas Road Notes are prepared principally for road and transport authorities in countries receiving technical assistance from the British Government. A limited number of copies is available to other organisations and to individuals with an interest in roads overseas, and may be obtained from:

International Development Advisory and Information Unit
Transport Research Laboratory
Crowthorne, Berkshire, RG45 6AU
United Kingdom

Limited extracts from the text may be reproduced provided the source is acknowledged. For more extensive reproduction, please write to the address given above.

CONTENTS

	Page
1 Introduction	1
Scope of this note	1
Project appraisal	1
2 Pavement evaluation and maintenance procedure	1
3 Interpretation of existing data	3
4 Surface condition and roughness surveys	4
Surfacing defects	6
<i>Bleeding and fatting-up</i>	6
<i>Fretting and stripping</i>	6
<i>Loss of stone</i>	6
<i>Surface texture</i>	6
<i>Aggregate polishing</i>	6
Cracking	7
<i>Type</i>	8
<i>Intensity</i>	8
<i>Position</i>	9
<i>Width</i>	9
<i>Extent</i>	9
Deformation	9
<i>Rutting</i>	9
<i>Depressions</i>	11
<i>Corrugations</i>	11
Other types of deterioration	11
<i>Potholes and patching</i>	11
<i>Edge failures and shoulder erosion</i>	12
<i>Deterioration caused by pool-drainage</i>	12
Roughness measurements	12
5 Localised surfacing defects	13
6 Performance charts	14
7 Additional tests	17
Deflection tests	17
Dynamic cone penetrometer tests	19
Destructive sampling and material testing	19
Skid resistance tests	20

	Page
8 Identifying the causes of pavement deterioration	21
Rutting without shoving	21
Rutting with shoving	21
Wheelpath cracking - asphalt surfacing	21
Wheelpath cracking - thin bituminous seal	30
Non-wheelpath cracking - asphalt surfacing	30
Longitudinal cracking	30
Transverse cracking	30
Block cracking	31
Crocodile cracking	31
Non-wheelpath cracking - thin bituminous seal	31
9 Maintenance and rehabilitation	33
Analytical approach	33
Structural approach	34
Deflection approach	34
Maintenance options	35
Reflection cracking	36
10 References	41
11 Applicable standards	43
Appendix A: Detailed surface condition survey	44
Appendix B: Road roughness measurements	45
Appendix C: Deflection beam measurements	50
Appendix D: Deflection beam survey procedure	53
Appendix E: Falling Weight Deflectometer (FWD) test procedure	54
Appendix F: TRL Dynamic Cone Penetrometer (DCP) test procedure	56
Appendix G: Test pit procedure	61
Appendix H: Sand patch test	65
Appendix I: The portable skid-resistance tester	66

1 Introduction

Scope of this note

1.1 This Road Note gives guidance on road pavement evaluation procedures suitable for bituminous-surfaced roads in tropical and sub-tropical climates and reviews alternative methods of maintenance and repair. It is intended primarily for highway engineers who are responsible for maintaining roads in tropical and sub-tropical environments but the techniques and principles on which it is based are equally applicable in other environments.

1.2 Paved roads in tropical and sub-tropical climates often deteriorate in different ways to those in the more temperate regions of the world, because of the harsh climatic conditions and often a lack of good road pavement materials. In addition, roads in many countries often suffer from accelerated failures caused by variable quality control during construction, high axle loads and inadequate funding for maintenance.

1.3 This Road Note describes methods of pavement evaluation designed to establish the nature, severity and extent of the road deterioration. It gives guidance on the use of non-destructive and destructive pavement tests and describes how the results of these tests can be interpreted, both to identify the causes of the deterioration and to assess the strength of the existing road. It also reviews alternative rehabilitation design procedures and comments on their limitations and advantages.

Project appraisal

1.4 The process of road project appraisal is described in detail in Overseas Road Note 5 (TRRL, 1988). It can be summarised in the following stages:

- Road project identification
- Feasibility and preliminary design
- Detailed design
- Implementation
- Evaluation

1.5 During the preliminary design stage, the pavement evaluation study establishes the nature, severity and extent of the road deterioration, the cause of the deterioration and the strength of the existing road pavement. This information, together with the material test results, is used to identify alternative maintenance or rehabilitation strategies which can be considered in the subsequent project appraisal. This appraisal will consider the social impact, environmental impact and economic viability of each alternative. The economic viability is normally assessed using existing road transport investment models such as RTIM3 (TRRL, 1993a) and HDM III (Watanatada et al, 1987) and HDM-4 (to be

released in 1999). During the detailed design stage, the pavement evaluation is based on similar information but the frequency of measurement is increased, to validate the findings of the feasibility study and to optimise the design of each segment of the project road. This Note gives guidance on pavement evaluation procedures which can be used during both the preliminary and detailed design stages of a project to maintain or upgrade an existing road.

2 Pavement evaluation and maintenance procedure

2.1 The process of selecting appropriate methods of maintenance or rehabilitation is shown in Figure 2.1 and can be summarised as follows:

- Collect and interpret existing design, construction and maintenance data.
- Carry out surface condition, roughness and traffic surveys.
- Carry out structural and materials testing.
- Establish the cause of the pavement deterioration.
- Select appropriate method of maintenance or rehabilitation.

2.2 Each road authority will have a different approach to the management of the road network. Some authorities adopt a comprehensive approach with the support of formal road management systems and collect data on a regular basis for planning and programming purposes. The data collected as part of such a system are often sufficient for feasibility studies at project level but are rarely sufficient for detailed design. The procedures described in this Road Note are based on the assumption that very little data are available, however, in situations where this is not so, the recommendations can be easily adapted. For example, the stages prior to the detailed condition survey (Figure 2.1) may be carried out on a regular basis and therefore be completed already. Nevertheless, it is always advisable to verify the accuracy of data supplied from other sources before use.

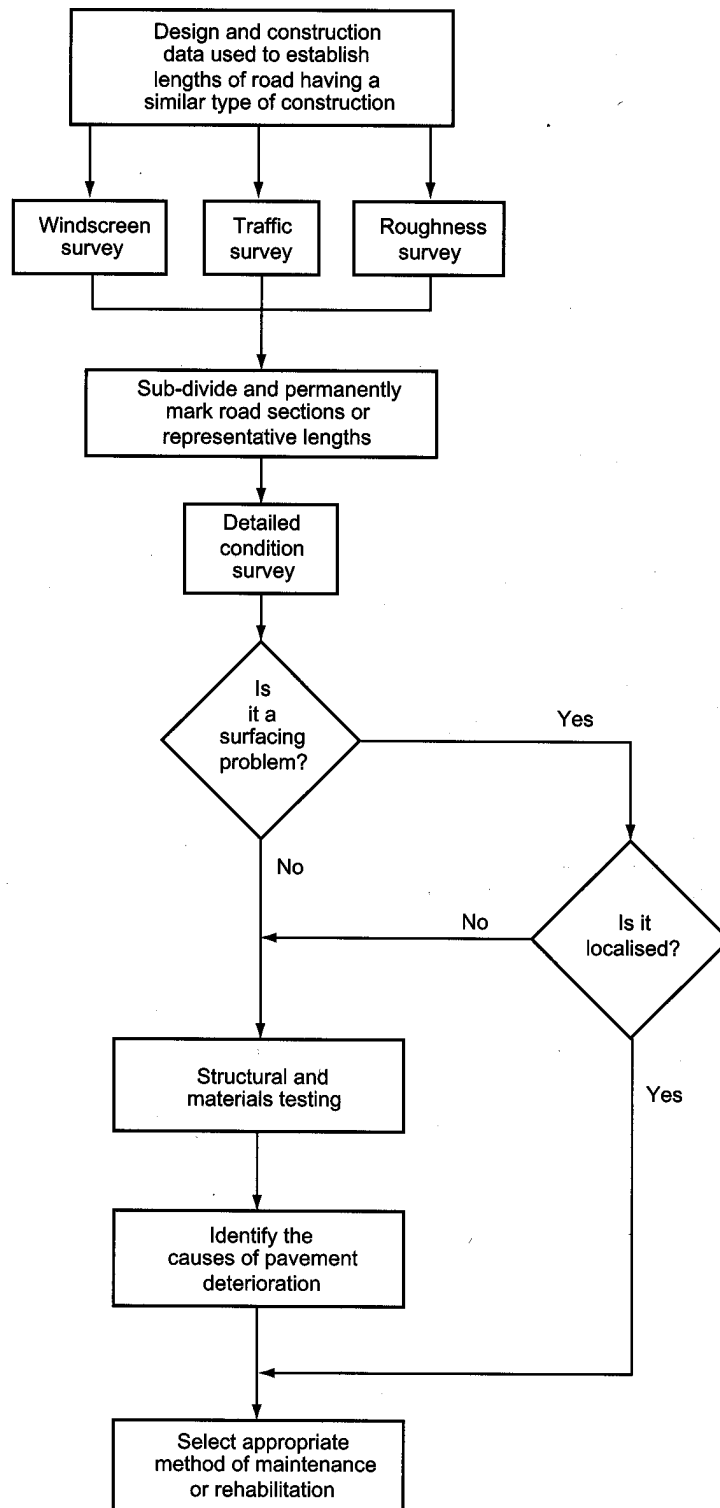

Figure 2.1 Road pavement evaluation and rehabilitation procedure

3 Interpretation of existing data

3.1 Design, construction and maintenance data, if available, can be used to establish the type and approximate thickness of the pavement construction. Using the data, those lengths of road having the same nominal thickness and type of construction are identified. Each length of road is then treated as a separate evaluation exercise.

3.2 The traffic loading (in terms of equivalent 80 kN standard axles (esa)) that the road pavement has carried since its construction should be calculated (TRL, 1993b). Often, historical traffic counts are available but reliable axle load data will not have been collected. If neither classified traffic counts nor axle load data are available then surveys should be carried out as part of the evaluation exercise in order to establish current values. Techniques for carrying out such surveys are described in Road Note 40 (TRRL, 1978). If historical traffic data are available, the total commercial traffic loading that the road has carried since construction can be estimated. If this information is not available then the total traffic loading to date can be estimated using traffic growth rates based on other information. These techniques are described in Overseas Road Note 5.

3.3 It is important that, wherever possible, axle load data should be separated by direction of traffic as any differences in axle loads can be useful in identifying the causes of pavement deterioration. Significant differences can occur on roads that lead to quarries or major ports where, for example, raw materials are being exported or imported.

4 Surface condition and roughness surveys

4.1 After dividing the road into lengths of nominally similar construction, it may be necessary to subdivide it again based upon the current condition of the road. This can be done by carrying out a windscreen survey. The best way to do such a survey is for the survey vehicle to stop at 500 metre or one kilometre intervals to enable the condition of the road pavement to be recorded accurately using a selection of the road pavement deterioration criteria described in paragraphs 4.7-4.27. Note that important aspects of road deterioration may be missed if the vehicle is not stopped and survey staff given the opportunity to inspect the road closely. The roughness of the road should also be measured at this stage in the evaluation (see paras 4.28-4.30). These measurements are necessary for the economic appraisal and are useful in defining sections of road in similar condition. The road can then be subdivided into shorter uniform sections based upon the following:

- time since construction;
- traffic loading;
- type of road deterioration; and
- topography.

4.2 Detailed condition surveys of the sections are then carried out. When the uniform sections are relatively short, the detailed condition survey is best carried out over the entire length of the section. However, where resources are limited then a number of representative one kilometre lengths of road can be used to identify the cause of pavement distress (see para 4.30). The length of road investigated by this method should represent no less than 10 per cent of each section.

4.3 Before the detailed surface condition is carried out, the section or representative one kilometre length is permanently marked into 'blocks' of equal length. For inter-urban roads the maximum block length should be either 50 or 100 metres, however, the length may be reduced to as short as 10 metres if the road is severely distressed.

4.4 During the detailed surface condition survey the nature, extent, severity and position of the following defects is recorded:

- surfacing defects; eg bleeding, fretting, stripping etc.
- cracking
- deformation (excluding rutting)
- patching and potholes
- edge failures

Rutting is recorded once at the beginning of each of the blocks. It is important that rutting is measured at a discrete point as its severity may need to be

compared with other non-destructive tests carried out at the same location (see para 8.5).

4.5 The resources and the equipment required for the detailed condition survey and the operational details are described in Appendix A.

4.6 The recommended form for recording the surface condition data is shown in Figure 4.1. It is designed to be as flexible as possible since the nature of paved road deterioration varies depending on factors such as the type of construction, climate and traffic levels. There are, however, a number of defects that tend to be common to all road pavements and these are described in Table 1. There are three blank areas on the surface condition form which should be used if the other defects, described in Table 2, occur.

Table 1 Terms on the surface condition form

<i>Item</i>	<i>Description</i>
Road No.	The nationally accepted route number
Form No.	Numbers to run consecutively
Date	Day/month/year
Inspector	Name of Inspector
Start	Some countries have established markers for an existing road inventory. In this case they should be used. If not, permanent markers such as junctions should be used.
Direction	The direction towards a permanent feature, preferably a large town.
Road width	The width should be measured and recorded at the beginning of each form.
Surfacing	Type (asphalt/bituminous seal)
Shoulder	Type (gravel/sealed) and width
Chainage	Chainage 0+000 is at the start point. If 50m blocks are used then following chainages will be 0+050, 0+100 ...etc (see para 4.3)
Crack type	Letters L, T, B, C or P (see para 4.14)
Crack intensity	Nos 0-5 (see para 4.15)
Crack position	Letters V, O or CW (see para 4.16)
Crack width	Nos 1-4 (see para 4.17)
Crack extent	Nos 1-3 (see para 4.18)
Rut depth	Max. value recorded in either the verge or offside wheelpath. If shoving (see para 4.22) is occurring the value should be circled.
Aggregate polishing	Letters H, A or S (see para 4.12)
Surface texture	Letters F, M or C (see para 4.11)
Potholes and patching	As defined in para 4.25

Surface condition survey		Road No.	Form No.	Date	Inspector	
Start point	Surfacing					
Start chainage	Road width		Shoulder			
Towards	Cracking	Type				
		Intensity				
		Position				
		Width				
		Extent				
	Rut depth					
	Agg. polishing					
	Surface texture					
	Potholes/Patching					
	Notes:					
Towards	Cracking	Type				
		Intensity				
		Position				
		Width				
		Extent				
	Rut depth					
	Agg. polishing					
	Surface texture					
	Potholes/Patching					
	Notes:					

Figure 4.1 Detailed surface condition form

Table 2 Other defects

<i>Item</i>	<i>Reference</i>
Bleeding/Fatting-up	As defined in para 4.7 Extent as Table 3
Fretting/Stripping	As defined in para 4.9 Extent as Figure 4.2
Loss of stone	As defined in para 4.10 Extent as Table 3
Depressions	As defined in para 4.23 Extent as Table 3
Corrugations	As defined in para 4.24 Extent as Table 3
Edge damage	F or S (see para 4.26) Extent as Table 3

Surfacing defects***Bleeding and fatting-up***

4.7 Bleeding is usually observed first in the wheelpaths and is the result of bitumen being forced to the road surface by the action of traffic. Fatting-up of the surface is a less extreme form of bleeding where the surface becomes very smooth but there is insufficient binder to form a continuous film on the surface.

The following definitions are recommended:

- Bleeding: Continuous film of binder covering the aggregate.
 Fatting-up: Smooth and shiny appearance but aggregate visible.

4.8 Bleeding and fatting-up can often be discontinuous. In asphalt surfacings this can be the result of variations in the mixing process, local over application of tack coat or secondary compaction by traffic. In surface dressings it can be caused by variability in the prepared surface or poor quality control during the spray and chip operation.

Fretting and stripping

4.9 Fretting is the progressive loss of fine aggregate from the road surface and occurs when the small movements of individual particles, under the action of traffic, exceeds the breaking strain of the bitumen. It tends to occur later in the life of the surfacing after the bitumen itself deteriorates with age and usually begins in areas of high traffic stress such as sharp bends. The loss of fine aggregate at the surface results in lack of mechanical interlock which can eventually lead to the loss of coarse aggregate and the formation of potholes. Stripping in asphalt surfacings is the result of the displacement of binder from the surface of the aggregate caused by the combined action of water and traffic. In most cases there is a migration of the binder towards the surface of the road resulting in localised bleeding at the surface and unstable poorly coated aggregate

beneath. These areas then disintegrate under traffic and develop into shallow potholes. The introduction of denser asphalt mixes and the use of cement and hydrated lime as filler has largely reduced the occurrence of stripping in asphalt surfacings.

Although the mechanisms of failure differ, the result of both of these types of deterioration will be a shallow pothole or a series of potholes. Hence the extent of the defect can be recorded as shown in Figure 4.2.

The following definition is recommended:

- Fretting/Stripping: Shallow potholes having a diameter greater than 100mm.

Loss of stone

4.10 The loss of chippings from a surface dressing resulting from poor adhesion between the binder and the aggregate appears early in the life of the surfacing. It starts in the wheelpaths but, with time, the problem may spread across the carriageway making it difficult to differentiate between this type of failure and bleeding. However, it can often be identified by an accumulation of drippings at the edge of the road pavement. The extent of the defect is recorded according to Table 3.

The following definition is recommended:

- Loss of stone: Continuous film of bitumen visible due to the loss of aggregate.

Table 3 Extent of the defect

<i>Extent</i>	<i>Length of block affected (per cent)</i>
1	<10
2	10-50
3	>50

Surface texture

4.11 The ability of a bituminous surfacing to provide the required skid resistance is governed by its macrotexture and microtexture. The macrotexture of the surfacing, as measured by its texture depth, contributes particularly to wet skidding resistance at high speeds by providing drainage routes for water between the tyre and the road surface. The surface condition survey should include a qualitative assessment of texture in the wheelpaths so that it can be used to trigger quantitative testing if required. As a guide, the categories shown in Table 4 (CSRA, 1992) are suggested.

Aggregate polishing

4.12 The microtexture of the surfacing, as measured by the resistance to polishing of the aggregate, is the dominant factor in wet skidding resistance at lower speeds. The assessment of polishing is more difficult

Extent = 1

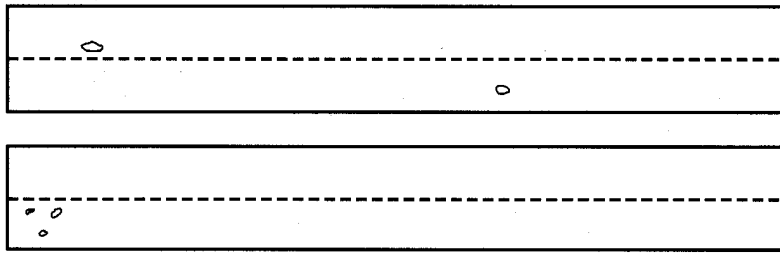

Extent = 2

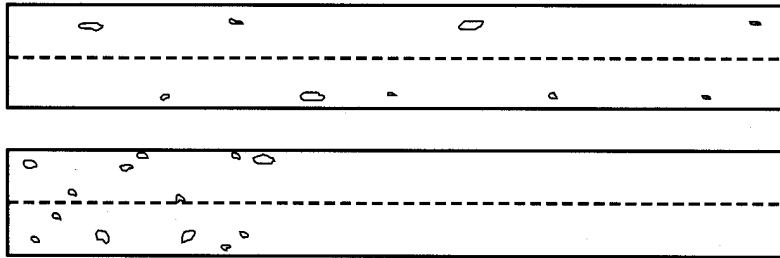

Extent = 3



Figure 4.2 Extent of potholing and patching in a 'block' (after CSRA, 1992)

Table 4 Visual assessment of surface texture

<i>Texture</i>	<i>Description</i>
Fine (F)	The surfacing is smooth and the coarse aggregate (if present) in the surfacing is not visible, eg. a sand seal, fine slurry seal or smooth asphalt.
Medium (M)	The road has a smooth appearance and will generally comprise fine aggregate. If present, any coarse aggregate is visible but the surface does not appear coarse because of fine aggregate between the coarse particles, eg. a new 6mm single surface dressing or 13/6mm double surface dressing.
Coarse (C)	The surfacing has a coarse appearance, with coarse aggregate clearly visible, eg. a new 13mm surface dressing.

than that of the surface texture, but will be unnecessary if surfacing aggregates having a satisfactory minimum Polished Stone Value were used during construction (Department of Transport, 1994a). When marginal quality aggregates have been used or if increased traffic flows have resulted in an increased state of polish, skid resistance will be reduced. The qualitative

assessment will depend on the judgement of the technician, and Table 5 (NIT'RR, 1985) is suggested as a preliminary guide.

Table 5 Visual assessment of aggregate polishing

<i>Condition</i>	<i>Value¹</i>	<i>Description</i>
Harsh (H)	>75 55-75	Stones very harsh ² , edges sharp to touch
Angular (A)	45-55 35-45	Stones sharp and angular but not harsh
Smooth (S)	<35	Stones rounded and smooth to the touch

¹ Skid resistance value (SRV) measured by the portable skid-resistance tester (RRL, 1969)

² Harsh stones have surfaces that are rough to the touch

Cracking

4.13 The assessment of cracking should fulfil two objectives. Firstly, it should identify whether the road pavement is suffering from load or non-load associated distress. Secondly, it should establish whether the severity of cracking will affect the

performance of any subsequent new pavement layer by causing reflection cracking (Rolt et al, 1996). These objectives are best achieved by identifying five characteristics of the cracking:

- type
- intensity
- position
- width
- extent

Type

4.14 Although there is often no single cause for any type of crack, its appearance can provide a guide to its likely cause. The causes of cracking are discussed in more detail in paragraphs 8.9-8.29. It is recommended that five types of crack are defined. These are listed as follows and illustrated in Figure 4.3.

- L - longitudinal cracks
- T - transverse cracks
- B - block cracks
- C - crocodile cracks
- P - parabolic cracks

Intensity

4.15 The intensity of cracking is defined by six levels described below. If the intensity of crack in varies within any block, it should be the intensity-that predominates that is recorded.

- 0 - no cracks
- 1 - single crack
- 2 - more than one crack - not connected
- 3 - more than one crack - interconnected
- 4 - crocodile cracking
- 5 - severe crocodile cracking with blocks rocking under traffic.

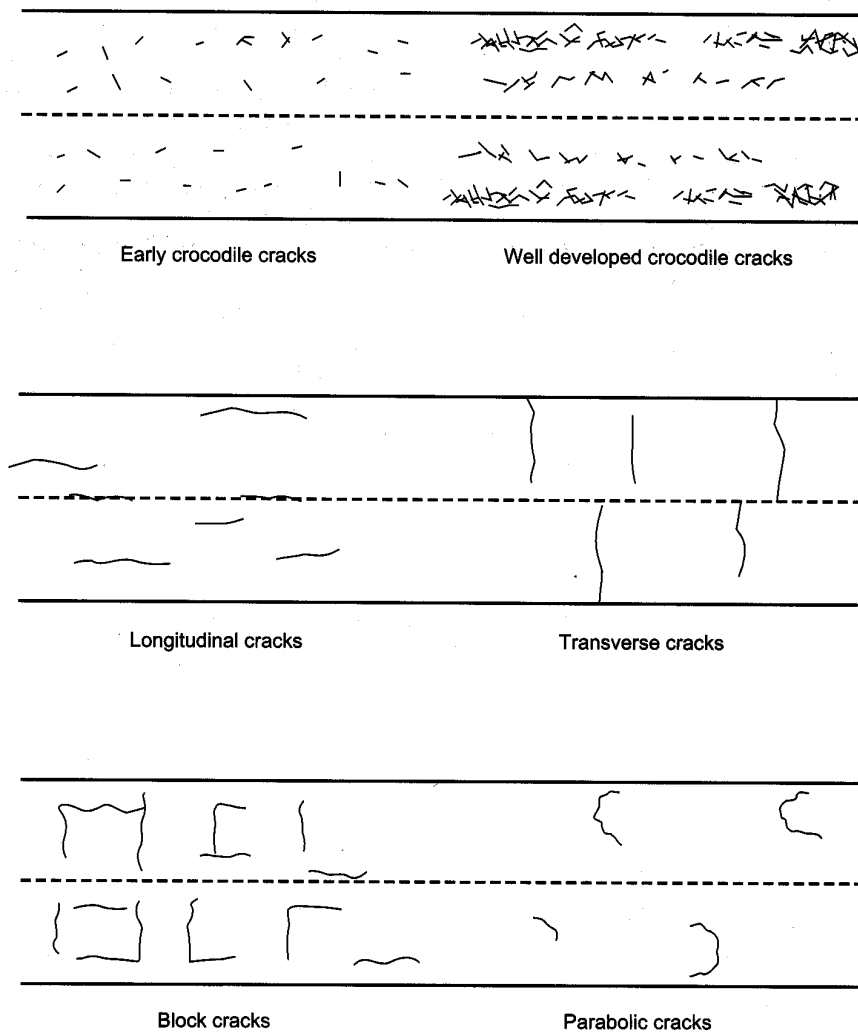

Figure 4.3 Types of cracking

Position

4.16 The position of the cracking is recorded. The cracking can be confined to either or both of the vergeside (V) and offside (O) wheelpaths, or can be spread over the entire carriageway (C/W).

Width

4.17 The measurement of crack width is difficult, but it is important because the width partly determines whether a crack can be sealed effectively. Four categories are recommended as shown below (Paterson, 1987). The first three are for cracks which are not spalled; cracks with substantial spalling are classified as width 4. Initially, until technicians are familiar with the system, the width of the cracks can be measured with a simple 'Go/No Go' gauge shown in Figure 4.4. The width of the cracks usually vary within any block, and so it is the width of crack that predominates that is recorded.

- 1 - crack width < 1mm
- 2 - 1mm < crack width < 3mm
- 3 - crack width > 3mm
- 4 - cracks with spalling

Extent

4.18 The extent of the cracking is defined as the length of block affected as shown in Table 3. The extent of cracking should be recorded irrespective of intensity.

Deformation

4.19 In terms of its assessment, pavement deformation divides into two groups. Firstly, those

defects with short wavelengths, where severity can be measured by the use of a simple 2 metre straightedge and calibrated wedge (Figure 4.5). Secondly, those defects with longer wavelengths that are best quantified by the use of more sophisticated road profiling instruments. This is discussed in paragraphs 4.28-4.30.

Rutting

4.20 Rutting is load associated deformation and will appear as longitudinal depressions in the wheelpaths. It is the result of an accumulation of non-recoverable vertical strains in the pavement layers and in the subgrade. This type of rutting is not associated with any shoving in the upper layers of the pavement unless it becomes very severe.

4.21 The width of the running surface and the traffic flow govern the number of observable wheelpaths on paved roads. For example, a 3-metre carriageway will have two wheelpaths but at road widths greater than 6.5 metres there are generally four. At intermediate widths and low traffic flows there is the possibility of three wheelpaths, with the central one being shared by traffic in both directions. Rut depths should be recorded in the wheelpath showing most rutting. On most roads this is usually the vergeside wheelpath because here the road pavement is generally weaker as a result of higher moisture contents and less lateral support. The straight-edge is placed across the wheelpath, at right angles to the direction of traffic, and the maximum rut depth recorded as shown in Figure 4.5. If the ruts are greater than 40mm deep, the wedge can be held vertically and the depth recorded to the nearest 10mm.

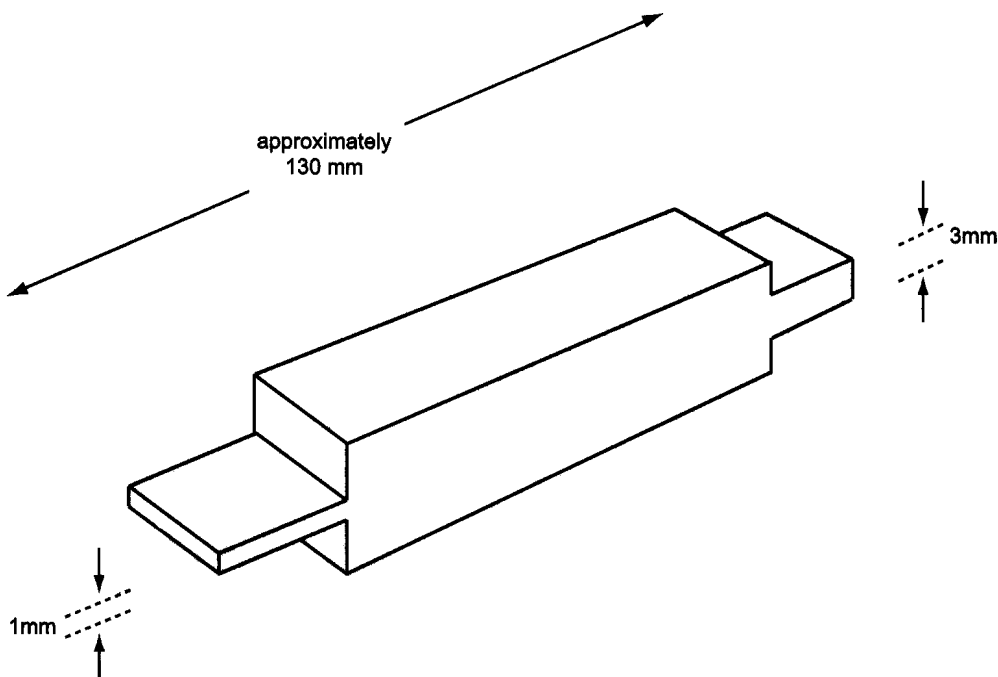

Figure 4.4 Crack width gauge

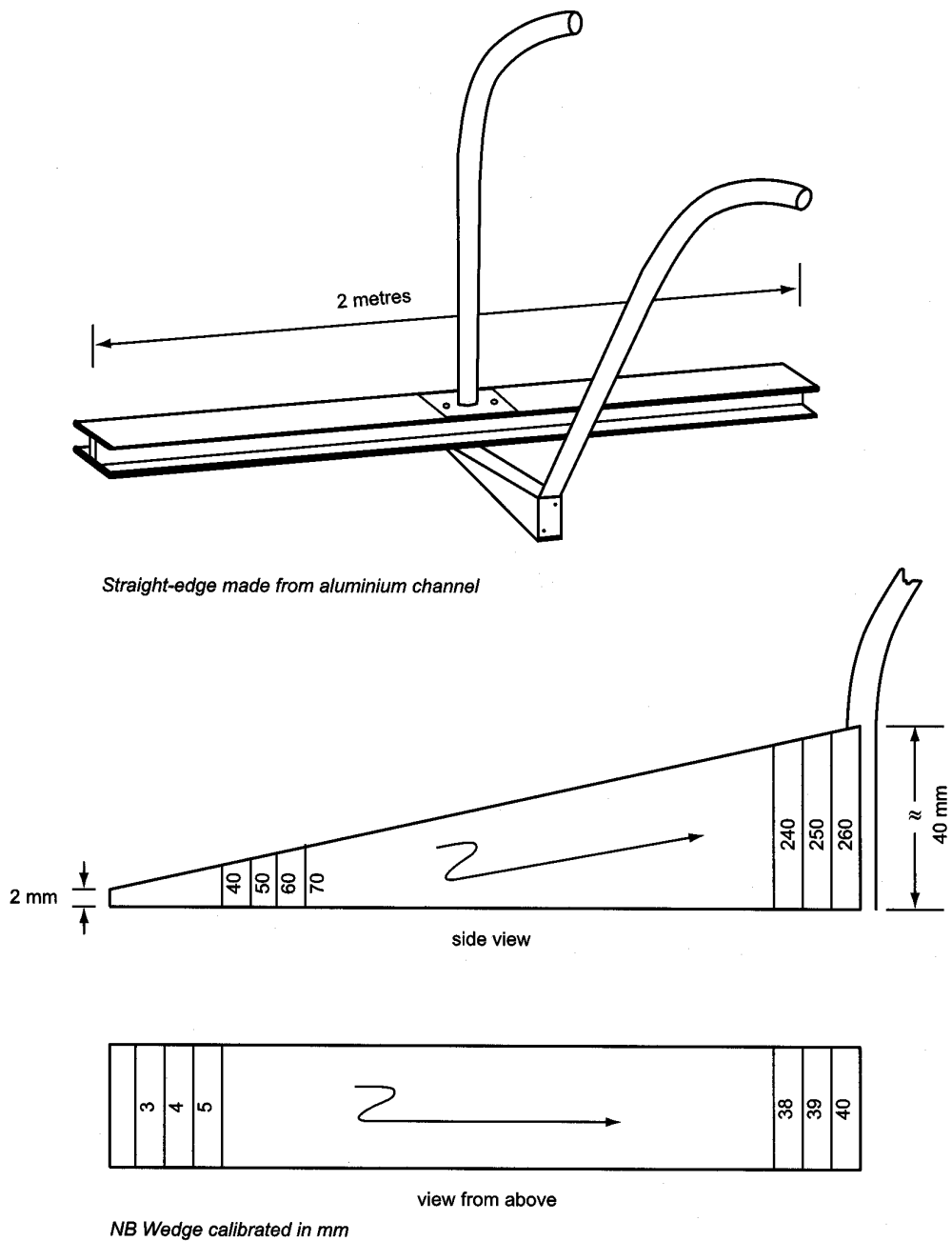

Figure 4.5 Straight edge and calibrated wedge

In some countries there are many roads where distinct wheelpaths do not exist, for example, because of a large volume of non-motorised traffic. In these circumstances the pattern of road deterioration will be different and some of the important clues relating to the position of the deterioration on the carriageway will be absent. This document does not specifically address this situation but many of the techniques for evaluation and assessment described will be appropriate to such conditions.

4.22 Rutting can also be the result of shear failure in either the unbound or the bituminous pavement layers resulting in shoving at the edge of the road

pavement. Where the shear failure is occurring in the unbound roadbase or sub-base the displaced material will appear at the edge of the surfacing. Where the failure is occurring in the bituminous material, the displaced material will be evident in the surfacing itself. This is illustrated in Figure 4.6. The severity of the shoving is difficult to measure without taking levels. However its occurrence, together with the depth of rutting, should be recorded, thereby clearly identifying the cause of the failure. This can be simply done by putting a circle around the value of rutting recorded on the surface condition form.

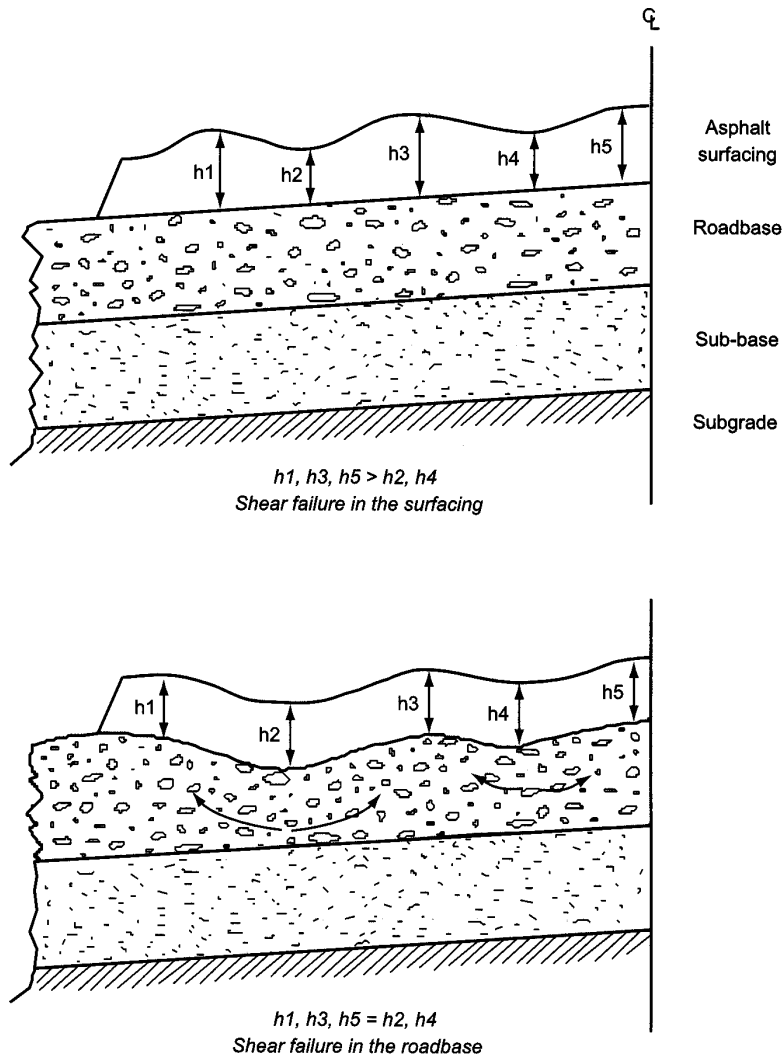

Figure 4.6 Transverse core profile to investigate rutting

Depressions

4.23 Localised depressions, caused by settlement of the pavement layers, construction faults and differential movement at structures, particularly culverts, should be recorded. These are easy to see after periods of rain as they take longer to dry than the rest of the road. When the road is dry, they can also be identified by the oil stains that occur where vehicles cross the depression. The depth should be measured using the 2 metre straight-edge and calibrated wedge.

Corrugations

4.24 Corrugations consist typically of a series of ridges perpendicular to the centre line of the road and usually extend across the whole width of the carriageway. Their spacing, or wavelength, is usually in the range of 0.5-1.0 metre but can, in some circumstances, be as much as 10 metres. In paved roads they are caused by instability in either the asphalt surfacing or in an unbound roadbase under a

thin seal. There is generally no need to measure the severity of the corrugations as it will not affect the selection of the remedial treatment. The extent of the defect is recorded as shown in Table 3.

Other types of deterioration

Potholes acid patching

4.25 Potholes are structural failures which include both the surfacing and roadbase layer. They are usually caused by water penetrating a cracked surfacing and weakening the roadbase. Further trafficking causes the surfacing to break up and a pothole develops. Because of the obvious hazard to the road user, potholes are usually patched as a matter of priority. Although patches are not necessarily defects, they do indicate the previous condition of the road and are included in the assessment. The extent of potholes and patching is recorded as shown in Figure 4.2.

Edge failures and shoulder erosion

4.26 Edge failures are caused by poor shoulder maintenance that leaves the surface of the road pavement higher than the adjacent shoulder. This unsupported edge can then be broken away by traffic, narrowing the running surface of the road. Edge failures (F) are recorded when they exceed 150mm in width at their maximum point or when the vertical step from the surfacing to the shoulder is greater than 50mm (S). It is convenient to measure the defects with the scale on the side of the calibrated wedge, shown in Figure 4.5. The length of the road affected is recorded according to Table 3.

Deterioration caused by poor drainage

4.27 Localised pavement failures are often caused by the poor design or maintenance of side and cut-off drains and cross drainage structures. When side drains and culverts silt up, water ponds against the road embankment eventually weakening the lower pavement layers. Conversely, if the water velocity in the side drain is too high it erodes the road embankment and shoulders. More general failures occur when there is no drainage within the pavement layers themselves. Paved roads do not remain waterproof throughout their lives and if water is not able to drain quickly, it weakens the lower pavement layers and results in rapid road failure. Where pavement deterioration is the result of poor drainage design or maintenance this should be recorded on the surface condition form.

Roughness measurements

4.28 It is well established that vehicle operating costs increase as the roughness of the road pavement increases (Hide et al, 1974) (Chesher and Harrison, 1987). Most of the road defects described above contribute in some way to increasing the roughness of the road pavement, although in its early stages cracking may cause little or no change. However, without proper maintenance, the cracked surfacing deteriorates and the resulting potholes and subsequent patching cause a rapid increase in roughness. Surface texture and variability in rut depth also have a significant effect on the roughness of a road pavement.

4.29 The standard measure of road roughness is the International Roughness Index (IRI) which was developed during 'The International Road Roughness Experiment' in Brazil (Sayers et al, 1986a). It is a mathematical quarter car simulation of the motion of a vehicle at a speed of 80 kph over the measured profile and can be calculated directly from road levels measured at frequent intervals. Devices for measuring levels are usually either slow and labour intensive or fast, automatic and expensive. Hence, the

roughness of the road is usually measured using a Response Type Road Roughness Measuring System (RTRRMS) which must be periodically calibrated to allow the values of roughness to be reported in terms of IRI. Suitable methods of calibration include a rod and level survey (ASTM, E 1364-95) or a standard instrument, such as the TRL Profile Beam (Morosiuk et al, 1992) or the MERLIN (Machine for Evaluating Roughness using Low-cost INstrumentation) (Cundill, 1996). Both the roughness survey and calibration procedures are described in Appendix B.

4.30 The roughness of roads with similar pavement construction is a good measure of their relative pavement condition, but it does not identify the nature of the failures or their causes. However, if resources for the surface condition survey are limited, or if the sections of the road under investigation are very long, roughness and windscreens survey data can be used to establish those lengths of road having failures of differing severity. This allows representative lengths of road to be selected which can then be used to identify the cause or causes of deterioration.

5 Localised surfacing defects

5.1 After the surface condition survey has been completed, the engineer interprets the results, decides where repairs are needed and what form of maintenance is required. To do this effectively the engineer must first identify the causes of the deterioration. This is important as it is likely that treating the symptoms of pavement deterioration

rather than their causes will prove unsatisfactory. When the road pavement is either rutted or cracked, a programme of additional testing is usually required to establish the causes. However, there are some surfacing defects, if localised, which can be treated at this stage without the need for further testing. Suggested treatments for these types of pavement distress are summarised in Tables 6 and 7.

Table 6 Surfacing defects - roads with thin bituminous seals

<i>Defect</i>	<i>Extent</i>	<i>Maintenance treatment</i>	<i>Notes</i>
Fretting	<10%	Local patching	A fog spray may be sufficient to rejuvenate the surface and prevent further fretting.
	>10%	Surface dressing or slurry seal	
Loss of stone, bleeding and fatting-up	<10%	No action	Local application of heated aggregate may be required if poor skid resistance is a problem.
	>10%	Additional tests required ¹	
Loss of texture and/or polishing of aggregate	<10%	No action	
	>10%	Additional tests required ¹	
Potholes	Any	Patch	Potholes are the result of other failures such as cracking and deformation and additional tests will usually be necessary
Edge failures	Any	Patch road and reconstruct the shoulder	

¹ *Quantitative tests are required to establish the extent and severity of the problem (see paras 7.14-7.17).*

Table 7 Surfacing defects - roads with asphalt surfacings

<i>Defect</i>	<i>Extent</i>	<i>Maintenance treatment</i>	<i>Notes</i>
Fretting or stripping	<10%	Local patching	Application of a proprietary rejuvenator may prevent further fretting.
	>10%	Patching followed by surface dressing or slurry seal	
Bleeding or fatting-up	<10%	No action	Local application of heated fine aggregate may be required if poor skid resistance is a problem.
	>10%	Additional tests required ¹	
Loss of texture and/or polishing of aggregate	<10%	No Action	
	>10%	Additional tests required ²	
Potholes	Any	Patching	Potholes are the result of other failures such as cracking and deformation and additional tests will usually be necessary
Edge failures	Any	Patch road and reconstruct the shoulder	

¹ *Additional tests are required to establish the cause of bleeding. When severe, the surfacing may have to be removed prior to resurfacing.*

² *Quantitative tests are required to establish the extent and severity of the problem (see paras 7.14-7.17).*

6 Performance charts

6.1 Apart from the surface defects described in Tables 6 and 7, bituminous surfaced roads will generally deteriorate either by rutting or by cracking. It is important that the initial form of deterioration and its cause is identified, because this determines the type of maintenance that is most appropriate. After further trafficking, the initial cause of deterioration can be masked by subsequent deterioration. An illustration of this is shown in Figure 6.1, where the final appearance of the road deterioration is similar despite having different initial causes. It is also important to establish if the failures are localised, perhaps because of poor drainage, or whether they are affecting the road in a more general manner.

6.2 When an evaluation takes place there will often be considerable lengths of road that have reached a terminal level of deterioration similar to that shown in Figure 6.1. However, even within nominally uniform sections, road pavements are inherently variable, having a range of pavement thicknesses and material properties. This results in differential performance, with some areas deteriorating less rapidly than others, and it is in these areas that the initial form of deterioration can be most easily identified.

6.3 The cracking or rutting recorded during the windscreen or detailed condition survey may be displayed graphically in the form of performance charts. These enable the length of road affected by each form of deterioration to be quantified. The cracking and rutting can also be compared to other predominant forms of deterioration and this may help to promote a better understanding of the causes.

6.4 An example of the use of performance charts is illustrated in Figure 6.2 for a 20km section of paved road having a mechanically stabilised gravel roadbase with a thin bituminous surfacing. The initial form of deterioration was rutting which was associated with shoving whenever the failure became severe. Although there is some cracking which is coincident with high values of rutting, there is no cracking in areas of less severe rutting, suggesting that the rutting preceded the cracking. In addition to the rutting, substantial lengths of the surfacing are suffering from bleeding. However, the charts show that there is no correlation between the bleeding and the rutting, indicating that the shoving is in a lower granular layer, not the bituminous surfacing.

6.5 Using performance charts similar to those described above, the section is divided into subsections having failures of differing severity. A programme of additional tests (see Chapter 7) is then prepared to identify the causes of the differential performance between the sub-sections. There may be some cases where the complete section of road will have reached a failed condition, for example when

the road pavement has been under designed or where there are serious material problems. In such cases the cause of the deterioration can only be established by comparing the thickness of the road pavement or the material properties of the pavement layers with relevant design standards and material specifications.

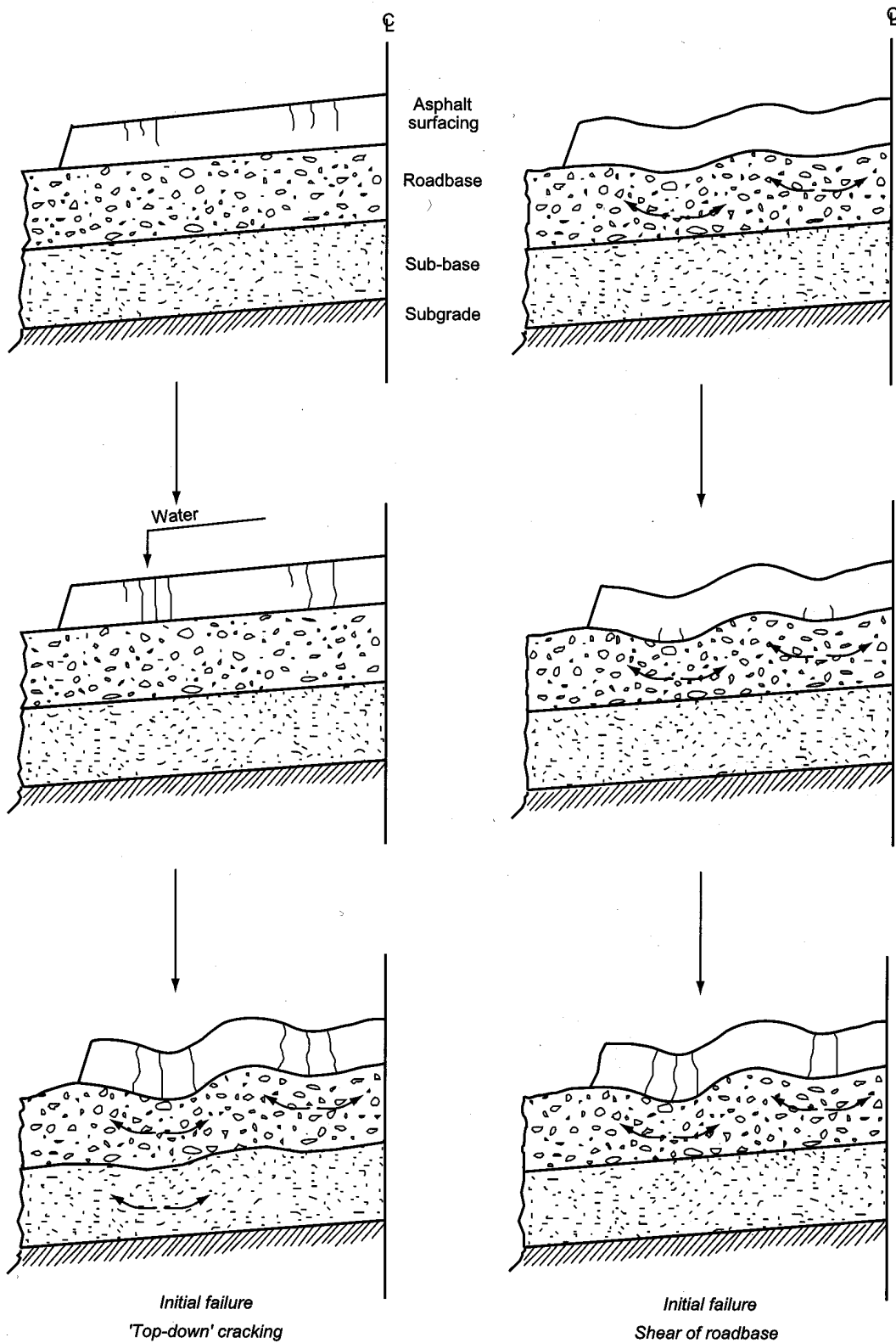

Figure 6.1 The development of road failure

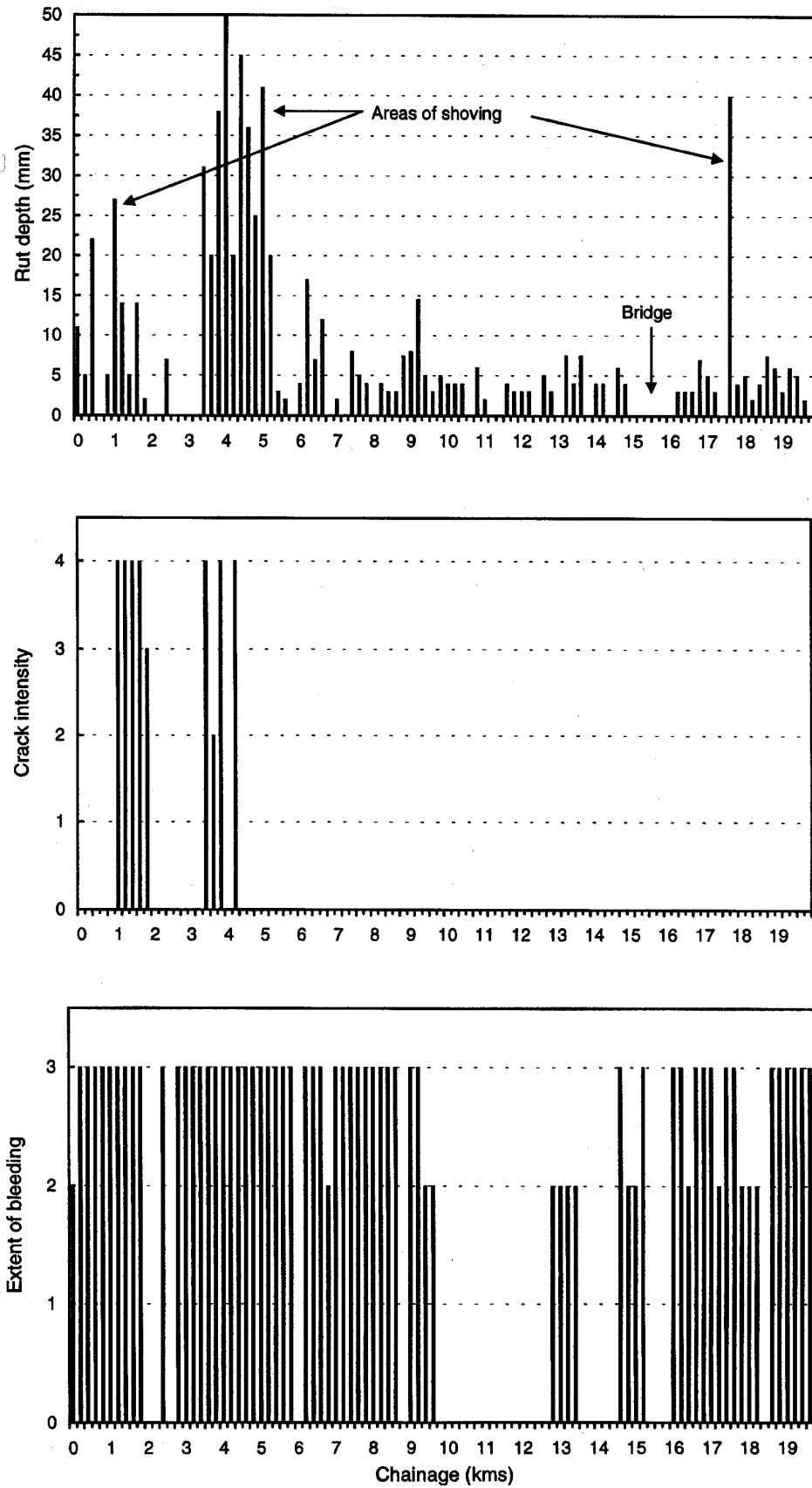

Figure 6.2 Illustration of performance charts

7 Additional tests

7.1 Deflection-based measurements and Dynamic Cone Penetrometer (DCP) tests are used to help identify the cause of differential performance between sub-sections and to provide information for the maintenance or rehabilitation of the section. In some cases the moisture content of the road pavement, especially the subgrade, changes seasonally. In these circumstances the tests should be carried out after the rainy season, when the road is at its weakest. The results from these non-destructive tests are usually confirmed by destructive sampling and material testing.

Deflection tests

7.2 The strength of a road pavement is inversely related to its maximum vertical deflection under a known dynamic load. Table 8 lists the more common deflection devices, their loading regimes and output.

Table 8 Deflection devices

<i>Device</i>	<i>Type of applied load</i>	<i>Output</i>
Deflection beam	Moving wheel	Maximum deflection
Deflectograph	"	Deflection bowl ¹
Road Rater	Vibratory load	"
Dynalect	Oscillatory load	"
Falling Weight Deflectometer	Impact load	"

1 Maximum deflection is one parameter in the deflection bowl

7.3 The least expensive of these instruments is the deflection beam. This is a mechanical device that measures the maximum deflection of a road pavement under the dual rear wheels of a slowly moving loaded lorry. The recommended test and survey procedures for the deflection beam are given in Appendices C and D. TRL recommends the use of a 63.2 kN rear axle load, other authorities recommend different loads, most commonly 80 or 100 kN. Over this range of loads the maximum deflection is usually linearly related to the applied load. Therefore, for structurally adequate pavements where over-stressing is not a danger, deflection values can be measured with these higher loads and then normalised to any standard load for comparison purposes.

7.4 Maximum deflection under a slowly moving wheel load is a good indicator of the overall strength of a pavement and has been shown to correlate well with long term performance of pavements under traffic. For example, if a road is underdesigned for the traffic it is carrying for any reason (eg. incorrect assessment of subgrade strength or traffic loading) the stresses in the lower layers of the pavement will

be too high and the pavement will deteriorate through the development of ruts. Under such circumstances the deflection will be correlated with rut depth, as shown in Figure 7.1, and such a correlation provides an indication of the reasons for failure.

7.5 Apart from the maximum deflection, there are other parameters and indicators from the deflection bowl that may be used to identify some of the structural differences between sub-sections and hence assist in identifying the cause, or causes, of failure. The radius of curvature (ROC) of the deflection bowl, shown in Figure 7.2, can be used to estimate the relative properties of the upper layers of the pavement. This may be used to identify relatively weaker surfacing layers where fatigue cracking is more likely. However, once cracking is apparent the ROC will decrease considerably hence care is required in interpreting the ROC data. Similarly the deflection values at the extremes of the deflection bowl are indicators of the relative strength of the subgrade.

7.6 Therefore there are advantages in using deflection equipment capable of measuring other deflection bowl parameters as well as maximum deflection and the Falling Weight Deflectometer (FWD) and the Deflectograph are the most widely used. The FWD, in particular, is growing in popularity as it has the advantage of being able to apply impact loads which more accurately simulate the effect on pavements of heavy vehicles moving at normal traffic speeds than the slowly moving load applications associated with the Deflectograph or the deflection beam. Procedures for using FWD equipment for road surveys are given in Appendix E. If, however, funds are not available to measure deflection bowl characteristics using one of the more sophisticated measuring devices, then consideration should be given to using a curvature meter (NIRR, 1970) in association with a deflection beam to measure both the ROC under the rear wheels of the deflection lorry and the maximum deflection.

7.7 Analysis of deflection bowl data is dependent on a suitable model to calculate the response of the pavement to the applied load. Most analysis programs are based on the assumption that the pavement behaves, in the first instance, like a multi-layer structure made up of linearly elastic layers. Using such a model, it is possible to calculate the elastic modulus of each pavement layer from a knowledge of the shape of the deflection bowl. This 'back-analysis' procedure requires accurate deflection data extending from the central maximum deflection out to deflection values at radial offsets of as much as 2.1 metres. However, the linear elastic model is a very simple model of road pavements. Road materials display a variety of properties that do not comply with the assumptions of the model. For example, the elastic modulus of unbound materials is not a constant but depends on the stresses to which

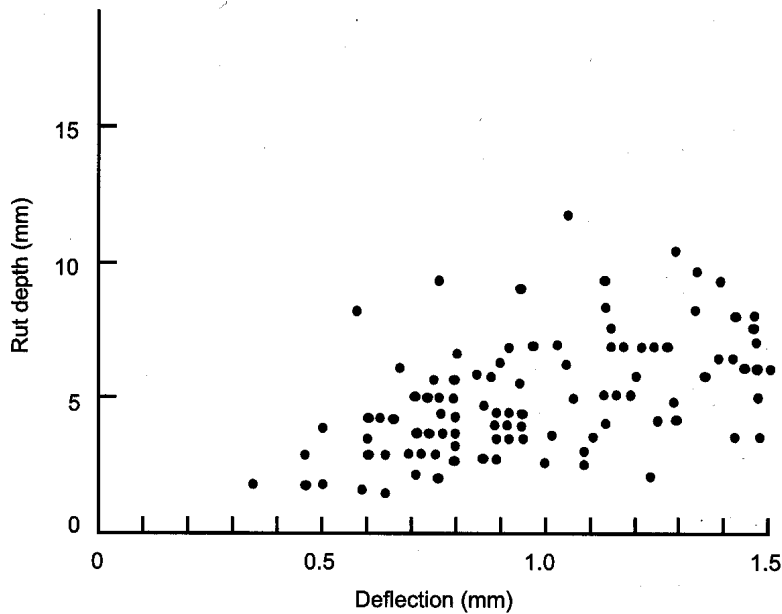

Figure 7.1 Example of good relation between rut depth and deflection

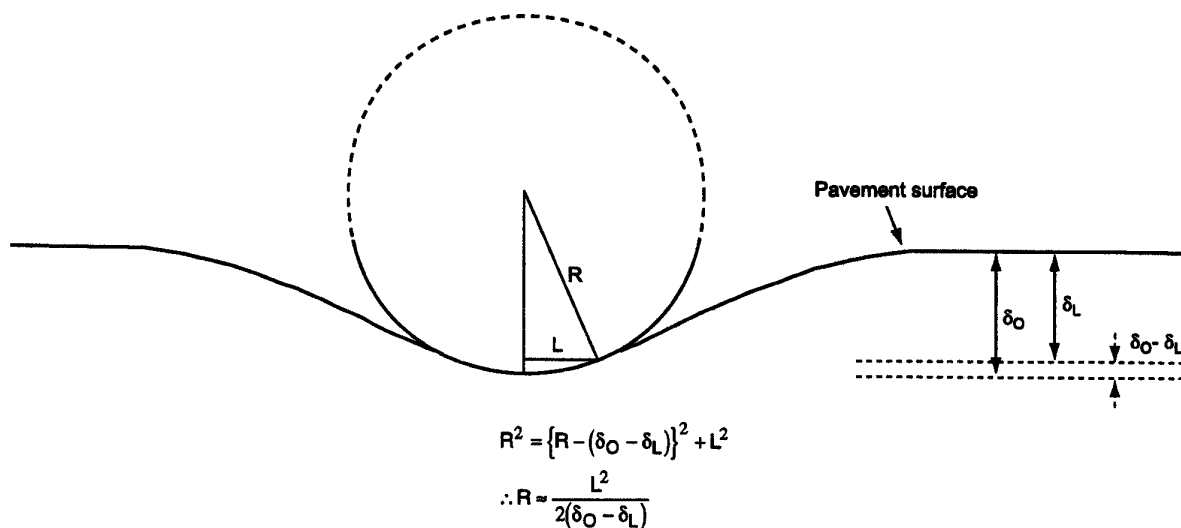

Figure 7.2 Computation of radius of curvature

the material is subjected at each point in the structure, i.e. the materials are not linear. This is a particular problem with the subgrade because the modulus of the subgrade has a strong influence on the shape of the entire deflection bowl. Errors or inaccuracies in the assumptions here, give rise to errors in the calculations of the moduli of all other layers. A further consideration is the capability of the programs to handle complex structures. The more layers that are present, the more difficult it is for the programs to identify a suitable unique solution. Overall, the acceptability of the results often depends much more on the skill of the analyst than the sophistication of the analysis program. Recent research (Strategic Highway Research Program,

1993a) has resulted in a set of rules and guidelines that can be used when estimating pavement layer moduli by back-calculation from deflection bowl data and it is considered that these provide a reasonable basis for the back-analysis of road pavements.

7.8 Alternatively FWD deflection data may be tabulated and plotted to show the variation of pavement response along the road. Certain parts of the deflection bowl are influenced by the different pavement layers. With reference to Table E1 (Appendix E), the chosen deflection criteria are usually d1, d6 and (d1-d4). The maximum deflection d1 gives an indication of overall pavement performance whilst the deflection difference (d1-d4)

relates to the condition of the bound pavement layers. Deflection d_6 is an indicator of subgrade condition. A typical deflection profile is shown in Figure 7.3. Although actual values of deflection will depend on the type and condition of the pavement layers, such plots show relative differences in their condition and give an indication of any structural weaknesses.

Dynamic cone penetrometer tests

7.9 The DCP is an instrument which can be used for the rapid measurement of the in situ strength of existing pavements constructed with unbound materials. Measurements can be made down to a depth of approximately 800mm or, when an extension rod is fitted, to a depth of 1200mm. Where pavement layers have different strengths, the boundaries between them can be identified and the thickness of each layer estimated. The operation of the DCP and the analysis of the results are described in Appendix F.

7.10 DCP tests are particularly useful for identifying the cause of road deterioration when it is associated with one of the unbound pavement layers, eg. shear failure of the roadbase or sub-base. A comparison between DCP test results from subsections that are failing and those that are sound will quickly identify the pavement layer which is the cause of the problem.

7.11 In some circumstances it is convenient to convert the individual pavement layer thicknesses and strengths measured in the DCP test into a simple

numeric which represents the combined strength of the pavement layers. This is done by calculating the Structural Number (SN) as shown in Equation 1.

$$SN = 0.0394 \sum_0^i a_i d_i \quad (1)$$

where a_i = Layer coefficient of layer i

d_i = Thickness of layer i (mm)

The layer coefficients are related to standard tests for the pavement materials and are fully described in the AASHTO Guide for Design of Pavement Structures (1993).

To take into account variations in subgrade strength, the modified structural number (SNC) can also be calculated (Hodges et al, 1975), as shown in Equation 2.

$$SNC = SN + 3.51 (\log_{10} CBR) - 0.85 (\log_{10} CBR)^2 - 1.43 \quad (2)$$

where CBR = in situ CBR of the subgrade.

If it is suspected that the road failures are related to the overall structural strength of the pavement, the Modified Structural Number of different sub-sections can be readily compared to identify the weakness.

Destructive sampling and material testing

7.12 When the results of the condition survey indicate that the properties of the asphalt surfacing could be the cause of differential performance between sub-sections (see paras 8.1-8.29) then this should be

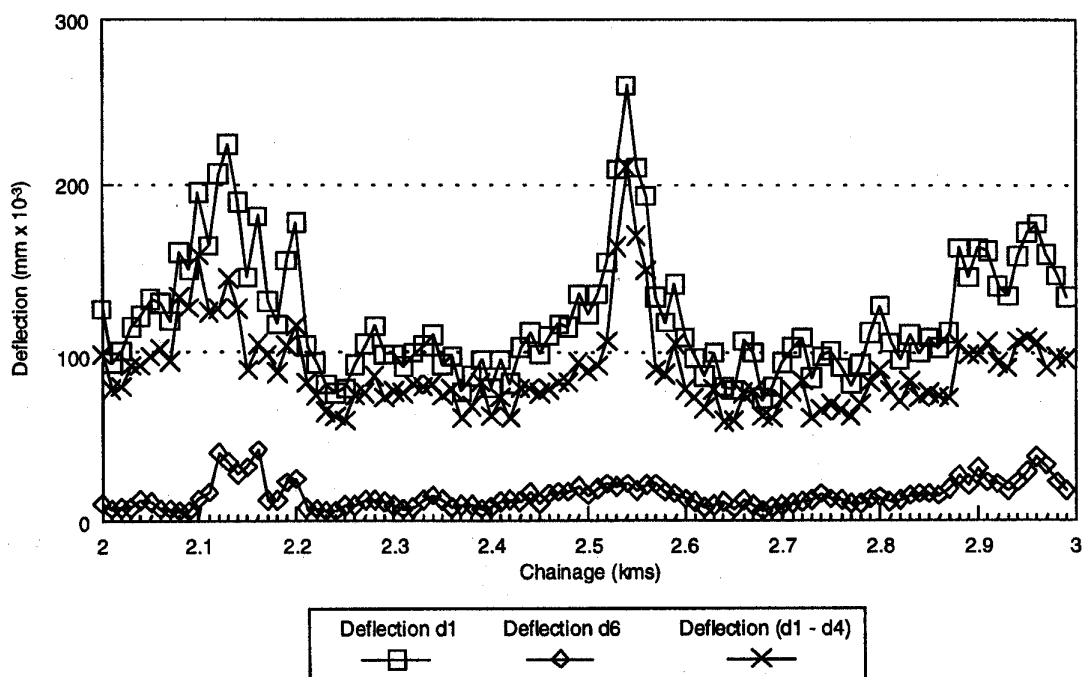

Figure 7.3 FWD deflection profile

confirmed by further testing. Sufficient 150mm diameter core samples need to be taken from each subsection to ensure that representative values for the composition and properties of the asphalt surfacing are obtained (BS 598, 1987). Prior to testing, the cores must be examined to establish the following:

- thickness of each bound layer;
- degree of bonding;
- occurrence of any stripping; and
- depth of cracking (if required).

Where only the thickness of the asphalt surfacing is to be measured, then 50-100mm diameter cores are satisfactory. Similar cores can be used for transverse core profiles, such as those shown in Figure 4.6, which are used to establish whether shoving is the result of shear failure in the surfacing or in one of the lower unbound pavement layers.

7.13 When deflection measurements and DCP results indicate that either the thickness or properties of the lower pavement layers are the cause of the differential performance, then test pits are needed to obtain additional material information to confirm these results. The recommended procedure for carrying out test pit investigations is given in Appendix G. These investigations are used both to provide an explanation for the present behaviour of the pavement and to provide information for its rehabilitation. Each test pit will provide information on the thickness of each pavement layer and properties of the material. These can then be compared to specified values.

Skid resistance tests

7.14 When the detailed surface condition survey indicates that the surfacing has poor texture or polished aggregate (see Tables 6 and 7) then a quantitative survey will usually be required. This survey can only be dispensed with if the road is suffering from other failures that require the road to be resurfaced.

7.15 The texture depth of bituminous surfacings is measured by the sand patch test (BS 598, 1990). The test procedure is described in Appendix H. There are also other relatively low cost instruments, such as the Mini-Texture Meter (Department of Transport, 1994a), which give continuous measurements of surface texture and are quicker and more convenient to use. However, the results from texture meters need to be calibrated against the sand patch test if they are to be compared with specifications. The sand patch test gives a single value of texture at one point and therefore a number of tests are needed to give a representative value for the road. This is done by selecting sections of road, 50 metres long, which cover the range of severity of the defect recorded

during the detailed condition survey (see Table 4). A mean of ten tests, usually in the vergeside wheelpath, should be used to characterise each 50 metre section. Sections should also be chosen in hazardous areas such as the approaches and crowns of bends. These values can then be compared to national standards, where they have been established, to identify the lengths of the road that need resurfacing. If national standards do not exist then the intervention values proposed in the UK may be used as a guide (Department of Transport, 1994b).

7.16 The microtexture, in terms of the 'skid resistance' value (SRV), can be measured using the portable skid-resistance tester (RRL, 1969) (ASTM, E 303-93). The test procedure is described in Appendix 1. There are other instruments available which measure skid resistance more rapidly (and more continuously), for example SCRIM (Sideway-force Coefficient Routine Investigation Machine)(Department of Transport, 1994a) and the Griptester (County Surveyors Society, 1988), but these are more costly. A representative value of SRV can be obtained in a similar way to that described for texture depth, with the mean value of ten results being used to characterise a 50 metre section of road. These values can then be compared to national standards, where they have been established, to identify the lengths of the road in need of resurfacing.

7.17 If national standards are not available then those recommended in the UK may be used as a guide (Department of Transport, 1994a). The present UK intervention levels are now specified in terms of the Sideway-Force Coefficient (SFC) as measured by SCRIM. If only the portable skid resistance tester is available, then previous UK standards, summarised in Table 9, are suggested as a preliminary guide.

Table 9 Suggested minimum 'skid resistance' values

<i>Type of site</i>	<i>Minimum SRV @ 20°C</i>
Difficult sites such as:	65
Roundabouts	
Bends with a radius less than 50m on unrestricted roads	
Gradients, 1 in 20 or steeper, of lengths greater than 100m	
Approaches to traffic lights on unrestricted roads	
Motorways, trunk and class 1 roads and heavily trafficked roads in urban areas (carrying more than 2000 vehicles per day)	55
All other sites	45

8 Identifying the causes of pavement deterioration

8.1 The next stage in the evaluation procedure is to establish the cause or causes of the pavement deterioration by interpreting the data collected during the surface condition survey and the additional testing. The causes of deterioration combined with the extent of the failures must be considered together when selecting the most appropriate method of maintenance or rehabilitation.

8.2 Besides the surface defects described in Tables 6 and 7, bituminous surfaced roads will generally deteriorate either by rutting or by cracking. To help identify the cause of the deterioration, rutting and cracking have been subdivided into six categories based on the nature of the failure, its position and the type of road construction. These are:

- rutting without shoving;
- rutting with shoving;
- wheelpath cracking - asphalt surfacing;
- wheelpath cracking - thin bituminous seal;
- non-wheelpath cracking - asphalt surfacing; and
- non-wheelpath cracking - thin bituminous seal.

8.3 A method of establishing the probable cause or causes of pavement deterioration is given in the flow charts shown in Figures 8.1-8.8. These charts will not cater for all the types and stages of pavement deterioration. In particular, when a road has received a series of maintenance treatments or when the initial deterioration is masked by further progressive failures, the problem of identifying the initial cause of failure becomes more complex. However, the charts do provide a framework that enables highway engineers to develop their own pavement evaluation skills. The charts identify general causes of deterioration but do not attempt to establish specific material problems, as this can only be done by further destructive sampling and subsequent laboratory testing.

Rutting without shoving (Figure 8.1)

8.4 These ruts are usually wide as they are caused primarily by movement deep in the pavement structure, and there will be little or no evidence of shoving at the edge of the pavement. This type of rutting is the result of two possible causes, either insufficient load spreading or secondary compaction.

8.5 Insufficient load spreading is the result of the pavement layers being too thin to protect the subgrade. It is characterised by an increase in rutting with traffic loading. Where there is historical data on the progression of rutting and traffic, or where there is a significant difference in traffic loading between the two lanes, then this relationship can be established. More usually this information will not be available and

it will then be necessary to show a relationship between the severity of rutting and the deflection of the road pavement at the time of the evaluation, as illustrated in Figure 7.1. If deflection equipment is unavailable, a similar analysis can be completed by relating the severity of rutting to the strength of the road, as measured by the DCP (see para 7.11).

8.6 If the severity of rutting does not relate to the strength of the road pavement, the most likely cause of the rutting is secondary compaction of one or more of the pavement layers by traffic during the early life of the road. In this case the rate of increase in rutting will decrease after the initial compaction phase.

Rutting with shoving (Figure 8.2)

8.7 Shoving parallel to the edge of the rut (see para 4.22) is indicative of a shear failure in one of the pavement layers and is caused by the pavement layer having inadequate shear strength to withstand the applied traffic stresses at that particular depth in the pavement. Unlike the rutting described in paragraph 8.5, the severity of the rutting will not usually be related to the overall strength of the pavement as indicated by either its deflection or modified structural number.

8.8 The failures are usually confined to the upper pavement layers where the applied traffic stresses are at their highest. A process of elimination is used to identify which layer has failed. If the pavement has an asphalt surfacing then a transverse core profile (Figure 4.6) can be used to establish in which bituminous layer, if any, the failure is occurring. If the failure is not in the asphalt surfacing then the DCP can be used to identify which of the underlying pavement layers is the cause of the failure. This is done by comparing the strength of the layers in failed areas with those that are sound. For roads with thin bituminous seals, a comparison of the ROC values from these different areas can also be used to identify substandard roadbase materials.

Wheelpath cracking - asphalt surfacing (Figure 8.3)

8.9 If cracking is caused primarily by traffic it must, by definition, originate in or near the wheelpaths. In severe cases it is sometimes difficult to be sure whether the failures start in the wheelpath or whether they are a progression of another form of cracking, as shown in Figure 8.9 (Dickinson, 1984). The initial type of cracking should be identified as described in paragraphs 6.1-6.2.

8.10 Short irregular longitudinal cracks in the wheelpaths are often the first stage of traffic induced fatigue of the surfacing which, after further trafficking, interconnect to form crocodile cracks (see Figure 8.9). Although caused by the flexure of the surfacing, they are not necessarily 'traditional' fatigue cracks which start at the bottom of the asphalt surfacing and

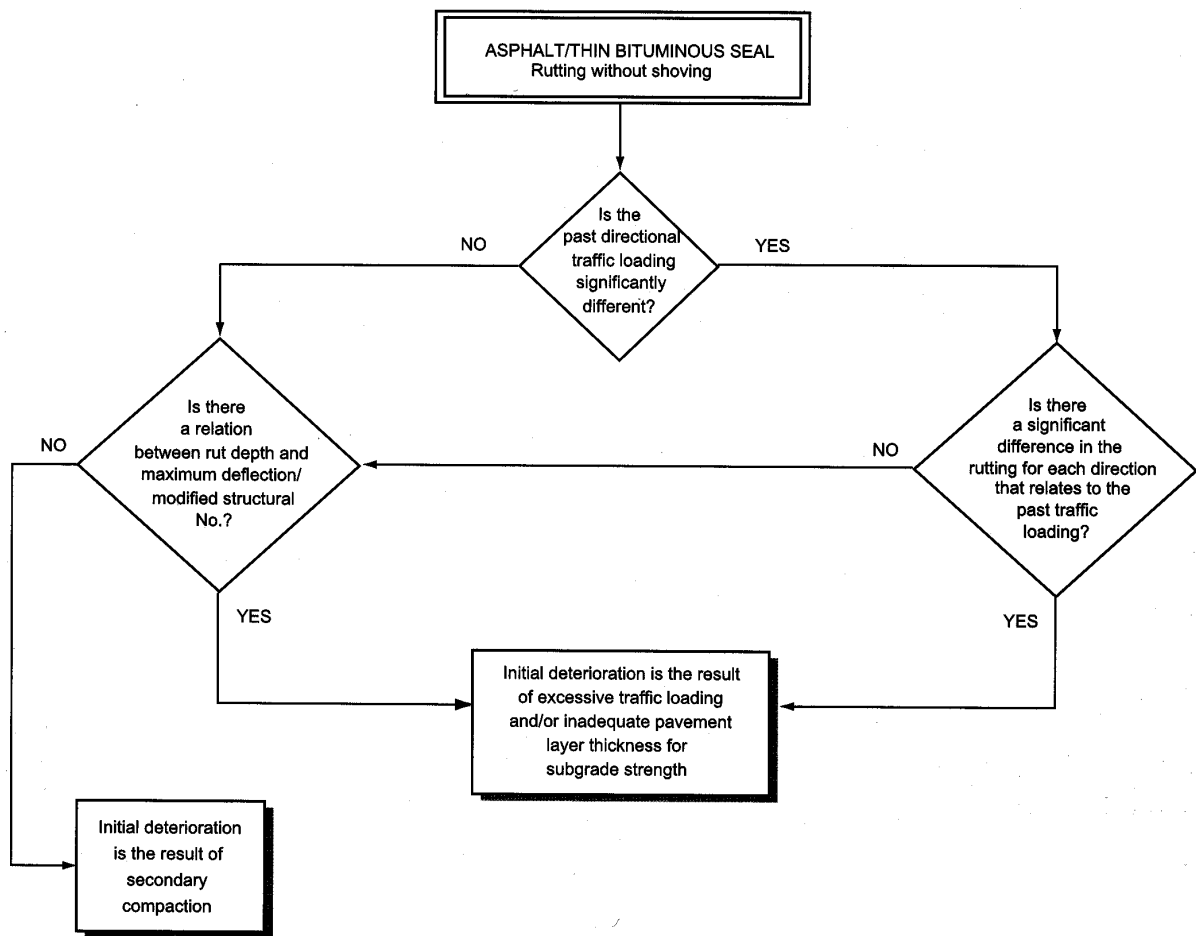

Figure 8.1 Initial deterioration - Rutting without shoving

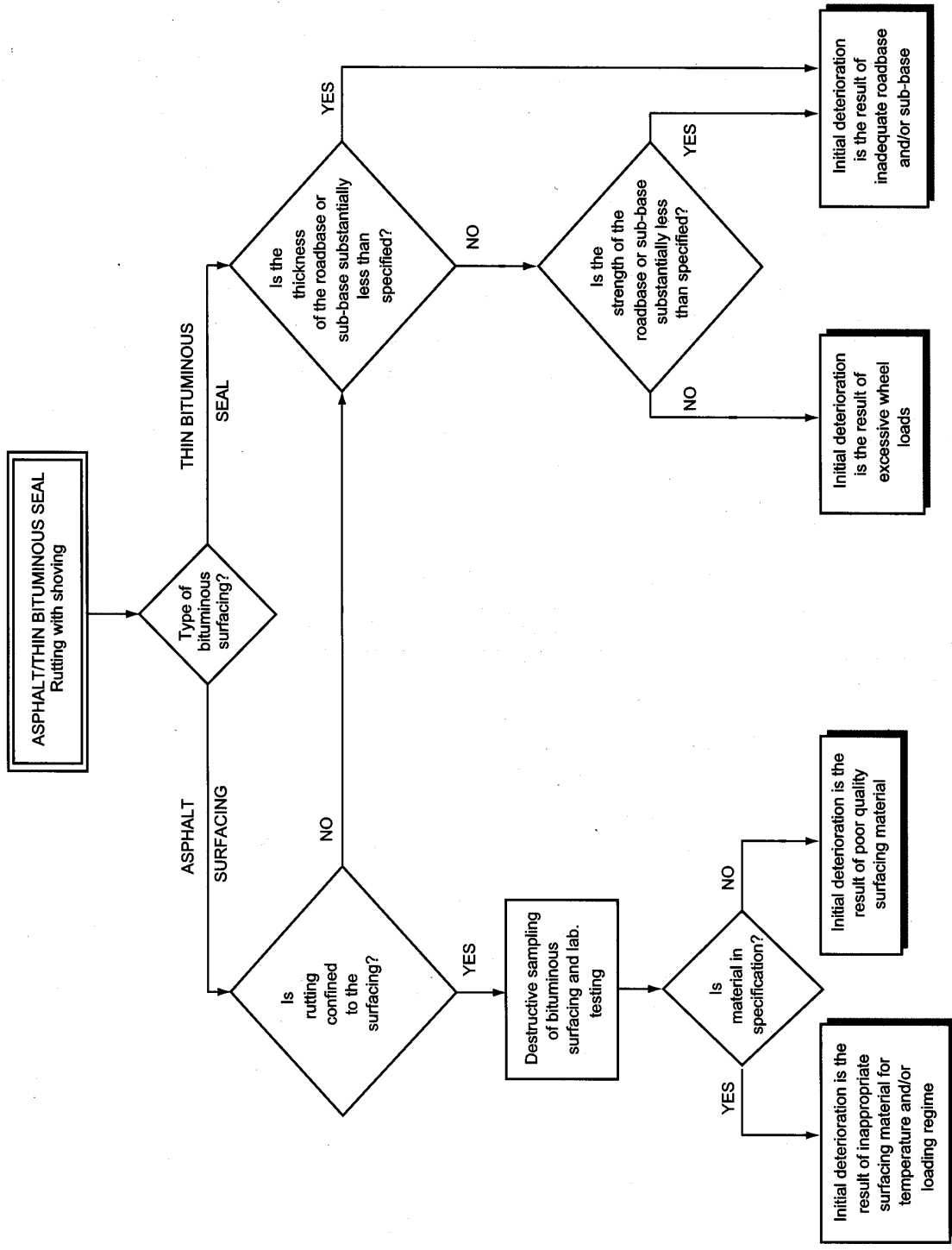

Figure 8.2 Initial deterioration - Rutting with shoving

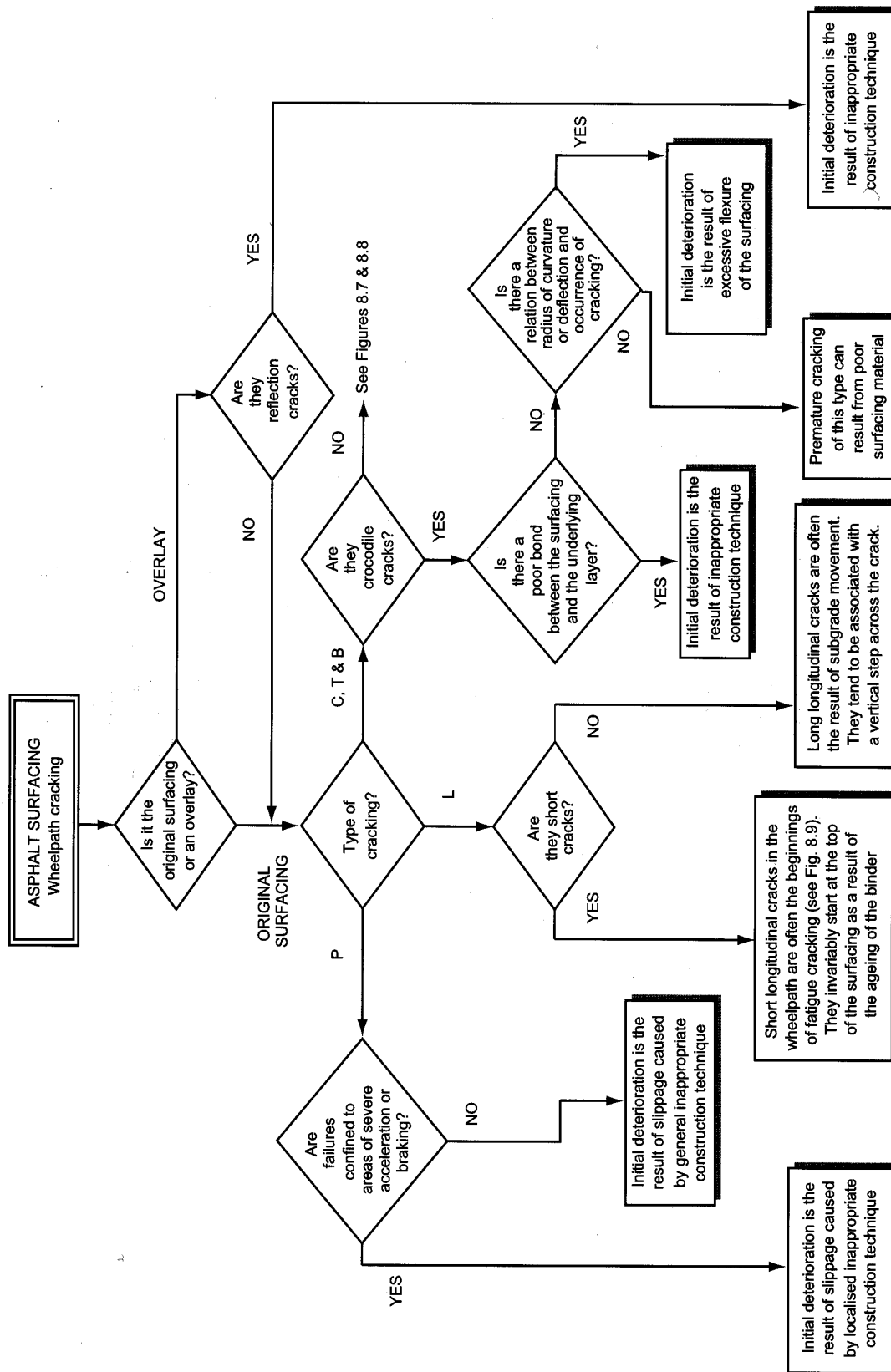

Figure 8.3 Initial deterioration - Wheelpath cracking in asphalt surfacing

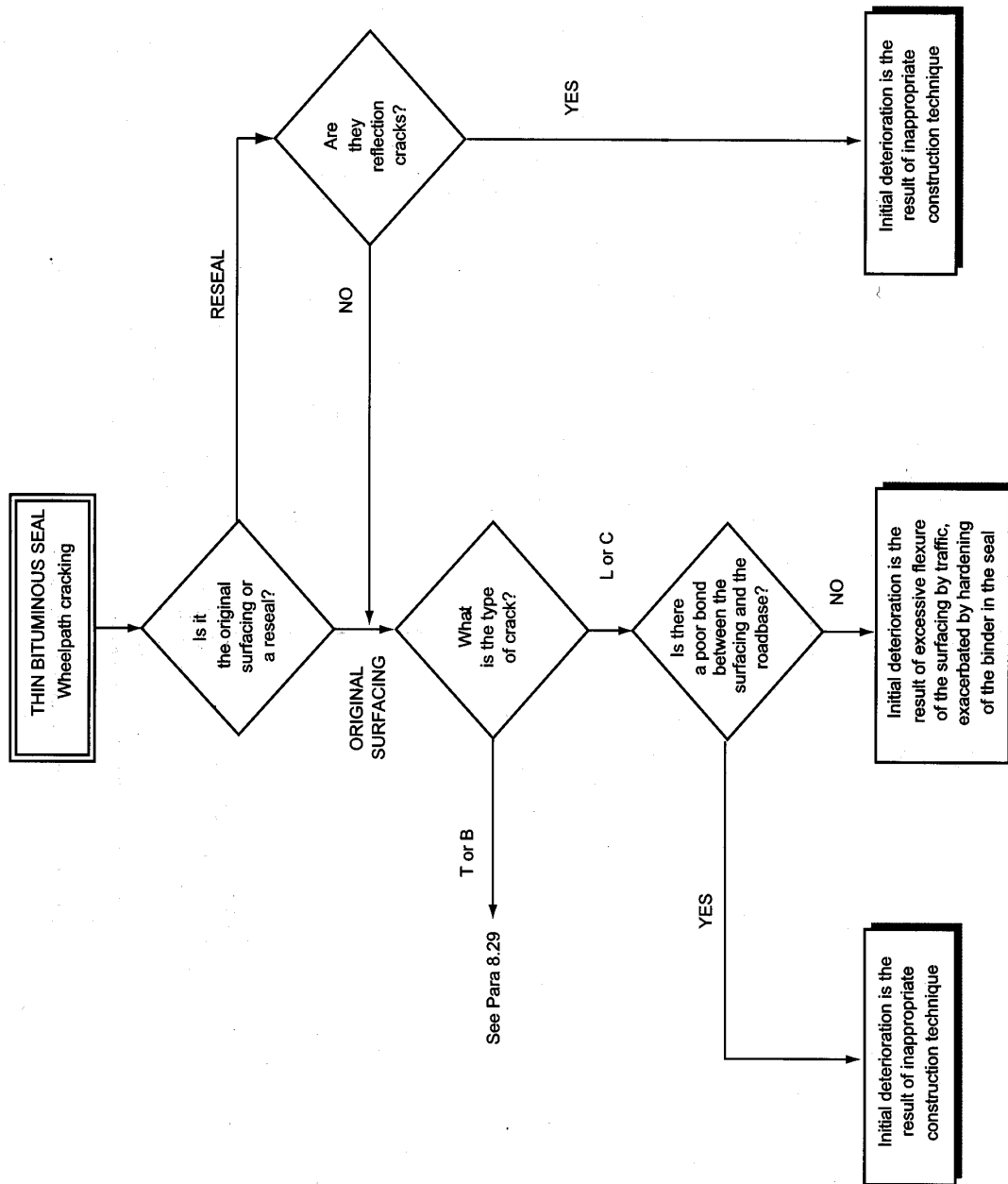

Figure 8.4 Initial deterioration - Wheelpath cracking in thin bituminous seal

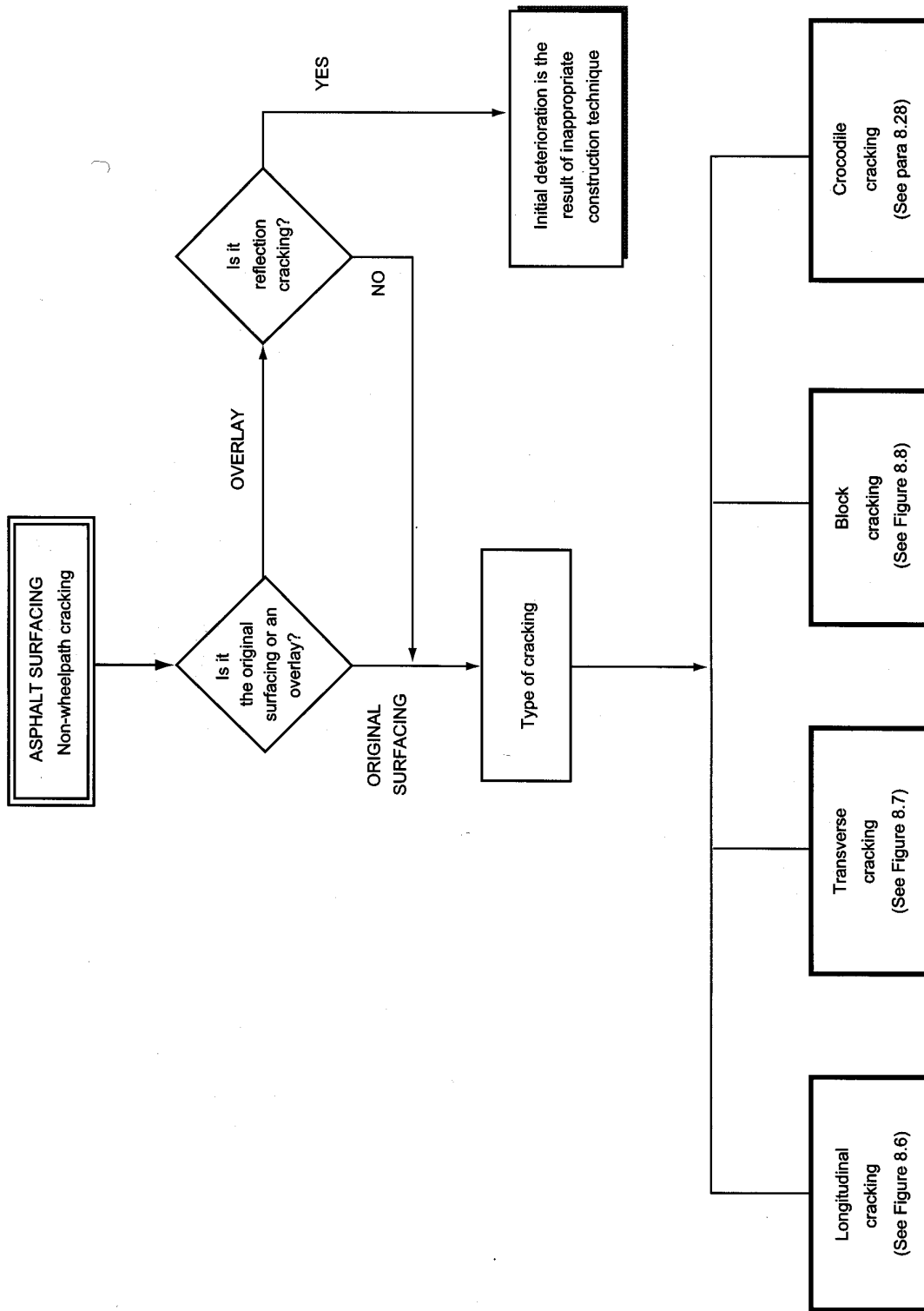

Figure 8.5 Initial deterioration - Non-wheelpath cracking in asphalt surfacing

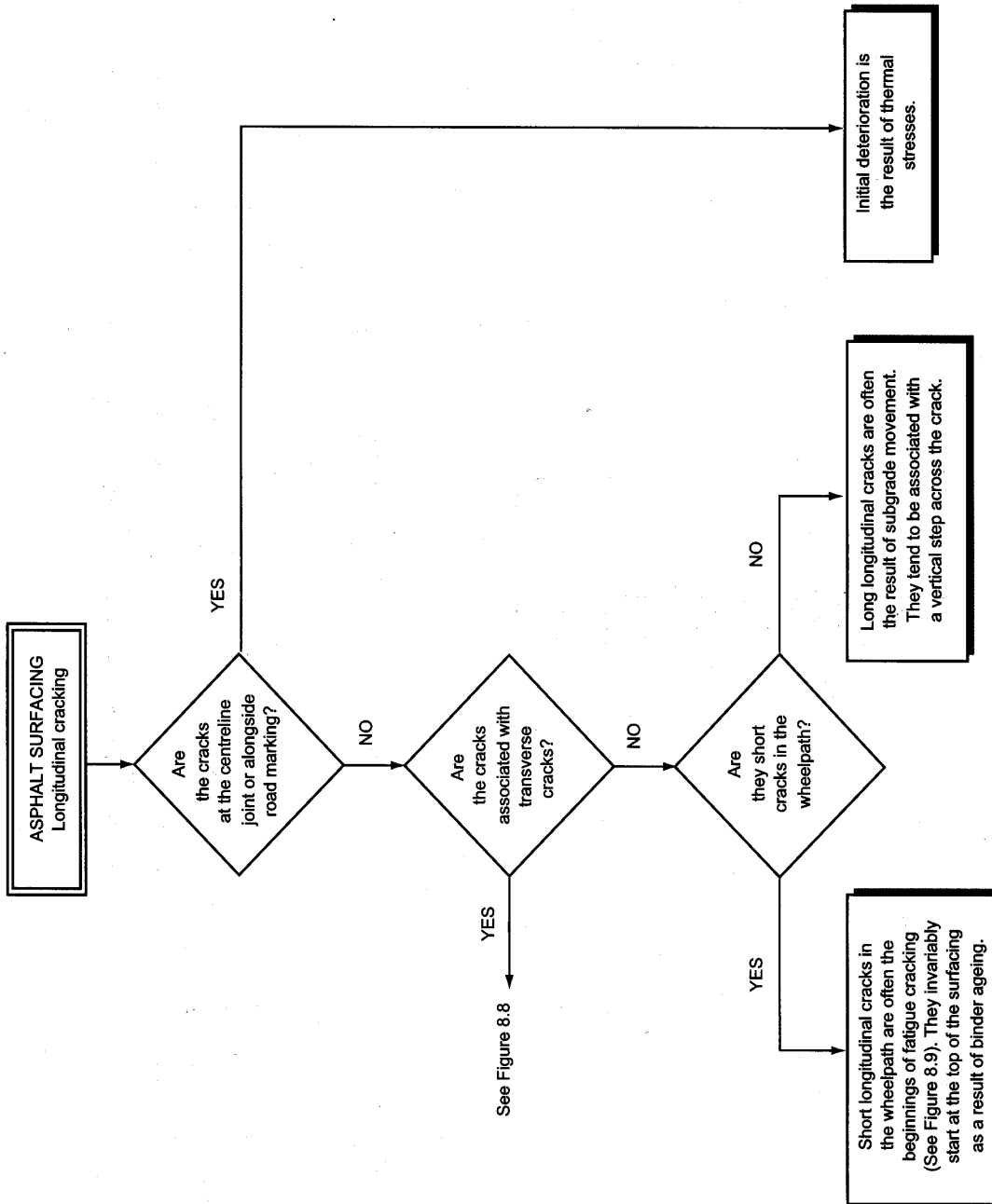

Figure 8.6 Initial deterioration - Longitudinal cracking in asphalt surfacing

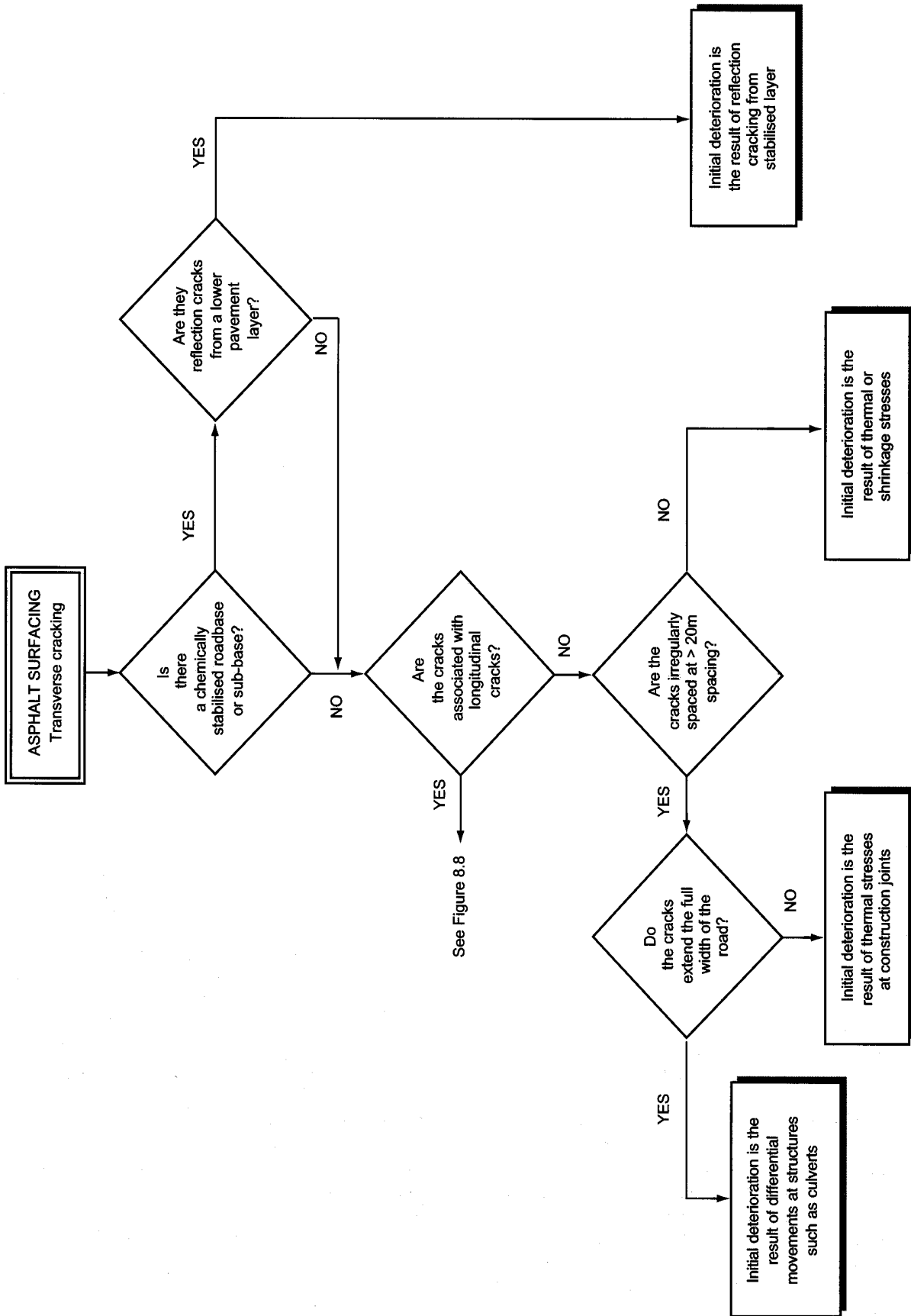

Figure 8.7 Initial deterioration - Transverse cracking in asphalt surfacing

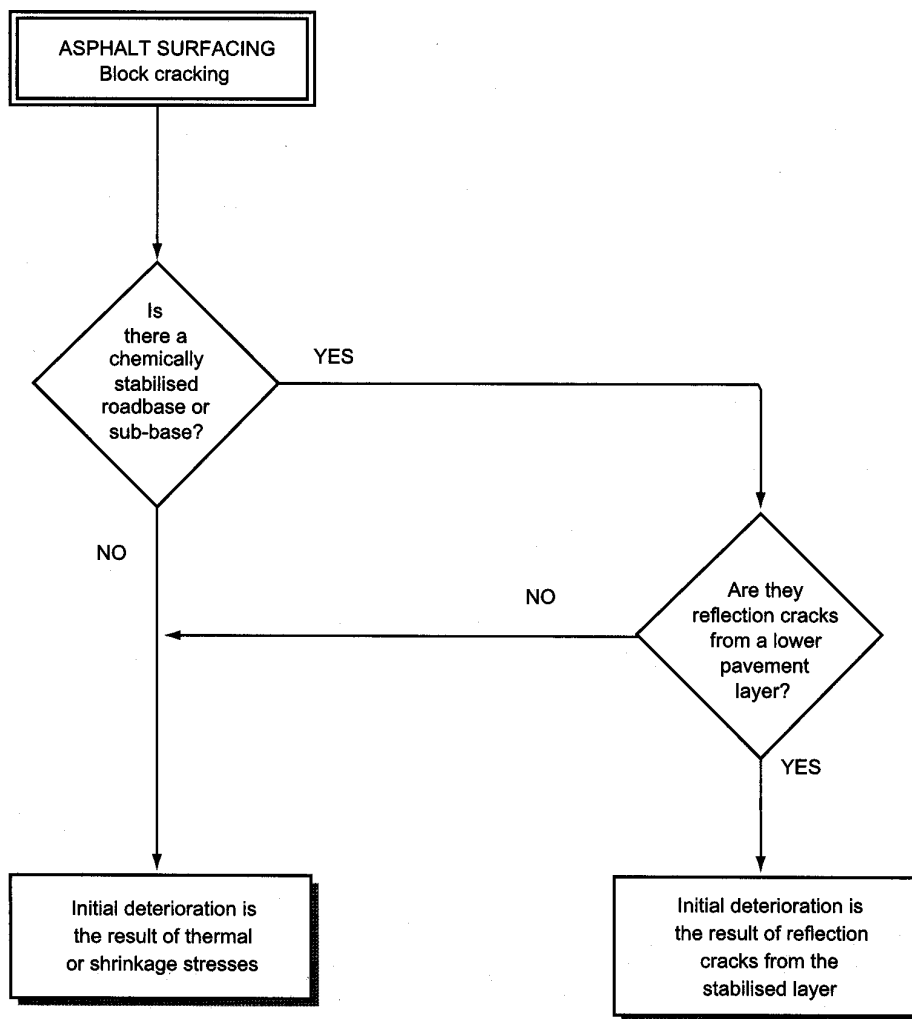

Figure 8.8 Initial deterioration - Block cracking in asphalt surfacing

propagate upwards. In tropical climates the bitumen at the top of asphalt wearing courses oxidises rapidly (Smith et al, 1990). This causes the material to become brittle and results in cracking being initiated at the top of the surfacing rather than at the bottom, despite the strains being lower (Rolt et al, 1986).

8.11 Where crocodile cracks are shown, by coring, to have started at the bottom of the asphalt layer, then they are likely to be 'traditional' fatigue cracks caused by excessive strains at the bottom of the surfacing. Excessive strains can be caused by a weak subgrade, giving rise to large maximum deflections, or a weak roadbase leading to small radii of curvature. However, in both cases the cracking is frequently associated with rutting; in the former case, because of insufficient load spreading; in the latter case, because of shear failure in the roadbase (see paras 8.5 and 8.7). In practice this type of crocodile cracking very rarely occurs without any rutting.

8.12 In some circumstances traditional fatigue cracking can occur simply because the road has

reached the end of its design life; in other words no other form of failure has occurred beforehand. This is a relatively rare phenomenon and for this reason is sometimes difficult to identify because of the need to calibrate standard asphalt fatigue relationships for local conditions. However, the age of the surfacing and the traffic carried should provide the most important clues.

8.13 Poor surfacing materials can also result in crocodile cracking. Inadequate quality control exercised during the manufacture and construction of dense surfacings can lead to poor particle size distribution, low bitumen contents, segregation and poor compaction, all of which will make the material more susceptible to cracking. Failures of this type can occur in areas where deflections are satisfactory and where little or no rutting is occurring

8.14 If the bond between the asphalt surfacing and the underlying layer is poor then the surfacing can effectively 'bounce' under traffic. This quickly results in crocodile cracking in the wheelpaths and is

characterised by blocks of less than 200mm square. The cause of the poor bond can be ineffective priming of the roadbase, or deficient tack coat prior to placing an overlay. Often the cracking will progress to laminations, which are shallow potholes that are clearly the result of the surfacing 'peeling' off.

8.15 Parabolic shaped cracks in the surfacing which occur in areas of severe braking such as the approaches to junctions and sharp bends are caused by slippage and are also the result of a poor bond. Small areas of parabolic cracking are not indicative of serious failure. However, if it is more extensive, the probable cause is an inadequate tack coat or the use of soft aggregate in the surfacing which, in breaking down, results in a poor bond and subsequent slippage.

8.16 Cracking in bituminous overlays, particularly in the wheelpaths, can be caused by cracks in the underlying layer 'reflecting' through the overlay. Reflection cracking will generally occur early in the life of the overlay and is often associated with pumping of fine material from a lower granular layer. Cores cut through cracks in the new overlay will establish whether they are being caused by existing cracks in a lower pavement layer.

Wheelpath cracking - thin bituminous seal (Figure 8.4)

8.17 The bitumen film in surface dressings is very thick compared to that in asphalt surfacings and it is more tolerant to flexure under traffic. Errors in the design or construction of these seals are more likely to result in failures such as bleeding or loss of stone rather than cracking. However, as the seal gets older, age hardening of the bitumen can result in wheelpath cracking or fretting. If cracking is being caused by excessive flexure under traffic then it will be associated with areas of high deflections.

8.18 Where the surfacing has been used to seal an existing cracked asphalt layer, any subsequent cracking may be caused by the reflection of cracks from the previous surfacing. Slurry seals are particularly susceptible to reflection cracking.

8.19 Bituminous seals having a poor bond with the underlying roadbase will behave in a similar way to that of an asphalt surfacing. In this case any water going through the resultant cracking will aggravate the poor bond, resulting in the rapid formation of potholes. This can be a problem with stabilised roadbases if they are not primed effectively prior to surfacing.

Non-wheelpath cracking - asphalt surfacing (Figure 8.5)

8.20 The cause of non-traffic associated cracking in an asphalt surfacing is largely established by identifying its type (see para 4.14). As traffic has

played little or no part in these road failures the cracks will not be confined to the wheelpaths and there will not be any substantial rutting. Non-wheelpath cracking can take the form of longitudinal, transverse, block or crocodile cracking.

Longitudinal cracking (Figure 8.6)

8.21 Thermal stresses can cause cracks to appear along poor longitudinal construction joints and in areas of severe temperature gradients, such as the edge of road markings. In their early stages neither of these types of crack is particularly serious; however, if left unsealed, the cracks will eventually spread into the wheelpaths where they will result in more serious deterioration.

8.22 Where longitudinal and transverse cracks occur in combination, they are likely to be either reflection cracks propagating from a lower stabilised layer or cracks caused by thermal or shrinkage stresses in the asphalt. These are described in more detail paragraphs 8.24 and 8.26.

8.23 Longitudinal cracks caused by subgrade movement will generally be quite long and can meander across the carriageway. They can occur because of poor construction, swelling in plastic subgrade or embankment materials, and the settlement or collapse of embankments. Cracks caused by the slippage of an embankment will often occur in semicircular patterns and both these and cracks caused by subgrade movement will often be associated with a vertical displacement across the crack.

Transverse cracking (Figure 8.7)

8.24 Transverse cracks in the surfacing of a road pavement which includes either a chemically stabilised roadbase or sub-base are likely to be reflection cracks from the stabilised layer, particularly if the stabiliser is cement. This form of transverse cracking is often associated with longitudinal cracks and, in severe cases, block cracking.

8.25 If the transverse cracks are irregularly or widely spaced they are likely to have been caused by some form of construction fault. Differential vertical movement caused by consolidation or secondary compaction adjacent to road structures and culverts can cause transverse cracks in the surfacing. These cracks will be associated with a poor longitudinal road profile caused by the differential movement.

8.26 Transverse cracks confined to the surfacing and occurring at more regular and shorter spacings are probably caused by thermal or shrinkage stresses. This type of cracking will most likely occur in areas subject to high diurnal temperature changes, such as desert regions, and will be exacerbated by poor quality surfacing materials. When cracks occur after

many years of good performance it is likely that progressive hardening of the binder has made the surfacing more 'brittle' and therefore more susceptible to cracking. As transverse thermal cracks progress, they will link up with longitudinal ones to form block cracking as shown in Figure 8.9. Thermal stresses can also cause cracks to open up at transverse construction joints.

Block cracking (Figure 8.8)

8.27 Block cracking, when confined to the bituminous surfacing, is usually the final stage of cracking due to thermal stresses. These cracks almost always start at the top of the surfacing and propagate downwards. Block cracking can also occur through reflection of the shrinkage crack pattern in lower chemically stabilised layers.

Crocodile cracking

8.28 Crocodile cracking that is neither confined to the wheelpaths nor associated with rutting is indicative of a fault in the construction of the surfacing. The more common production faults are poor particle size distribution, low binder contents, overheated bitumen and the use of absorptive aggregate. Construction faults include poor compaction, segregation of the mix and poor bonding, either between layers of bituminous material or the granular layer beneath. In these cases the precise cause of failure can only be determined by destructive sampling and laboratory testing.

Non-wheelpath cracking - thin bituminous seal

8.29 Roads having thin bituminous seals are less susceptible to the non-traffic associated failures described in paragraphs 8.21-8.28 because their thicker bitumen film results in a higher strain tolerance. Surface dressings, in particular, are less likely to crack either at construction joints or alongside road markings. They are also less susceptible to thermal or shrinkage cracking. Where strains are large, however, as in the case of reflection cracking from a stabilised roadbase or from subgrade movement, the surfacing failure will be similar to that described for asphalt surfacings.

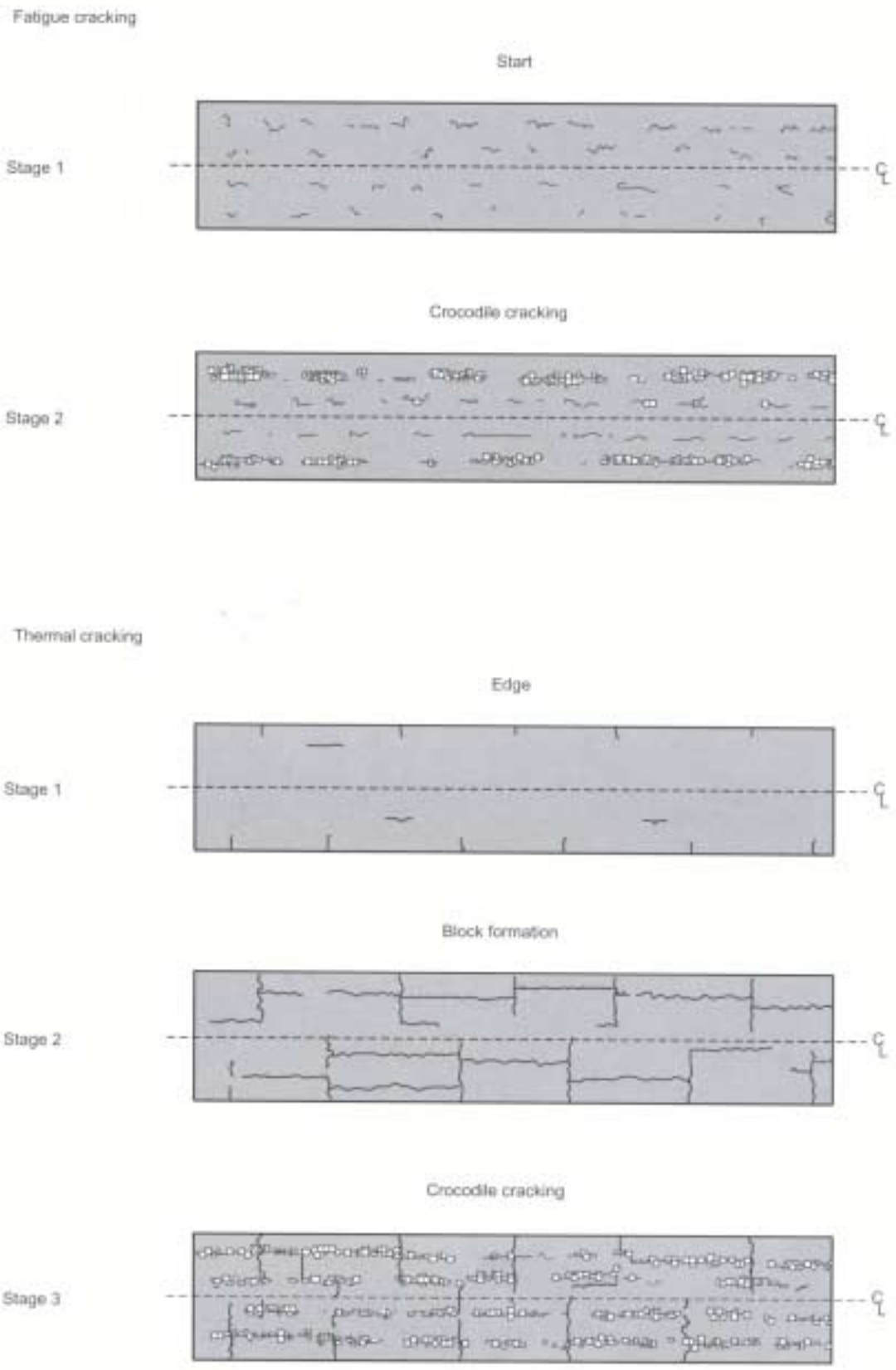

Figure 8.9 Crack development patterns in bituminous surfacings (after Dickinson, 1984)

9 Maintenance and rehabilitation

9.1 The selection of an appropriate maintenance treatment or rehabilitation strategy is based on a number of considerations. Firstly, the cause of deterioration in the existing pavement must be correctly identified and its importance assessed. For example, the deterioration may result from some deep seated structural insufficiency or construction defect. In such cases consideration must be given to full or partial reconstruction of the pavement to correct the situation. Secondly, attention should be given to the nature, extent and severity of the deterioration to check what effect it will have on the treatments that are being considered. For example, thin asphalt surfacings on their own will not provide a satisfactory repair where reflection cracking is likely, nor will any form of thin surfacing provide a significant improvement to riding quality where this is poor. Finally, the strategy must be economically viable taking into consideration both the costs of maintenance and the vehicle operating costs over a number of years.

9.2 It should not be assumed that when a road is in poor condition it inevitably needs strengthening. When traffic is low, for instance, the existing road structure is often thick enough to prevent long term rutting. In this case the maintenance treatment selected should address the cause, or causes, of the deterioration without necessarily adding strength to the pavement. It is important, therefore, to check the ability of the existing road pavement to carry the predicted traffic loading using at least two of the methods described below. Where either of the methods are shown to accurately predict the present performance of the road under study then the method is equally applicable for the design of strengthening works in the event that the road is shown to be too weak to carry the future traffic.

Analytical approach

9.3 The traffic carrying capacity of an asphalt pavement is governed by how effective the pavement layers are in preventing;

- fatigue cracking of the asphalt surfacing;
- shear failure of the granular materials;
- fatigue cracking or crushing of lightly cemented materials; and
- wheelpath rutting resulting from subgrade failure.

9.4 Theoretical models to predict the behaviour of granular and lightly cemented materials under the action of traffic are not well defined and therefore specifications for such layers have always been set in such a way that failures are unlikely. This has mitigated against the use of lower quality materials and has theoretically restricted the range of likely

failure modes. The performance of road pavements has traditionally been dependent on the stress/strain values at two locations in the structure. The horizontal tensile strain at the bottom of the asphalt layer controls one type of fatigue cracking and the vertical compressive strain at the top of the subgrade controls rutting.

9.5 For roads having a thin bituminous seal the traffic carrying capacity is determined only by resistance to rutting. The performance of the surface seal will generally depend on environmental effects rather than traffic loads. The traffic carrying capacity of an asphalt surfaced road will be determined by both its resistance to fatigue cracking and wheelpath rutting. However, research has shown that the predominant form of surface distress of asphalt surfacings in tropical climates is not fatigue cracking starting at the bottom of the asphalt layer but 'top-down' cracking which is initiated at the surface of the layer (Rolt et al, 1986) (Smith et al, 1990). The type and severity of this form of cracking is a complex function of material properties and both environmental and traffic stresses and its development has yet to be successfully described by means of a practical analytical model. 'Top-down' cracks often develop long before other types of cracks and thus the performance of asphalt surfaced roads rarely agrees with the analytical models. Nevertheless rehabilitation design should take account of all possible modes of future failure and therefore it is important to ensure that traditional fatigue failure of the surfacing and failure through inadequate protection of the subgrade do not occur within the design life required. In order to do this, analytical procedures properly calibrated to local conditions provide a suitable method.

9.6 The analytical approach requires a suitable mathematical model to describe the pavement. Almost all methods make use of the multilayer linear elastic model, although more sophisticated models can also be used. This model requires, as input, the thickness, elastic modulus and Poisson's ratio of each layer of the pavement. Very thin layers such as an existing seal are normally incorporated with the underlying roadbase or ignored. Asphalt surfacings are usually assigned moduli based on mix constituents and binder properties at the design temperature although direct laboratory measurements of modulus can also be made on samples of material extracted from the road. Other moduli values can be either calculated from the back-analysis of FWD deflection bowls or assigned values following DCP testing and/or the laboratory testing of samples taken from trial pits. Stresses or strains at the critical points in the pavement are then calculated under the application of a standard load designed to replicate a 40kN wheel load (80kN axle load). These strains are then used to calculate the 'life' of the structure using

relationships (Powell et al, 1984)(Shell, 1985) between stress/strain and pavement life of the form:

Asphalt fatigue criteria

$$\text{Log } N_f = a + b \text{ Log } \epsilon_r$$

Where N_f = Fatigue life in esa

ϵ_r = Horizontal tensile strain at the bottom of the asphalt layer

a and b = constants associated with material properties

Subgrade deformation criteria

$$\text{Log } N_d = a + b \text{ Log } \epsilon_z$$

Where N_d = Deformation life in esa

ϵ_z = Vertical compressive strain at the top of the subgrade

a and b = constants associated with material properties

9.7 Where the forms of these relationships are shown to predict the present performance of the road pavement, they can be used with more confidence to estimate the future traffic carrying capacity. After adjustment of the pavement model they can then also be used to determine overlay thickness, where necessary.

Structural approach

9.8 In this method the traffic carrying capacity of the road is estimated by comparing the existing pavement structure and its condition with established design charts. The thickness of the various pavement layers should first be established using the DCP and trial pits, and the in situ strength of the pavement layers and the subgrade determined by a combination of deflection and DCP data. These tests should be carried out shortly after the wettest period of the year, when the pavement can be expected to be in its weakest condition. If this is not possible, adjustments will need to be made to the deflection data and material properties to reflect the season during which the data were collected. The in situ strengths of the pavement layers obtained in this way, in particular the upper granular layers, should always be verified by laboratory tests to ensure they conform to normally accepted specifications. The effective structural number of the pavement can then be obtained by using techniques described in the AASHTO Guide for Design of Pavement Structures (AASHTO, 1993).

9.9 The required strengthening measures are then established by comparing the effective structural number of the pavement with the required structural number of a pavement for the future traffic, obtained from an appropriate design method, at a representative value of in situ subgrade strength. If

the AASHTO guide is used then a mean value of the resilient modulus of the subgrade, suitably corrected (AASHTO, 1993), is used. If Road Note 31 is preferred then the lower 10 percentile of the in situ subgrade CBR should be used, measured when the pavement is in its weakest condition. Where the comparison of the effective structural number, past traffic and design recommendations is shown to be consistent with the present condition of the road pavement, then the engineer can be more confident in designing the thickness of any necessary strengthening overlay by this method.

9.10 There are presently a number of methods of determining the structural number of a road pavement directly from FWD deflection bowl characteristics (AASHTO, 1993) (Jameson, 1992) (Rohde, 1994) (Roberts and Martin, 1996). With the development and refinement of these procedures it is likely that the rehabilitation of road pavements using the structural number approach will become increasingly popular.

Deflection approach

9.11 The representative maximum deflection is used by a number of road authorities to estimate the carrying capacity of a road (Kennedy and Lister, 1978) (Asphalt Institute, 1983). The deflection criteria curves recommended in these design procedures (i.e. the relationship between deflection and traffic carrying capacity) are not necessarily applicable to road pavements found in tropical and sub-tropical regions. However, it is clear that an overlay reduces the stresses in the lower layers of the pavement and therefore, to prevent deformation in these layers and the subgrade, appropriate deflection criteria can be developed (NITRR, 1983). Such an approach is particularly appropriate when investigations show that either the project road, or other roads of similar construction in the region, are rutting because of a deficiency in the overall 'strength' of the pavement (see para 7.4).

9.12 The deflection and condition surveys must be carried out after the wettest period of the year when the road pavement can be expected to be at its weakest. The severity of rutting is then plotted against the maximum deflection at each test point and a best fit line and confidence limits calculated as shown in Figure 9.1. The value of critical deflection corresponding to a defined level of critical rutting is then determined for any particular level of statistical reliability. The 90th percentile is recommended with a critical rut depth of 10mm for roads with asphalt surfacings and 15mm for those with thin bituminous seals. Provided the past traffic loading is known, one point can be plotted on the deflection traffic-loading graph. This point is unlikely to lie on an existing criteria curve, however, assuming a similar form of relationship, a 'calibrated criteria curve' can be obtained by drawing a new line through the point and parallel to the existing curve as illustrated.

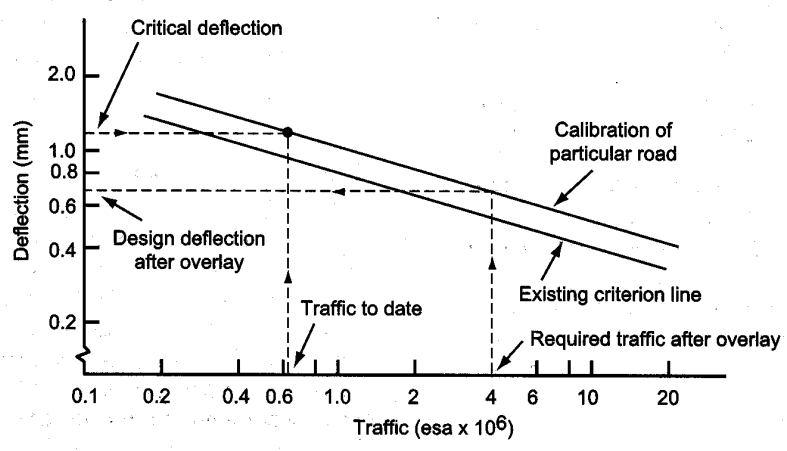
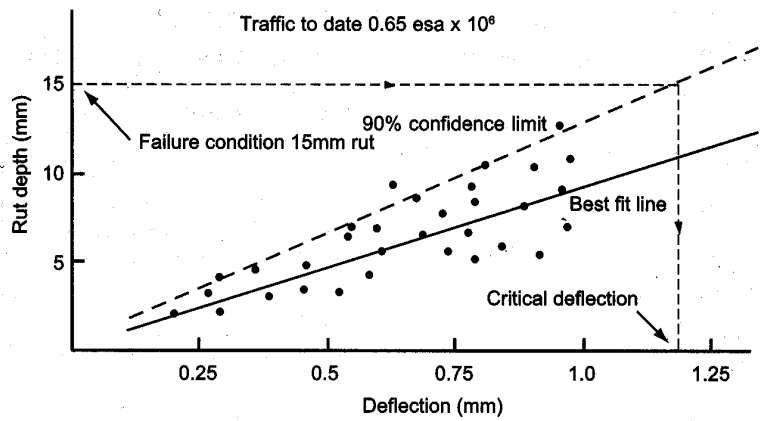

Figure 9.1 Diagrammatic calibration of deflection life criterion line (after NITRR, 1983)

9.13 The traffic carrying capacity of the road, in terms of rutting, can be estimated by comparing the representative deflection of homogeneous sections (see Appendix D) with the calibrated deflection criteria curve as shown in Figure 9.1. The traffic carrying capacity represents the total traffic loading that the road will carry from construction. Therefore the future traffic carrying capacity is the total traffic loading minus the traffic loading that the pavement has earned prior to evaluation.

9.14 The thickness of any necessary strengthening overlay can be determined based on reducing the representative deflection of the pavement to the design deflection obtained from the calibrated deflection curve. The relation between the thickness of a dense bituminous overlay and the reduction in deflection, under a 62.3kN axle load, has been shown to be:

$$T = \frac{0.036 + 0.818 D_r - D_d}{0.0027 D_r} \quad (3)$$

where D_d = Design deflection (mm)
 D_r = Representative deflection (mm)
 T = Overlay thickness (mm)

This relation is valid between representative deflection values of 0.25 - 1.2mm and overlay thicknesses of 40 - 150mm.

Maintenance options

9.15 If it is established that the road does not require strengthening, the method of maintenance should be based upon the type of the existing surfacing and the cause of failure. Pavement maintenance will generally result in two operations. Firstly, those areas where failure has already occurred should be repaired by some form of remedial treatment and, secondly, the road should generally be resurfaced to prevent other lengths failing in a similar manner. Suggested methods of maintenance for the different types of pavement deterioration for roads having thin bituminous seals and asphalt surfacings are given in Tables 10 and 11 respectively.

Reflection cracking

9.16 Reflection cracking can have a considerable and often controlling influence on the life of thin bituminous overlays. The rate of propagation of these cracks has been shown to be dependent on the strength of the road, the severity of the cracking before overlay and the future traffic (Rolt et al, 1996). The complete prevention of reflection cracking through thin overlays is not possible. However, when the existing cracked asphalt surface is relatively thin, the most effective method of reducing reflection cracking in any subsequent overlay is to remove the areas showing cracking of intensity 3 or greater and to patch prior to construction. Where the existing surfacing consists of several previous bituminous overlays, it may be more cost effective to introduce a crack relief interlayer rather than to remove all the cracked material. Reviews of practice in North America (Sherman, 1982)(Barksdale, 1991) suggest that the most successful techniques are:

- asphalt-rubber interlayers;
- interlayers of open-graded bituminous material; or
- heater-scarification and recompaction of the cracked layer.

Table 10 Existing road surface - Thin bituminous seal

<i>Primary failure</i>	<i>Remedial treatment</i>	<i>New surfacing</i>	<i>Comments</i>
Surface defects			
Fretting	Local patching	Surface dressing or slurry seal	
Fatting-up		Surface dressing (See Note 1)	Where texture depth has decreased to an unacceptable level.
Bleeding or loss of stone	Burn off excess binder	Surface dressing (See Note 1)	
	Apply heated aggregate		Where failures are localised.
Loss of texture		Surface dressing	
Polished aggregate		Surface dressing or slurry seal	Use aggregate with suitable Polished Stone Value for expected traffic (See Note 2).
Rutting without shoving (Figure 8.1)			
Secondary compaction		Thin overlay	
Excessive traffic loading or inadequate pavement thickness		Regulating layer followed by a strengthening overlay	
Rutting with shoving (Figure 8.2)			
Excessive wheel loads	Remove surfacing and replace or modify existing roadbase	Double surface dressing	Existing roadbase may be suitable for stabilisation with cement.
	Add bituminous roadbase	Double surface dressing	Check existing roadbase is suitable for sub-base.
Inadequate roadbase			
Too thin	Remove surfacing and increase roadbase thickness with granular overlay	Double surface dressing	
Too weak	Remove surfacing and replace or modify existing roadbase	Double surface dressing	Existing roadbase may be suitable for mechanical stabilisation or modification with lime or cement.
	Remove surfacing and construct new roadbase	Double surface dressing	Check that existing roadbase is suitable to be reworked for a sub-base.
Inadequate sub-base			
Too weak	—	—	Regard sub-base as subgrade and re-design pavement accordingly.
Wheelpath cracking (Figure 8.4)			
Poor bond	Remove surfacing where the bond is poor and patch		
Excessive flexure exacerbated by age hardening of the binder	Remove areas of cracking of intensity 4 or greater and patch. Chase out any cracks more than 3mm wide and seal with proprietary crack sealant.	Surface dressing (See Note 3)	Check whether road needs strengthening.

Table 10 (Continued)

<i>Primary failure</i>	<i>Remedial treatment</i>	<i>New surfacing</i>	<i>Comments</i>
Reflection cracking	Remove areas of cracking of intensity 4 or greater and patch. Chase out any cracks more than 3mm wide and seal with proprietary crack sealant.	Surface dressing (See Note 3)	
<i>Non-wheelpath cracking (para 8.29)</i>			
Reflection cracking	Chase out any cracks more than 3mm wide and seal with proprietary crack sealant.	Surface dressing if reflection cracking has extent greater than 1 (See Note 3)	
Subgrade movement	Immediately chase out and seal all cracks to prevent the ingress of water.		Pavement should be sealed with a double surface dressing after crack development has stabilised (See Note 3).

1 The design of the new seal must account for the hardness of the existing surface (TRRL, 1982).

2 Minimum Polished Stone Values are specified elsewhere (Department of Transport, 1994a)

3 Some organisations (Queensland Transport, 1992) have shown that the inclusion of fabrics improves the performance of surface dressings. However, it is recommended that initially these techniques be introduced on a pilot scale basis to ensure contractors are trained in the techniques.

Table 11 Existing road surface - Asphalt surfacing

<i>Primary failure</i>	<i>Remedial treatment</i>	<i>New surfacing</i>	<i>Comments</i>
Surface defects			
Fretting or stripping	Local patching	Surface dressing or slurry seal	
Fatting-up		Surface dressing	Where texture depth has decreased to an unacceptable level.
Bleeding	Remove surfacing	Asphalt surfacing	Asphalt surfacings that are bleeding will rapidly deform and may need to be removed.
	Apply heated fine aggregate		Where failures are localised.
Loss of texture		Surface dressing	
Polished aggregate		Surface dressing or slurry seal	Use aggregate having suitable Polished Stone Value for the expected traffic (See Note 2).
Rutting without shoving (Figure 8.1)			
Secondary compaction		Thin overlay	
Excessive traffic loading or inadequate pavement thickness	Reflection crack treatment if necessary (See para 9.16)	Regulating layer followed by strengthening overlay	
Rutting with shoving (Figure 8.2)			
Inappropriate surfacing material	Remove surfacing that has failed	Replace with new asphalt surfacing material	(See Note 1)
Surfacing out of specification	Remove surfacing that has failed	Replace with new asphalt surfacing material	
Inadequate roadbase			
Too thin	Remove surfacing and increase thickness of roadbase with a granular overlay.	Asphalt surfacing	
Too weak	Remove surfacing. Replace or modify existing roadbase.	Asphalt surfacing	Existing roadbase may be suitable for mechanical stabilisation or modification with lime or cement.
Wheelpath cracking (Figure 8.3)			
Isolated slippage	Remove affected surfacing and patch		
Extensive slippage	Remove surfacing and replace	Asphalt surfacing	
Cracks confined to the top of the surfacing		Double surface dressing (See Note 3)	
Poor bond	Remove affected surfacing and patch		Where the failures are extensive the surfacing will need to be removed and the road resurfaced with asphalt.
Poor surfacing material	Remove areas of cracking of intensity 3 or greater and patch. Chase out cracks more than 3mm wide and seal with proprietary crack sealant.	Double surface dressing or asphalt surfacing (See Note 3)	Where the failures are extensive the surfacing will need to be removed and the road resurfaced with asphalt.

Table 11 (Continued)

<i>Primary failure</i>	<i>Remedial treatment</i>	<i>New surfacing</i>	<i>Comments</i>
Fatigue cracking	Remove areas of cracking of intensity 3 or greater and patch. Chase out cracks more than 3mm wide and seal with proprietary crack sealant.	Double surface dressing or asphalt surfacing (See Note 3)	Where the failures are extensive check whether the road needs strengthening.
Reflection cracking	Remove areas of cracking of intensity 3 or greater and patch. Chase out cracks more than 3mm wide and seal with proprietary crack sealant.	Double surface dressing or asphalt surfacing (See Note 3)	If a crack relief interlayer is to be used under an asphalt surfacing then areas of crack intensity 4 or greater should be removed and patched.
<i>Non-wheelpath cracking (Figures 8.5 to 8.8)</i>			
<i>Longitudinal cracks</i>			
i) At construction joints and road markings	Chase out cracks and seal with proprietary crack sealant.		
ii) Subgrade movement	Immediately chase out and seal all cracks with proprietary crack sealant to prevent the ingress of water.		Pavement should be sealed with a double surface dressing after the crack development has stabilised (See Note 3).
iii) Reflection cracks	Chase out cracks more than 3mm wide and seal with proprietary crack sealant.	Double surface dressing if reflection cracking has an extent greater than 1 (See Note 3).	
<i>Transverse cracks</i>			
i) At construction joints and structures	Chase out cracks and seal with proprietary crack sealant.		
ii) Thermal or shrinkage cracks	Chase out cracks more than 3mm wide and seal with proprietary crack sealant.	Double surface dressing (See Note 3)	
iii) Reflection cracks	Chase out cracks more than 3mm wide and seal with proprietary crack sealant.	Double surface dressing if reflection cracking has an extent greater than 1 (See Note 3).	
<i>Block cracking</i>			
i) Thermal or shrinkage cracks	Chase out cracks more than 3mm wide and seal with proprietary crack sealant.	Double surface dressing (See Note 3)	If block cracking is severe then the surfacing will need to be removed and replaced.
ii) Reflection cracks	Chase out cracks more than 3mm wide and seal with proprietary crack sealant.	Double surface dressing if reflection cracking has an extent greater than 1 (See Note 3).	If block cracking is severe then the surfacing will need to be removed and replaced.
Crocodile cracking	Remove surfacing	Asphalt surfacing	

1 Road Note 31 includes a mix design procedure for bituminous surfacings suitable for severe loading conditions. Many authorities also use bitumen modifiers for asphalt surfacings subject to severe loading.

2 Minimum Polished Stone Values are specified elsewhere (Department of Transport, 1994a)

3 Some organisations (Queensland Transport, 1992) have shown that the inclusion of fabrics improves the performance of surface dressings. However, it is recommended that initially these techniques be introduced on a pilot scale basis to ensure contractors are trained in the techniques.

10 References

- AASHTO (1993).** *Design of pavement structures.* American Association of State Highway and Transportation Officials, Washington DC.
- Asphalt Institute (1983).** *Asphalt overlays for highway and street rehabilitation.* Manual Series No. 17 (MS-17). Asphalt Institute, Lexington.
- ARRB (1996).** *Walking Profilometer.* ARRB Transport Research Ltd, Victoria.
- Austrroads (1992).** *Pavement design.* A guide to the structural design of road pavements. Austrroads, Sydney.
- Barkdale R D (1991).** *Fabrics in asphalt overlays and pavement maintenance.* Synthesis of Highway Practice 171. Transportation Research Board, Washington DC.
- Beaven P J and Tubey L W (1978).** *The polishing of roadstone in Peninsular Malaysia.* Supplementary Report SR 421. Transport Research Laboratory, Crowthorne.
- Bertrand C, Harrison R and Hudson W R (1991).** *Evaluation of a high-resolution profiling instrument for rise in road roughness calibration.* Transportation Research Record 1291, Transportation Research Board, Washington DC.
- Chesher A D and Harrison R (1987).** *Vehicle operating costs: evidence from developing countries.* Highway Design and Maintenance Standards Series. The John Hopkins University Press, Maryland.
- Committee of State Road Authorities (1992).** *Pavement management systems: Standard visual assessment manual for flexible pavements.* Technical Methods for Highways TMH No 9. Committee for State Road Authorities, Pretoria.
- County Surveyors Society (1988).** *A directory of pavement assessment equipment.* County Surveyors Report No 5/10. Devon County Council.
- Cundill M A (1996).** *The MERLIN road roughness machine: User guide.* TRL Report TRL229. Transport Research Laboratory, Crowthorne.
- Department of Transport (1994a).** *Skidding resistance.* Design Manual for Roads and Bridges, Volume 7: Sect 3: Part 1: HD 28/94. Department of Transport, UK.
- Department of Transport (1994b).** *Structural assessment methods.* Design Manual for Roads and Bridges, Volume 7: Sect 3: Part 2: HD 29/94. Department of Transport, UK.
- Dickinson E J (1984).** *Bituminous roads in Australia.* Australian Road Research Board.
- Hide H S, Abaynayaka S W, Sayer I and Wyatt R J (1974).** *The Kenya road transport cost study: research on vehicle operating costs.* Laboratory Report LR 672. Transport Research Laboratory, Crowthorne.
- Hodges J W, Rolt J and Jones T E (1975).** *The Kenya road transport cost study: research on road deterioration.* Laboratory Report LR 673. Transport Research Laboratory, Crowthorne.
- Jameson G W (1992).** *Development of the Philippines Asphalt Overlay Procedure.* Report for ADB Technical Assistance Project TA No. 1426 PHI. VicRoads, SMEC and Queensland Transport. (Asian Development Bank, Manila, Philippines).
- Jones C R and Smith H R (1980).** *Deflection temperature relationships for bituminous surfacings in Kenya.* Laboratory Report LR 936. Transport Research Laboratory, Crowthorne.
- Kennedy C K and Lister N W (1978).** *Prediction of pavement performance and the design of overlays.* Laboratory Report LR 833. Transport Research Laboratory, Crowthorne.
- Kleyn E G and Van Heerden (1983).** *Using DCP soundings to optimise pavement rehabilitation.* Annual Transportation Convention. Report LS/83 Materials Branch, Transvaal Roads Department, Pretoria.
- Livneh M, Ishai I and Livneh N A (1995).** *The effect of vertical confinement on the DCP strength values in pavement and subgrade evaluation.* Transportation Research Board, 74th Annual Meeting. Washington DC.
- Morosiuk G, Jones C R and Osman M (1992).** *Calibration and standardisation of road roughness measurements using the TRRL profile beam.* 7th Conf. of the Road Engineering Association of Asia and Australasia, Singapore.
- National Institute for Road Research (1970).** *The measurement of deflection and curvature of road surfaces.* CSIR Technical Guide K16. Council for Scientific and Industrial Research, Pretoria.
- National Institute for Transport and Road Research (1983).** *Bituminous pavement rehabilitation design. Draft Technical recommendations for Highways TRH 12.* Council for Scientific and Industrial Research, Pretoria.
- National Institute for Transport and Road Research (1985).** *Nomenclature and methods for describing the condition of asphalt pavements.* Technical Recommendations for Highways TRH No 6. Council for Scientific and Industrial Research, Pretoria.

Paterson W D O (1987). *Road deterioration and maintenance effects: models for planning and management.* Highway Design and Maintenance Series. The John Hopkins University Press, Baltimore, Maryland.

Powell W D, Potter J F, Mayhew H C and Nunn M E (1984). *The structural design of bituminous roads.* Laboratory Report LR 1132. Transport Research Laboratory, Crowthorne.

Queensland Transport (1992). *Pavement rehabilitation manual.* Pavements and Asset Strategy Branch, Queensland Transport, Queensland.

Road Research Laboratory (1969). *Instructions for using the portable skid resistance tester.* Road Note 27. Stationery Office, London.

Roberts J D and Martin T C (1996). *Recommendations for monitoring pavement performance.* Research Report ARR 293. ARRB Transport Research Ltd, Victoria.

Rohde G T (1994). *Determining pavement structural number from FWD testing.* Transportation Research Record 1448, Transportation Research Board, Washington DC.

Rolt J, Smith H R and Jones C R (1986). *The design and performance of bituminous overlays in tropical environments.* 2nd Conf. The Bearing Capacity of Roads and Airfields, Plymouth.

Rolt J, Hasim M S, Hameed M and Suffian Z (1996). *The prediction and treatment of reflection cracking in thin bituminous overlays.* Second Malaysian Road Conference 1996, Innovations in Road Building. Kuala Lumpur.

Sayers M W, Gillespie T D and Queroz C A V (1986a). *The international road roughness experiment: establishing correlation and a calibration standard for measurements.* Technical Paper No. 45. World Bank, Washington DC.

Sayers M W, Gillespie T D and Paterson W D O (1986b). *Guidelines for conducting and calibrating road roughness measurements.* Technical Paper No. 46. World Bank, Washington DC.

Shell (1985). *Addendum to the Shell pavement design manual.* Shell International Petroleum Co. Ltd., London.

Sherman G (1982). *Minimising reflection cracking of pavement overlays.* Synthesis of Highway Practice 92. Transportation Research Board, Washington DC.

Smith H R and Jones C R (1980). *Measurement of pavement deflections in tropical and sub-tropical climates.* Laboratory Report LR 935. Transport Research Laboratory, Crowthorne.

Smith H R, Rolt J and Wambura J (1990). *The durability of bituminous overlays and wearing courses in tropical environments.* 3rd Conf. The Bearing Capacity of Roads and Airfields. Trondheim.

Smith R B and Pratt D N (1983). *A field study of in situ California bearing ratio and dynamic cone penetrometer testing for subgrade investigations.* Australian Road Research 13(4) pp 285-294. Australian Road Research Board.

Strategic Highway Research Programme (1993a). *SHRP'S layer moduli backcalculation procedure.* SHRP-P-655. Strategic Highway Research Programme. National Research Council, Washington DC.

Strategic Highway Research Programme (1993b). *Falling weight deflectometer relative calibration analysis.* SHRP-P-652. Strategic Highway Research Programme. National Research Council, Washington DC.

Transport and Road Research Laboratory (1978). *A guide to the measurement of axle loads in developing countries using a portable weighbridge.* Road Note 40. Transport Research Laboratory, Crowthorne.

Transport and Road Research Laboratory (1982). *A guide to surface dressing in tropical and subtropical climates.* Overseas Road Note 3. Transport Research Laboratory, Crowthorne.

Transport and Road Research Laboratory (1985). *Maintenance techniques for district engineers.* Overseas Road Note 2, Transport Research Laboratory, Crowthorne.

Transport and Road Research Laboratory (1988). *A guide to road project appraisal.* Overseas Road Note 5, Transport Research Laboratory, Crowthorne.

Transport and Road Research Laboratory (1990). *A users manual for a program to analyse dynamic cone penetrometer data.* Overseas Road Note 8. Transport Research Laboratory, Crowthorne.

Transport and Road Research Laboratory (1993a). *The road transport investment model - User's Manual.* Overseas Centre, Transport Research Laboratory, Crowthorne.

Transport and Road Research Laboratory (1993b). *A guide to tile structural design of bitumen-surfaced roads in tropical and sub-tropical climates.* Overseas Road Note 31. Transport Research Laboratory, Crowthorne.

Van Vuuren (1969). *Rapid determination of CBR with the portable dynamic cone penetrometer.* The Rhodesian Engineer.

Watanatada T, Harral C G, Paterson W D O, Dhareshwar A M, Bhandari A and Tsunokawa K (1987). *The highway design and maintenance standards model.* Highway Design and Standards Series. The John Hopkins University Press, Maryland.

11 Applicable standards

The British Standards Institution is the independent national body for the preparation of British Standards. Enquiries should be addressed to BSI, Linford Wood, Milton Keynes, MK14 6LE.

BS 598 Sampling and examination of bituminous mixtures for roads and other paved areas

Part 100:1987 Methods for sampling for analysis

Part 105:1990 Methods of test for the determination of texture depth

BS 812 Sampling and testing of mineral aggregates, sands and fillers

Part 2:1975 Methods for determination of physical properties

Part 105:1990 Methods for determination of particle shape

Part 110:1990 Methods for determination of aggregate crushing value

Part 111:1990 Methods for determination of ten percent fines value

Part 112:1990 Methods for determination of aggregate impact value

Part 113:1990 Methods for determination of aggregate abrasion value

Part 121:1989 Method for determination of soundness

BS 1377 Soils for civil engineering purposes

Part 2:1990 Classification tests

Part 4:1990 Compaction-related tests

Part 8:1990 Shear strength tests (effective stress)

Part 9:1990 In-situ tests

The American Society for Testing and Materials is a not-for-profit organisation which provides a forum for producers, users, ultimate consumers and those having a general interest to meet on common ground and write standards for materials, products, systems and services. Enquiries should be addressed to ASTM, 100 Barr Harbor Drive, West Conshohocken, PA 19428-2959.

C 131-96 Test method for resistance to degradation of small-sized coarse aggregates by abrasion and impact in the Los Angeles machine

C 535-96 Test method for resistance to degradation of large-sized coarse aggregates by abrasion and impact in the Los Angeles machine

D 3319-90 Test method for accelerated polishing of aggregates using the British wheel

E 303-93 Test method for measuring surface frictional properties using the British pendulum tester

E 1364-95 Test method for measuring road roughness by static level method

Appendix A: Detailed surface condition survey

The detailed surface condition survey is a walking survey carried out by a team of four technicians/labourers and one support vehicle with driver. This team size should be able to complete 10 lane kilometres per day. Increasing output by surveying both lanes of a two lane highway simultaneously is not recommended.

A safe working environment should be maintained at all times. Many organisations will have on-site procedures which should be followed. Where there are no local safety procedures those described in Overseas Road Note 2 are recommended (TRRL, 1985).

The equipment needed by the team, after the road has been permanently marked, is:

- traffic control signs or flags;
- 2 metre straight-edge and wedge (Figure 4.5);
- crack width gauge (Figure 4.4);
- distance measurer; and
- surface condition forms (Figure 4.1) and a clipboard.

The results of the survey should be recorded on pre-printed forms as these provide a check list for the technician, telling him what items are to be examined during the inspection and so reducing the possibility that significant information is omitted.

Appendix B: Road roughness measurements

The many methods for measuring road roughness in use throughout the world can be grouped into four generic classes (Sayers et al, 1986b) on the basis of how accurately they measure the profile of the road and hence International Roughness Index (IRI).

- Class 1 - Precision profiles
- Class 2 - Other profilometric methods
- Class 3 - IRI by correlation
- Class 4 - Subjective ratings

Class 1 - Precision profiles

This class has the highest standard of accuracy. Class 1 methods are those which sample the vertical profile of the road at distances no greater than 250mm to an accuracy of 0.51mm for smooth roads. This profile is then used to directly compute the IRI. Class 1 methods are mainly used for the calibration and validation of other methods of roughness measurement. They can be used for relatively short sections where a high degree of accuracy is required but are not suitable for general roughness surveys. Examples of Class 1 methods include the rod and level survey (ASTM, E 1364-95), the TRL Profile Beam, the Face Dipstick (Bertrand et al, 1991) and the ARRB Walking Profiler (ARRB, 1996).

Class 2 - Other profilometric methods

This class includes all other methods in which the road profile is measured as the basis for direct computation of the IRI, but which are not capable of the accuracy and/or measurement interval specified for a Class 1 precision profile. This class includes most high-speed profilometers.

Class 3 - IRI from correlation

Devices in this class measure roughness but need calibration to convert the data into units of MI. The majority of road roughness data currently collected throughout the world are obtained with Response-Type Road Roughness Measuring Systems (RTRRMS). While these systems can take the form of towed trailers, such as the towed 5th wheel bump integrator, they more frequently involve instruments mounted in a survey vehicle. Examples of vehicle-mounted RTRRMS include the TRL bump integrator unit, the NAASRA meter and the Mays meter. These instruments usually measure roughness in terms of the cumulative movement between the vehicle's axle and chassis when travelling along a road under standard conditions.

Also in this class is a low cost alternative, the Machine for Evaluating Roughness using Low-cost Instrumentation (MERLIN) that can be used to both

estimate IRI and also calibrate other RTRRMS. The MERLIN does not record the absolute profile but measures the mid-chord deviations over a predetermined base length for a section of road (see Figure B 1) and then relates a statistic from the frequency of those deviations to the IRI using a predetermined correlation.

The roughness values recorded by RTRRMS depend on the dynamics of the vehicle and the speed at which it is driven. The dynamic properties of each vehicle are unique and will also change with time, for example as springs and shock absorbers wear. It is therefore essential that the roughness values obtained from a RTRRMS are converted to units of IRI by regularly calibrating it with a Class 1 or 2 device or the MERLIN.

Class 4 - Subjective rating

This class has the lowest standard of accuracy. It includes methods such as subjective evaluation involving rideability and visual assessment. This is illustrated in Figure B2. The estimate of IRI has been found to be subject to errors of up to 40 per cent for new observers (Sayers et al, 1986b) and therefore this method should only be used when other methods are unavailable. Uncalibrated RTRRMS also fall into this category.

Roughness surveys using a RTRRMS.

When roughness measurements are required on more than a few short sections of road, a RTRRMS is recommended. The main advantages of these types of systems are their relative low cost and the high speed of data collection. The systems are capable of surveys at speeds up to 80 km/h, so many hundreds of kilometres of road can be measured in a day.

The TRL Bump Integrator (BI) Unit is a response-type road roughness measuring device that is mounted in a vehicle. The instrument measures the roughness in terms of the cumulative uni-directional movement between the rear axle and the chassis of a vehicle in motion. The BI system comprises of a bump integrator unit, a counter unit with 2 displays, connection leads and an optional installation kit. The system is powered by the 12 volt battery of the vehicle.

Fitting the BI unit

The BI unit is mounted in a rear-wheel drive vehicle as shown diagrammatically in Figure B3. The unit is bolted to the rear floorpan of the vehicle directly above the centre of the rear axle. A 25mm hole needs to be cut in the floorpan and a bracket or hook fixed to the centre of the differential housing of the rear axle.

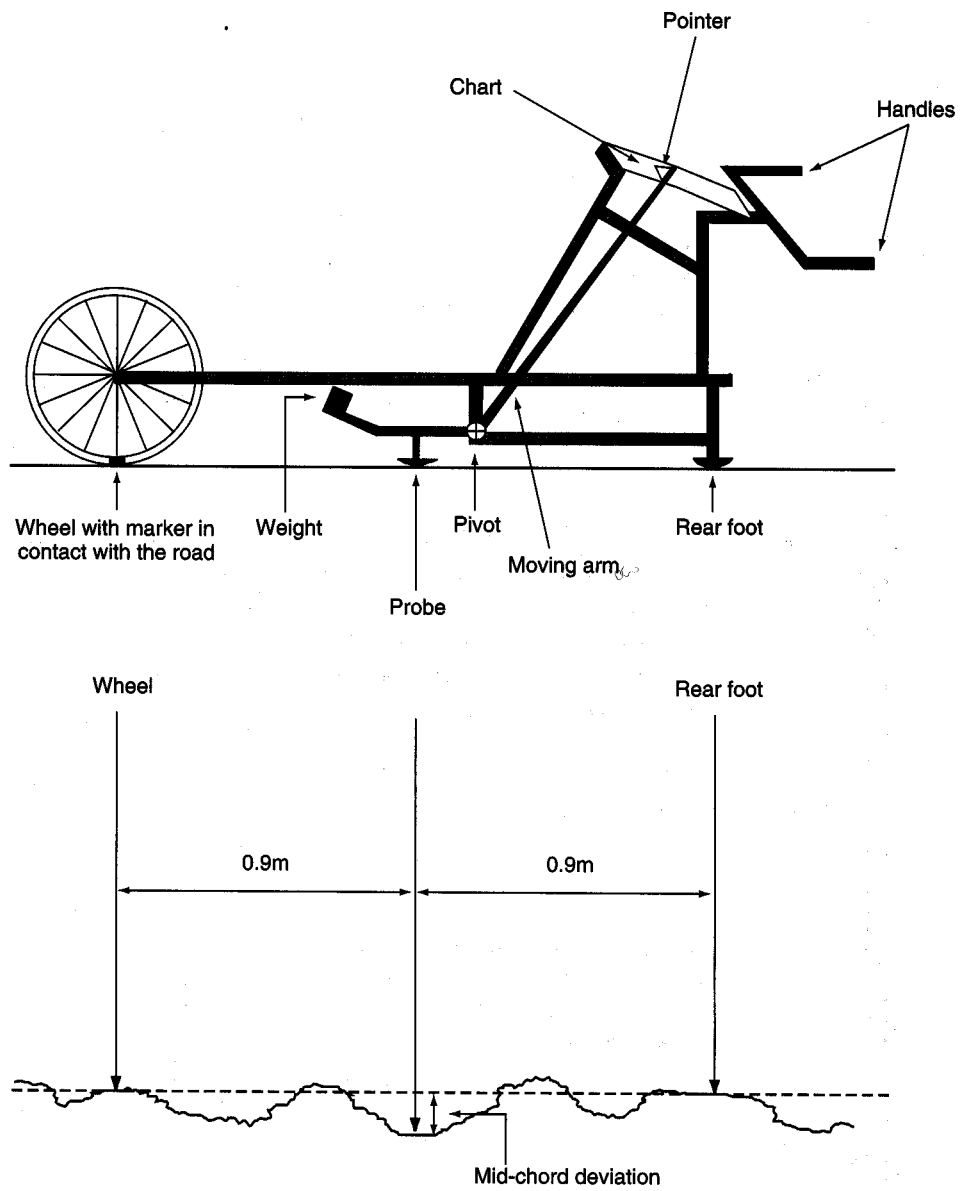

Figure B1 Operation of the MERLIN

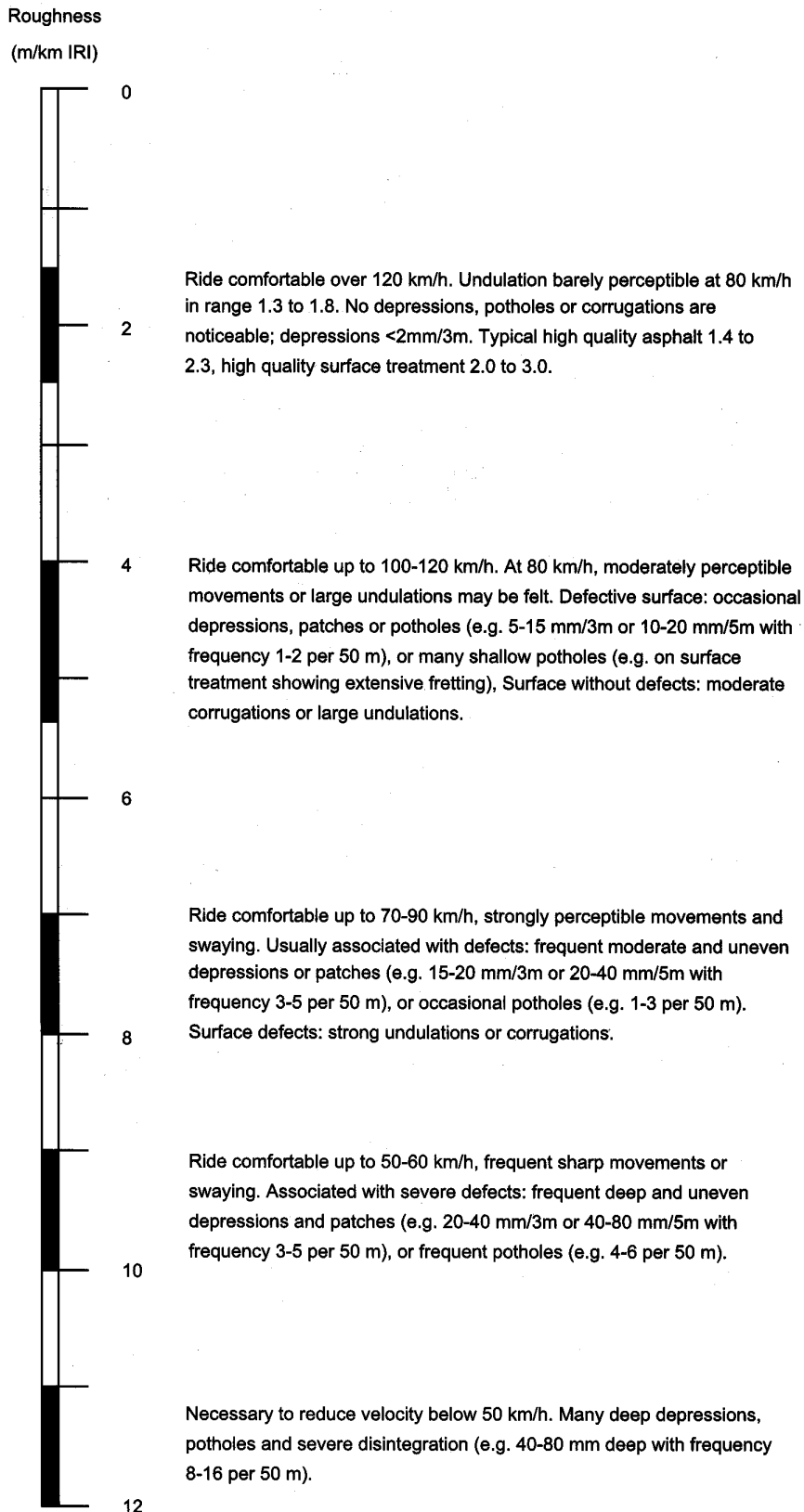

Figure B2 Road roughness estimation scale for paved roads with asphaltic concrete or surface dressed surfacings (after Sayers et al, 1986b)

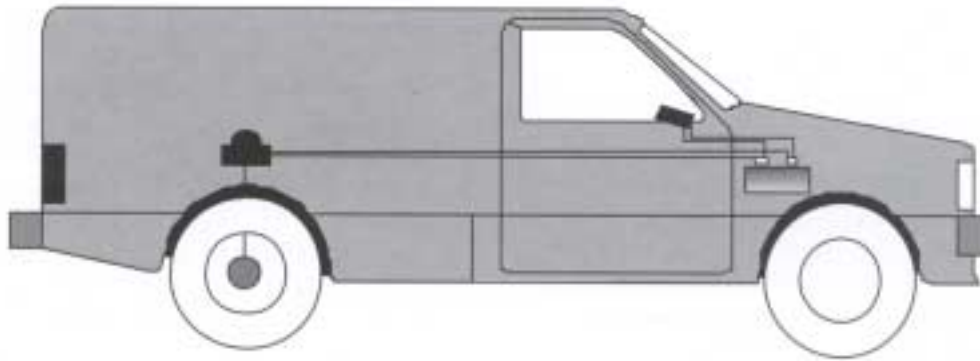

Figure B3 Diagrammatical representation of the TRL Integrator Unit fitted to a vehicle

Before each survey, the flexible metal cord from the cylindrical drum of the BI unit is passed through the hole in the floor and hooked onto the bracket on the rear axle. This cord must not touch the sides of the hole. Tension in the cord is maintained by a return spring inside the drum of the BI unit. The BI unit measures the unidirectional movement, in centimetres, between the vehicle chassis and the axle as the vehicle is driven along the road. This is displayed on a counter box, usually fixed to the front passenger fascia.

Survey procedure

- i A safe working environment should be maintained at all times. Many organisations will have on-site safety procedures which should be followed. As the vehicle may be moving slower than the majority of other traffic, it should be clearly signed and fitted with flashing lights.
- ii The vehicle should be well maintained and in good working order. The wheels should be properly balanced and the steering geometry correctly aligned. The tyres should not have flat spots or be unduly worn. Tyre pressures should be maintained precisely to the manufacturers specifications. The load in the vehicle must be constant. Ideally the vehicle should contain only the driver and observer, and no other load should be carried.
- iii The engine and suspension system should be fully warmed-up before measurements commence. This can be achieved by driving the vehicle for at least 5km before measurements start.
- iv The tension cord from the BI unit to the axle should only be connected during the survey. At all other times the cord should be disconnected to stop unnecessary wear to the BI unit. When attaching the cord to the rear axle, the cord should be pre-tensioned by turning the BI pulley 2.5 turns anti-clockwise. The wire is then wound around the pulley 2 turns in the same direction as the arrow. Note: the pulley must NOT be turned clockwise or suddenly released after being tensioned as the internal spring mechanism could be damaged.
- v When measurements are being taken the vehicle should normally be driven at constant speed, avoiding acceleration, deceleration and gear changes. This is necessary because the vehicle's response to a given profile varies with speed. To reduce reproducibility errors it is best to operate the RTRRMS at a standard speed of 80 km/h. However, if this speed is unsafe for reasons of traffic, pedestrians or restrictive road geometry, a lower speed of 50 or 32 km/h can be used. It is usual to use the same operating speed for all of the surveys. Calibration must be carried out at this operating speed.
- vi For general surveys, it is recommended that readings are recorded at half kilometre intervals. This distance should be measured with a precision odometer. The use of the vehicle odometer or kilometre posts is not recommended for survey purposes.
- vii There are two counters in the recording unit, connected by a changeover switch. This allows the observer to throw the switch at the end of each measurement interval so that the reading can be manually recorded while the other counter is working. The first counter can then be re-set to zero ready for the next changeover. Software is also available which automatically records the roughness data, vehicle speed and distances in spreadsheet form.
- viii The type of road surfacing should also be recorded to aid future analysis of the data. On completion of the survey, the wire cord should be disconnected from the rear axle.
- ix After the survey, the results should be converted into vehicle response roughness values (VR). The counts measured by the BI are in units of cumulative centimetres of uni-directional movement of the rear axle. These should be converted to vehicle response roughness values using the following equation.

$$VR = \frac{BI \text{ count} \times 10}{\text{section length (km)}}$$

Where VR = Vehicle Response (mnVkm)
BI = No of counts per section (cm)

- x These vehicle response roughness values should then be converted to units of estimated IRI, E[IRI], using a calibration that is unique to the RTRRMS at that time. The results of a typical survey in terms of E[IRI] are shown in Figure B4.

Calibration of a RTRRMS

The RTRRMS must be regularly calibrated against an instrument such as the TRL Profile Beam, the MERLIN or a rod and level survey. This calibration should preferably be carried out before the survey and checked on 'control' sites during the survey period to ensure that the RTRRMS remains within calibration. The calibration of the RTRRMS will need to be rechecked before any subsequent surveys or after any part of the suspension of the vehicle is replaced.

The calibration exercise basically involves comparing the results from the RTRRMS and the calibration instrument over several short road sections. The relationship obtained by this comparison can then be used to convert RTRRMS survey results into units of E[IRI]. The recommended practice for roughness calibration is described below.

- i A minimum of eight sections should be selected with varying roughness levels that span the range of roughness of the road network. The calibration sites should be on a similar type of road (ie paved or unpaved roads) to those being surveyed. The

sections should have a minimum length of 200m and should be of uniform roughness over their length. In practice it may be difficult to find long homogeneous sections on very rough roads. In this case it is better to include a shorter section than to omit high roughness sites from the calibration. The sections should be straight and flat, with adequate run-up and slow-down lengths and should have no hazards such as junctions so that the vehicle can travel in a straight course at constant speed along the whole section.

- ii The roughness of each section should be measured by the RTRRMS at the same vehicle speed that is to be used for the general survey. The value of VR (mm/km) should be the mean value of at least three test runs.
- iii The calibration instrument should measure roughness in both wheelpaths. The average of these IRI values (in m/km) is then plotted against the vehicle response for each of the test sections. The calibration equation for the RTRRMS is then derived by calculating the best fit line for the points. This relationship generally has a quadratic form but has also been found to be logarithmic depending upon the characteristics of the vehicles suspension and the levels of roughness over which the RTRRMS is being calibrated.

$$E[IRI] = a + b VR + c VR^2$$

Where E[IRI] = Estimated IRI (m/km)
VR = Vehicle Response (mm/km)
a, b and c = constants

The calibration equation can then be used to convert data from the RTRRMS into units of E[IRI].

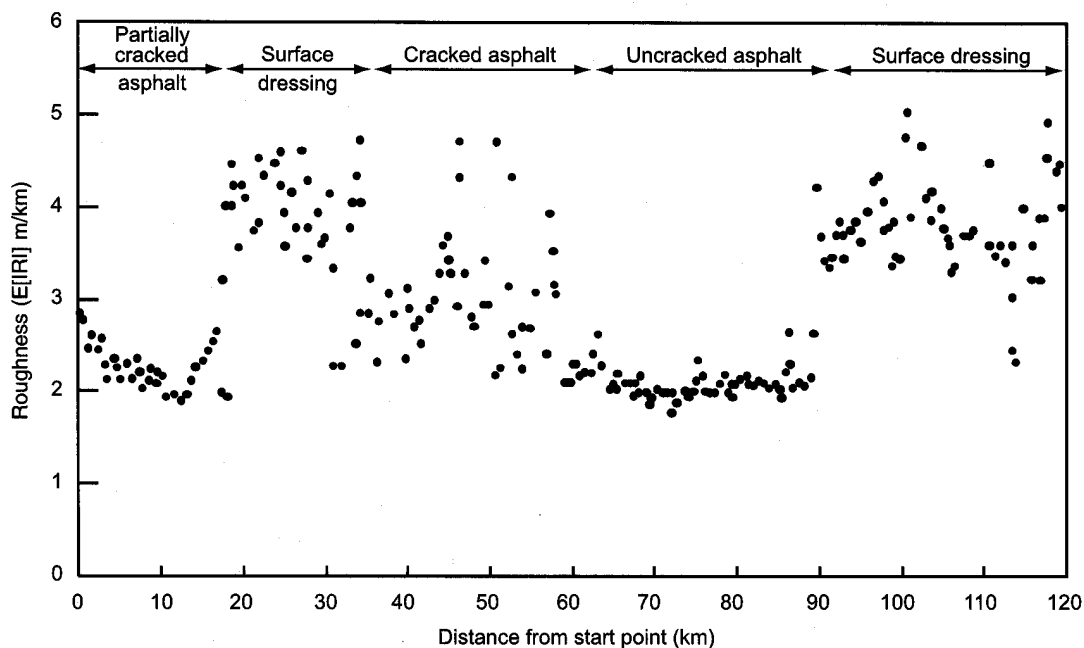

Figure B4 Road roughness profile

Appendix C: Deflection beam measurements

The simplest method of measuring the deflection of a road pavement is to use a loaded lorry and the deflection beam, originally devised by A C Benkelman. The beam consists of a slender pivoted beam, approximately 3.7m long, supported in a low frame which rests on the road. The frame is fitted with a dial gauge for registering the movement at one end of the pivoted beam, the other end of which rests on the surface of the road (Figure C1).

When making a deflection measurement, the tip of the beam is inserted between the dual rear-wheel assembly of the loaded truck. The dial gauge is set to zero and the truck then drives slowly forward. As the wheels approach the tip of the beam, the road surface deflects downwards and the movement is registered by the dial gauge. As the wheels move away from the tip of the beam, the road surface recovers and the dial gauge reading returns to approximately zero. The test procedure used by the TRL is described in detail by Smith and Jones (1980) and is summarised below.

Deflection test procedure

- i The lorry should have a capacity of at least 5 tonnes and should be fitted with twin rear wheels having a spacing of 40mm between the tyres. The lorry is loaded to give a rear axle load of 6350 kg (ie 3175 kg on each pair of twin rear wheels). The recommended tyre size is 8.25 x 20 and the tyres should be inflated to a pressure of 585 kN/m².
- ii Mark the point, in the vergeside wheelpath, at which the deflection is to be measured and position the lorry so that the rear wheels are 1.3m behind the marked point.
- iii Insert the deflection beam between the twin rear wheels until its measuring tip rests on the marked point. Insert a second beam between the offside wheels, if deflections are to be measured in both wheelpaths. It is helpful in positioning the lorry and aligning the beams if a pointer is fixed to the lorry 1.3m in front of each pair of rear wheels.
- iv Adjust the footscrews on the frame of the beam to ensure that the frame is level and that the pivoted arm is free to move. Adjust the dial gauge to zero and turn the buzzer on. Record the dial gauge reading which should be zero or some small positive or negative number.
- v The maximum and final reading of the dial gauge should be recorded while the lorry is driven slowly forward to a point at least 5m in front of the marked point. The buzzer should remain on until the final reading is taken. Care must be taken to ensure that a wheel does not touch the beam. If it does the test should be repeated.
- vi The transient deflection is the average of the loading and recovery deflections. At least two tests should be carried out at each chainage and the mean value is used to represent the transient test result. If the results of the two tests do not fall within the repeatability limits described in Table C 1 then a third test should be carried out.

Table C1 Repeatability of duplicate transient deflection tests

<i>Mean deflection (mm)</i>	<i>Max. permissible difference between the two tests (mm)</i>
<0.10	0.02
0.10 – 0.30	0.03
0.31 – 0.50	0.04
0.51 – 1.00	0.05
>1.00	0.06

Deflection readings can be affected by a number of factors which should be taken into account before the results can be interpreted. These are the temperature of the road, plastic flow of the surfacing between the loading wheels, seasonal effects and the size of the deflection bowl.

Road temperature

The stiffness of asphalt surfacings will change with temperature and therefore the magnitude of deflection can also change. The temperature of the bituminous surfacing is recorded when the deflection measurement is taken, thus allowing the value of deflection to be corrected to a standard temperature. It is recommended that 35°C, measured at a depth of 40mm in the surfacing, is a suitable standard temperature for roads in tropical climates.

The relation between temperature and deflection for a particular pavement is obtained by studying the change in deflection on a number of test points as the temperature rises from early morning to midday (Jones and Smith, 1980). It is not possible to produce general correction curves to cover all roads found in tropical countries so it is necessary to establish the deflection/temperature relationship for each project. Fortunately, it is often found that little or no correction is required when the road surfacing is either old and age hardened or relatively thin.

Plastic flow

Plastic flow of new bituminous surfacings can occur during deflection testing. As the surfacing is squeezed up between the twin wheels the transient

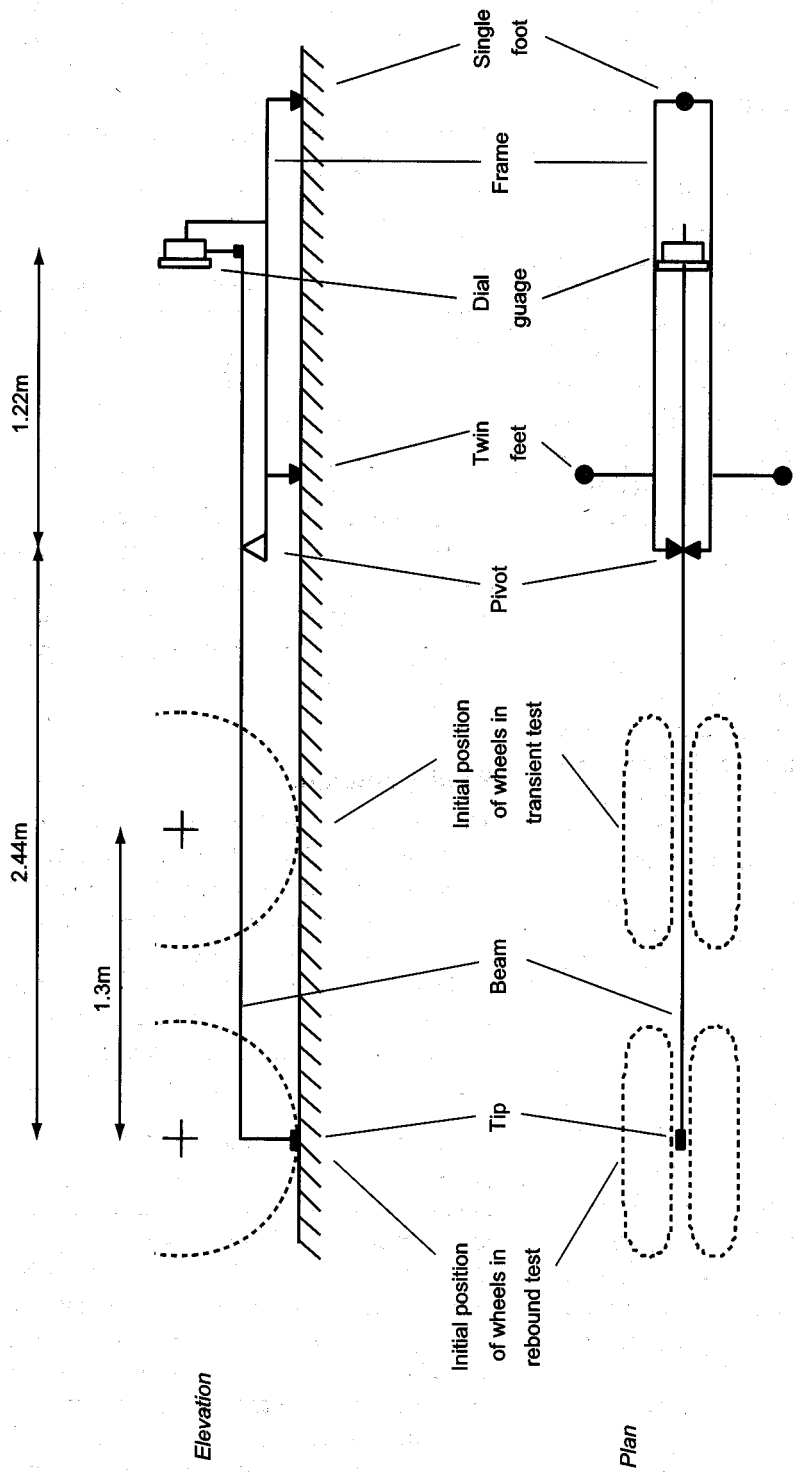

Figure C1 Diagrammatic representation of the deflection beam

deflection obtained will be less than the true value. Plastic flow can easily be identified by high negative final readings being recorded during the transient test. Alternative test procedures such as the 'rebound' deflection test (Smith and Jones, 1980) do not identify when plastic flow is occurring.

Seasonal effects

In areas where the moisture content of the subgrade changes seasonally, the deflection will also change. For overlay design purposes, it is usual to use values which are representative of the most adverse seasonal conditions. It is therefore normal practice to carry out surveys just after the rainy season. If this cannot be done, an attempt should be made to correct for the seasonal effect. However, this requires a considerable data bank of deflection results and rainfall records before reliable corrections can be made.

Size of deflection bowl

The size of the deflection bowl can occasionally be so large that the front feet of the deflection beam lie within the bowl at the beginning of the deflection test. If this happens, the loading and recovery deflection will differ. The simplest way to check whether the differences in loading and recovery deflection are caused by the size of the bowl is to place the tip of another beam close to the front feet of the measurement beam at the beginning of the transient test. This second beam can be used to measure any subsequent movement of the feet of the first beam as the lorry moves forward. If feet movements larger than 0.06mm are observed only the recovery part of the deflection cycle should be used for estimating the value of transient deflection.

Appendix D: Deflection beam survey procedure

A safe working environment should be maintained at all times. Many organisations will have on-site safety procedures which should be followed. Where there are no local safety procedures those described in Overseas Road Note 2 are recommended (TRRL, 1985).

Deflection beam measurements are made in both wheelpaths of the slow lane on dual carriageways and in both lanes of a two-lane road. The following strategy is adopted.

- i Tests are carried out on a basic pattern of 50 or 100 metre spacings.
- ii Additional tests should be undertaken on any areas showing atypical surface distress.
- iii When a deflection value indicates the need for a significantly thicker overlay than is required for the adjacent section, the length of road involved should be determined by additional tests.

After all measurements have been made, they should be corrected for any temperature effect (Appendix C). It is then convenient to plot the deflection profile of the road for each lane, using the larger deflection of either wheelpath at each chainage. Any areas showing exceptionally high deflections which may need reconstruction or special treatment can then be identified.

The deflection profile is then used to divide the road into homogeneous sections, in such a way as to minimise variation in deflections within each section. The minimum length of these sections should be compatible with the frequency of thickness adjustments which can sensibly be made by the paving machine, whilst still maintaining satisfactory finished levels. When selecting the sections the topography, subgrade type, pavement construction and maintenance history should all be considered.

There are a number of statistical techniques that can be used to divide deflection data into homogeneous sections. One of these techniques is the cumulative sum method, where plots of the cumulative sums of deviations from the mean deflection against chainage can be used to discern the sections. The cumulative sum is calculated in the following way.

$$S_i = x_i - x_m + S_{i-1}$$

where x_i = Deflection at chainage
 x_m = Mean deflection
 S_i = Cumulative sum of the deviations
from the mean deflection at chainage i

Using the cumulative sums, the extent to which the measured deflections on sections of road varies from the mean deflection of the whole road can be determined. Changes in the slope of the line connecting the cumulative sums will indicate inhomogeneity.

The coefficient of variation (CoV = standard deviation/mean) may be used to determine the level of homogeneity using the following guidelines.

CoV < 0.2	good homogeneity
0.2 < CoV < 0.3	moderate homogeneity
CoV > 0.3	poor homogeneity

CoVs greater than 0.3 usually indicate a highly skewed distribution produced, for example, by a number of relatively 'stronger' points within a weaker section. Other authorities (NITRR, 1983) (AUSTROADS, 1992) have recommended, as a guide, that a homogeneous section is one where the deflection values have a CoV of 0.25 or less.

The final stage of the procedure is to calculate the representative deflection for each homogeneous section of the road. The proposed method will tend to separate out areas of very high deflections on areas that warrant special treatment or reconstruction and therefore the distribution of the remaining deflection measurements will approximate to a normal distribution. The representative deflection, which is the 90th percentile value, can then be calculated as follows:

$$\text{Representative deflection} = x_m + 1.3 \text{ standard deviation}$$

Appendix E: Falling Weight Deflectometer (FWD) test procedure

Calibration

Evidence of a satisfactory absolute calibration of the deflection sensors and the load cell shall be provided by the operator of the FWD. The absolute calibration should be carried out annually, or as soon as possible after any sensor has been replaced. The calibration should be carried out by either the manufacturer or a recognised testing authority accredited by the manufacturer.

In addition to the annual absolute calibration other checks need to be carried out every 6 weeks. These are the consistency check and the relative consistency check.

The consistency check is used to verify whether the central deflection sensor and the load cell are giving reproducible results over a period of time. In this check five test points, in three road sections, are tested at regular 6 week intervals. The road sections selected should be representative of the pavement structures that are generally being tested, be in good condition, be lightly trafficked and be efficiently drained such that any seasonal variation in deflection is minimised. If the sections have significant layers of bituminous material then the temperature of surfacing should be recorded during the tests. Examination of the variation in deflection, normalised to a standard load and temperature, will provide an indication of any inconsistency in the equipment.

The relative consistency check is used to ensure that all the deflection sensors on the FWD are in calibration with respect to each other. The relative consistency check uses a calibration tower, supplied by the manufacture, in which all the sensors are stacked vertically. The sensors are then all subject to the same pavement deflection. The procedure is fully described in the manufacturers literature or can be found in SHRP-P-652 (1993b).

Test procedure

A safe working environment should be maintained at all times. Many organisations will have on-site safety procedures which should be followed. The safety aspects of a FWD survey are particularly difficult to manage, as it is a mobile operation, and the supervising engineer should ensure that satisfactory procedures are followed. Where short lengths of road are being investigated they should be coned off. If measurements are being carried out over longer lengths of road then the operator, driver and traffic control personnel should always be extremely aware of both the movements of the testing equipment and other vehicles on the road. In addition to static road signs, the towing vehicle should always be fitted with

flashing lights and direction signs and all personnel should wear high visibility safety jackets.

Typically tests should be carried out at intervals of 20-100 metres in the vergeside wheelpath in each direction. Additional tests should be undertaken on any areas showing atypical surface distress.

On flexible pavements the load level should be set at a nominal load of 50kN +/- 10%. On roads with bituminous seals, often found in the developing world, this level of load may possibly over-stress the pavement, in which case the load level should be reduced. The load should be applied through a 300mm diameter plate and the load pulse rise time should lie between 5 and 15 milliseconds.

The deflection should be measured by at least five and preferably seven deflection sensors having a resolution of one micron. The location of the sensors depends on the stiffness of the pavement structure. The stiffness of the subgrade has a major influence on the shape of the deflection bowl and therefore there should be at least two sensors at such a distance from the load centre as to enable the stiffness of the subgrade to be assessed. In the case where seven sensors are available, the recommended sensor positions are given in Table E1.

Table E1 Recommended sensor positions

Flexible pavement	Distance from centre of load (mm)						
	1	2	3	4	5	6	7
Thick asphalt surfacing	0	300	600	900	1200 ¹	1500	2100
Thin asphalt surfacing or seal	0	200 ¹	300	600	900	1500	1800

¹ Where only 6 sensors are available these positions will be omitted.

Temperature measurements

When the road has an asphalt surfacing the deflection may change as the temperature of the surfacing changes. Also when the deflection bowl is to be used to estimate pavement layer moduli, the stiffness of the asphalt surfacing will need to be corrected to a standard temperature. It is therefore necessary to measure the temperature of the surfacing during testing. In temperate climates measurements taken hourly may be sufficient, however, in tropical climates the pavement temperature will rise quickly during mid-morning and can reach a temperature at which the asphalt surfacing is liable to plastic deformation during testing. This must be carefully monitored and temperature measurements at this critical time of the day may need to be taken every 15 or 20 minutes.

The temperature of the pavement can be measured using either a short-bulb mercury thermometer or a digital thermometer. The temperature holes should be at least 0.3m from the edge of the surfacing and, where possible, they should be pre-drilled to allow the heat to dissipate before temperatures are measured. The temperature of the surfacing should not be measured under any road markings. Glycerol or oil in the bottom of the hole will ensure a good thermal contact between the temperature probe or thermometer and the bound material.

Where the asphalt surfacing is less than 150mm the temperature should be measured at a depth of 40mm. When the surfacing exceeds 150mm, it is recommended that temperatures should be recorded at two depths, 40 and 100mm.

Appendix F: TRL Dynamic Cone Penetrometer (DCP) test procedure

The TRL DCP uses an 8 kg hammer dropping through a height of 575mm and a 60° cone having a maximum diameter of 20mm.

The instrument is assembled as shown in Figure F1. It is supplied with two spanners and a tommy bar to ensure that the screwed joints are kept tight at all times. To assist in this the following joints should be secured with a non-hardening thread locking compound prior to use:

- Handle/hammer shaft
- Coupling/hammer shaft
- Standard shaft/cone

The instrument is usually split at the joint between the standard shaft and the coupling for carriage and storage and therefore it is not usual to use locking compound at this joint. However it is important that this joint is checked regularly during use to ensure that it does not become loose. Operating the DCP with any loose joints will significantly reduce the life of the instrument.

Operation

A safe working environment should be maintained at all times. Many organisations will have on-site safety procedures which should be followed. Where there are no local safety procedures those in Overseas Road Note 2 are recommended (TRRL, 1985).

After assembly, the first task is to record the zero reading of the instrument. This is done by standing the DCP on a hard surface, such as concrete, checking that it is vertical and then entering the zero reading in the appropriate place on the proforma (See Figure F2).

The DCP needs three operators, one to hold the instrument, one to raise and drop the weight and a technician to record the readings. The instrument is held vertical and the weight raised to the handle. Care should be taken to ensure that the weight is touching the handle, but not lifting the instrument, before it is allowed to drop. The operator must let it fall freely and not partially lower it with his hands.

It is recommended that a reading should be taken at increments of penetration of about 10mm. However it is usually easier to take a reading after a set number of blows. It is therefore necessary to change the number of blows between readings, according to the strength of the layer being penetrated. For good quality granular bases readings every 5 or 10 blows are usually satisfactory but for weaker sub-base layers and subgrades readings every 1 or 2 blows may be appropriate. There is no disadvantage in taking too many readings, but if readings are taken too infrequently, weak spots may be missed and it

will be more difficult to identify layer boundaries accurately, hence important information will be lost.

When the extended version of the DCP is used the instrument is driven into the pavement to a depth of 400-500mm before the extension shaft can be added. To do this the metre rule is detached from its baseplate and the shaft is split to accept the extension shaft. After re-assembly a penetration reading is taken before the test is continued.

After completing the test the DCP is removed by tapping the weight upwards against the handle. Care should be taken when doing this; if it is done too vigorously the life of the instrument will be reduced.

The DCP can be driven through surface dressings but it is recommended that thick bituminous surfacings are cored prior to testing the lower layers. Little difficulty is normally experienced with the penetration of most types of granular or lightly stabilised materials. It is more difficult to penetrate strongly stabilised layers, granular materials with large particles and very dense, high quality crushed stone. The TRL instrument has been designed for strong materials and therefore the operator should persevere with the test. Penetration rates as low as 0.5mm/blow are acceptable but if there is no measurable penetration after 20 consecutive blows it can be assumed that the DCP will not penetrate the material. Under these circumstances a hole can be drilled through the layer using an electric or pneumatic drill, or by coring. The lower pavement layers can then be tested in the normal way. If only occasional difficulties are experienced in penetrating granular materials, it is worthwhile repeating any failed tests a short distance away from the original test point.

If, during the test, the DCP leans away from the vertical no attempt should be made to correct it because contact between the shaft and the sides of the hole can give rise to erroneous results. Research (Livneh, 1995) has shown that there can be an overestimate of subgrade strength as a result of friction on the rod caused by either tilted penetration through, or collapse of, any upper granular pavement layers. Where there is a substantial thickness of granular material, and when estimates of the actual subgrade strength are required (rather than relative values) it is recommended that a hole is drilled through the granular layer prior to testing the lower layers.

If the DCP is used extensively for hard materials, wear on the cone itself will be accelerated. The cone is a replaceable part and it is recommended by other authorities that it should be replaced when its diameter is reduced by 10 per cent. However, other causes of wear can also occur hence the cone should be inspected before every test.

Interpretation of results

The results of the DCP test are usually recorded on a field data sheet similar to that shown in Figure F2. The results can then either be plotted by hand, as shown in Figure F3, or processed by computer (TRRL, 1990).

Relationships between DCP readings and CBR have been obtained by several research authorities (see Figure F4). Agreement is generally good over most of the range but differences are apparent at low values of CBR in fine grained materials. It is expected that for such materials the relationship between DCP and CBR will depend on material state and therefore, if more precise values are needed it is advisable to calibrate the DCP for the material being evaluated.

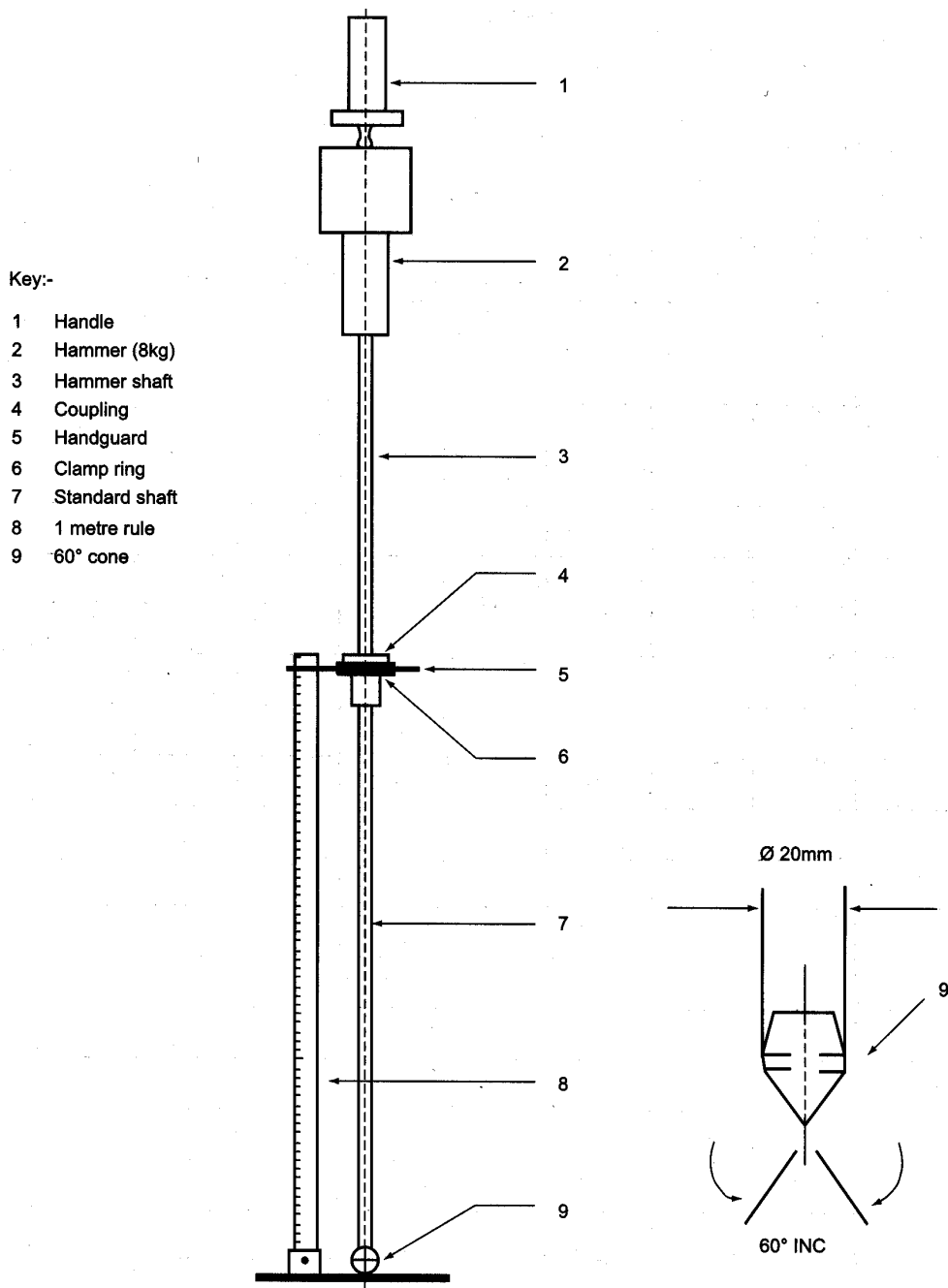

Figure F1 TRL Dynamic Cone Penetrometer

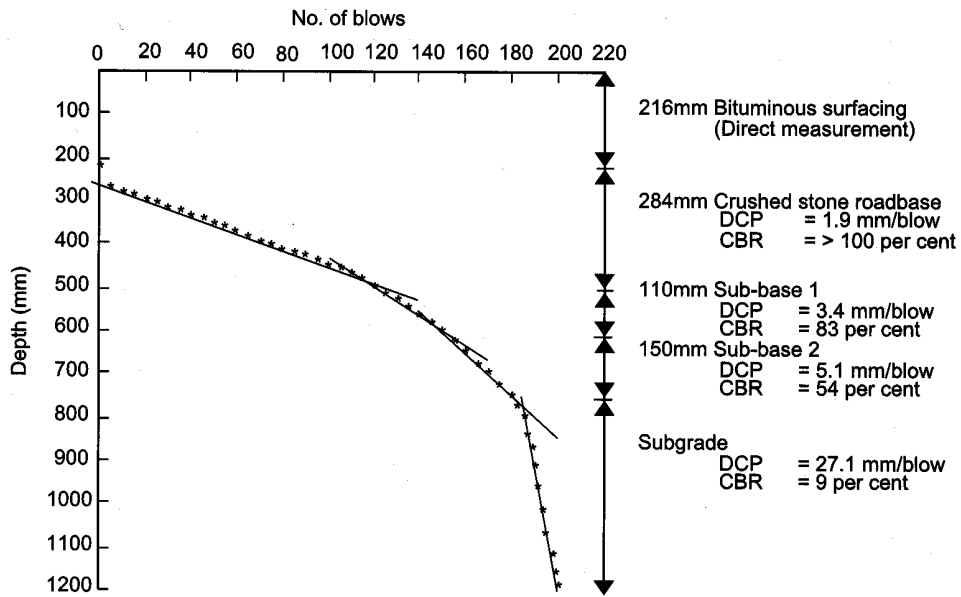
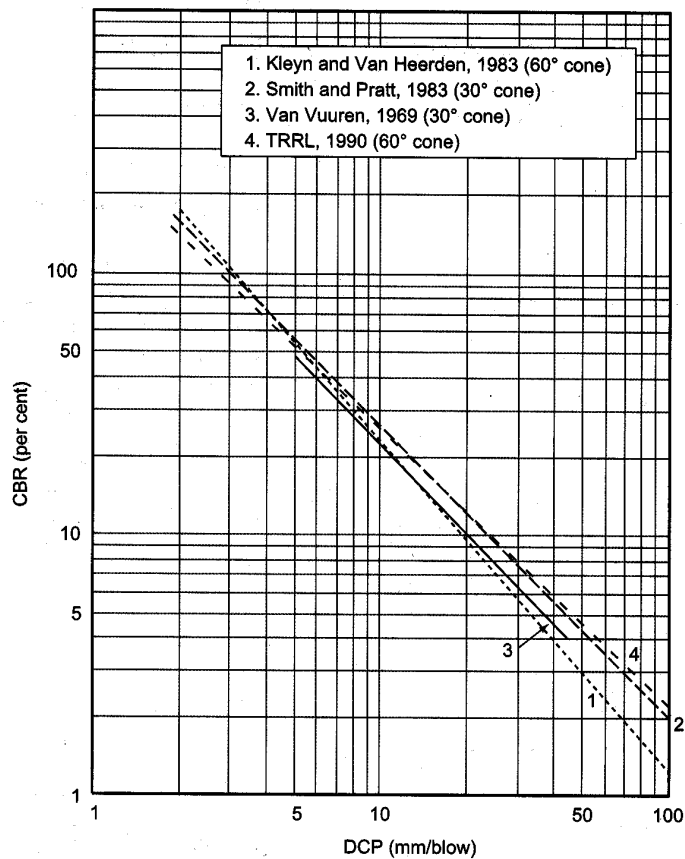

Figure F3 Typical DCP test result



1. $\text{Log}_{10}(\text{CBR}) = 2.632 - 1.28 \text{Log}_{10}(\text{mm/blow})$
2. $\text{Log}_{10}(\text{CBR}) = 2.555 - 1.145 \text{Log}_{10}(\text{mm/blow})$
3. $\text{Log}_{10}(\text{CBR}) = 2.503 - 1.15 \text{Log}_{10}(\text{mm/blow})$
4. $\text{Log}_{10}(\text{CBR}) = 2.48 - 1.057 \text{Log}_{10}(\text{mm/blow})$

Figure F4 DCP-CBR relationships

Appendix G: Test pit procedure

Purpose

The purpose of carrying out a test pit investigation is to confirm the engineers understanding of the information from surface condition, deflection and DCP surveys. It is a time consuming and expensive operation, and for this reason the location of each test pit should be carefully selected to maximise the benefit of any data collected. The condition of the road pavement and the primary purpose for the pit investigation should be recorded on the Test Pit Log (see Figure G1).

Labour, equipment and materials

Test pits can be excavated either by machine or manually. The choice will normally be determined by the availability of plant and the test pit programme, as machine operations are usually more productive but more costly than manual methods.

The following personnel are required:

- traffic controllers - a minimum of one at each end of the site;
- 2 (if machine excavation) or 3 (if manual excavation) labourers;
- 1 machine operator if applicable;
- 1 driver for vehicle; and
- 1 supervising technician.

Equipment and materials requirements are as follows:

- 1 backhoe (for machine excavation);
- 1 jack hammer with generator (to assist with manual excavation);
- 1 pick;
- 1 or 2 spades (a fence post hole digger can also be useful);
- 1 tamper or plate compactor for backfilling test pit;
- material to backfill and seal test pit : gravel, cement for stabilising gravel, water and cold mix for resurfacing;
- 1 broom to tidy area on completion;
- 1 chisel is often useful to assist with inspecting the wall of the test pit;
- equipment necessary to complete any required onsite testing;
- 1 tape measure and thin steel bar to span pit (to assist with depth measurements);
- sample bags and containers, with some means of labelling each;
- test pit log forms and clipboard; and
- sample log book.

Sampling and testing

Before commencing the survey in the field, the engineer should be clear as to the information required from each test pit. This will depend on the results of previous surveys, the materials specifications in use and an understanding of the pavement behaviour. Some field testing might be necessary as well as subsequent laboratory testing of samples extracted from the pit. Table G1 summarises the various tests that may be required and references the relevant standards with which the tests should comply. Not all these tests will be necessary and the engineer must decide on those which are required.

Procedure

A safe working environment should be maintained at all times. Many organisations will have on-site safety procedures which should be followed. Where there are no local safety procedures those described in Overseas Road Note 2 are recommended (TRRL, 1985).

Once it has been decided what testing is to be carried out and the location of the trial pits has been confirmed, the following procedure should be adopted.

- i Set up traffic control.
- ii Accurately locate position of test pit and record this on the Pavement Test Pit Log (see Figure G1). Usually, the position of a pit will be apparent after completion due to the patched surface. However, if long term monitoring is required, a permanent location marker should be placed at the roadside. Record any relevant details such as surrounding drainage features, road condition and weather.
- iii Define the edge of the test pit and remove surfacing. The required size of pit will depend on the sample sizes necessary for the selected tests, but it can be increased later if found to be too small. Usually an area of about 0.8m by 0.8m will be sufficient for manual excavation, and the minimum working area required for a backhoe operation will be sufficient for machine excavations. The edge of the pit can be cut with a jack hammer or pick and the surfacing 'peeled' off, taking care not to disturb the surface of the roadbase. The average thickness of surfacing should be recorded.
- iv If density tests are to be performed, a smooth, clean and even surface is required. It is important for the accuracy of the test that the layer is homogeneous. For the sand replacement method, no prior knowledge is required of the layer thickness since this becomes obvious as the hole is excavated. If a nuclear density meter is used,

the thickness of the layer can be estimated from the DCP results to determine the depth of testing.

- v On completion of any required density testing, the layer can be removed over the extent of the trial pit, a visual assessment made of the material and samples taken for laboratory testing. Care should be taken not to disturb the adjacent lower layer. The thickness of the layer and the depth at which samples are taken should be measured. All information should be recorded on the Pavement Test Pit Log.
- vi Continue to sample, test and excavate each pavement layer following the procedure above. Once it has been decided that there is no need to excavate further, the total depth of pit should be recorded along with any other information such as appearance of water in any of the layers.
- vii All samples should be clearly labelled and proposed tests for the pit materials should be logged in a sample log book to avoid later confusion in the laboratory.
- viii The pit should be backfilled in layers with suitable material which should be properly compacted. It is often good practice to stabilise the upper layer with cement accepting that full compaction will not be achieved. A bituminous cold mix can be used to patch the backfilled pit.
- ix The site should be cleared and left in a tidy and safe condition for traffic.

TEST PIT LOG

Location Data	Date:	Done by:	Weather:		
Road Number:	From:	To:	Section:		
Chainage:	Position:	Pit Number:			
Pavement Condition:					
Purpose of Investigation:					
Test Pit Data		Method of Pitting:			
Depth (mm)	Layer Function	Material Description	Sample Depth (mm)	Tests Required	Remarks
<div style="display: flex; flex-direction: column; align-items: center;"> <div style="margin-bottom: 20px;">500</div> <div style="margin-bottom: 20px;">1000</div> <div>1500</div> </div>					
Notes for Completing Test Pit Data					
Layer Function:	S-Surfacing, R-Roadbase, SB-Sub-base, SF-Select Fill, SGR-Subgrade				
Material Description:	Subjective assessment of material type and properties				
Sample Depth:	Depth (range) at which any samples taken				
Tests Required:	Note any laboratory tests required				
Remarks:	Note any particular points of interest such as pavement or drainage condition, on site tests (moisture, density), evidence of groundwater etc.				

Figure G1 Test Pit Log sheet

Table G1 Possible information from test pit investigation

<i>Property</i>	<i>Possible tests¹</i>	<i>Field or Lab²</i>	<i>Procedure³</i>	<i>Remarks</i>
Particle size distribution	Sieve analysis	Lab	BS1377:Part 2:1990	Initial visual assessment on site.
Plasticity	Plastic and liquid limits, Plasticity index	Lab	BS1377:Part 2:1990	Initial visual assessment on site.
	Linear shrinkage	Lab	BS1377:Part 2:1990	Correlated to PI
Particle shape ⁴	Elongation index	Lab	BS812:Part 105:1990	
	Flakiness index	Lab	BS812:Part 105:1990	
Particle strength ⁴	Aggregate crushing value	Lab	BS812:Part 110:1990	Los Angeles Abrasion Value given in ASTM C 131-96 and C 535-96
	10% fines value	Lab	BS812:Part 111:1990	
	Aggregate impact value	Lab	BS812:Part 112:1990	
Particle durability ⁴	Aggregate abrasion	Lab	BS812:Part 113:1990	Los Angeles Abrasion Value given in ASTM C 131-96 and C 535-96
	Accelerated polishing	Lab	ASTM D 3319-90	
Particle soundness	Sulphate test	Lab	BS812:Part 121:1989	
Particle density	Particle density	Lab	BS1377:Part 2:1990	For soils
	Particle density	Lab	BS812:Part 2:1975	For aggregates
Moisture content	Oven dry ⁷	Lab	BS1377:Part 2:1990	Recommended method
	'Speedy'	Field	Suppliers instructions	
	Nuclear density meter	Field	Suppliers instructions	Hazardous radioactive material
Moisture density relationship	Tests at various levels of compaction	Lab	BS1377:Part 4:1990	
Layer ⁵ density	Sand replacement method	Field	BS1377:Part 9:1990	
	Core cutter method	Lab	BS1377:Part 9:1990	
	Nuclear density meter	Field	Suppliers instructions	Hazardous radioactive material
Bearing capacity	DCP	Field	See Appendix F	
	California bearing ratio	Lab or Field	BS1377:Part 4:1990	
Shear strength ⁶	Vane test	Field	BS1377:Part 9:1990	
	Various load tests	Lab	BS1377:Part 8/9:1990	

1 In some cases, the possible tests listed for a given property are alternatives. In other cases all the tests listed for a given property might be required. The engineer must decide for which properties information is required and then design a suitable testing programme.

2 Field tests require testing at the site and possibly further analysis in the laboratory. Laboratory tests require only sampling in the field. All sampling should be carried out in accordance with the general guidance of BS1377 or BS812, whichever is applicable, as well as any specific requirements for each test.

3 British Standards (BS) are quoted where applicable. Where no British Standard is available, an alternative is quoted.

4 These tests will only be required for surfacing or base materials.

5 The layer must consist of homogeneous material for these tests.

6 These tests will only be required where a slope stability or settlement problem is being evaluated and will only apply to subgrade materials.

7 The oven drying method is recommended since it provides a fundamental measure of the moisture content. Both the 'Speedy' and the Nuclear Density Meter methods require accurate calibration and validation, since they derive the moisture content by indirect analysis, but they have the advantage of providing instant results. Validation should always be made with reference to the oven dry method.

Appendix H: Sand patch test

The sand patch test is described in detail in BS 598 Part 105 (1990). The method is summarised below.

Apparatus

- i Measuring cylinder of 50ml volume.
- ii A spreader disc comprising a flat wooden disc 65mm in diameter with a hard rubber disc 1.5mm thick, stuck to one face. The reverse face being provided with a handle.
- iii Washed and dried sand, with rounded particle shape, complying with the grading given in Table H 1.

Table H1 Grading of sand

<i>BS test sieve (mm)</i>	<i>% by mass passing</i>
0.600	100
0.300	90 – 100
0.150	0 – 15

Procedure

- i Dry the surface to be measured and, if necessary, sweep clean with a brush.
- ii Fill the cylinder with sand and, taking care not to compact it by unnecessary compaction, strike off the sand level with the top of the cylinder.
- iii Pour the sand into a heap on the surface to be tested, and spread the sand over the surface, working the disc with its face kept flat, in a rotary motion so that the sand is spread into a circular patch. The patch should be of the largest diameter which results in the surface depressions just being filled with sand to a level of the peaks.
- iv Measure the diameter of the sand patch to the nearest 1 nun at four diameters every 45° and calculate the mean diameter (D) to the nearest 1mm.
- v Calculate the texture depth to the nearest 0.01 nun from the following equation.

$$\text{Texture depth (mm)} = 63660 / D^2$$

Note: For surfacings having a texture depth of less than 1 mm the volume of sand will have to be reduced to 25ml or less. The texture depth is then calculated using the following equation:

$$\text{Texture depth (mm)} = \frac{\text{Volume of sand (ml)} \cdot 1000}{\text{Area of patch (mm}^2\text{)}}$$

Appendix I: The portable skid-resistance tester

The portable skid-resistance tester, shown in Figure 11, was developed by the Road Research Laboratory and is described in detail in Road Note 27 (RRL, 1969). The testing procedure is summarised below.

Setting the tester

- i Set the base level using the in-built spirit level and the three levelling screws on the base-frame.
- ii Raise the head so that the pendulum arm swings clear of the surface. Movement of the head of the tester, which carries the swinging arm, graduated scale, pointer and release mechanism is controlled by a rack and pinion on the rear of the vertical column. After unclamping the locking knob A at the rear of the column, the head may be raised or lowered by turning either of the knobs B/B¹. When the required height is obtained, the head unit must be locked in position by using the clamping knob A.
- iii Check the zero reading. This is done by first raising the swinging arm to the horizontal release position, on the right-hand side of the tester. In this position it is automatically locked in the release catch. The pointer is then brought round to its stop in line with the pendulum arm. The pendulum arm is released by pressing button C. The pointer is carried with the pendulum arm on the forward swing only. Catch the pendulum on its return swing, and note the pointer reading. Correct the zero setting as necessary by adjusting the friction rings.
- iv With the pendulum arm free, and hanging vertically, place the spacer, which is attached to the base of the vertical column, under the lifting-handle setting-screw to raise the slider. Lower the head of the tester, using knob B, until the slider just touches the road surface, and clamp in position with knob A. Remove the spacer.
- v Check the sliding length of the rubber slider over the surface under test, *by gently lowering the pendulum arm* until the slider just touches the surface first one side and then the other side of the vertical. The sliding length is the distance between the two extremities where the sliding edge of the rubber touches the test surface. To prevent undue wear of the slider when moving the pendulum arm through the arc of contact, the slider should be raised off the road surface by means of the lifting handle. If necessary, adjust to the correct length by raising or lowering the head slightly. When the apparatus is set correctly the sliding length should be between 125 and 127mm as indicated by the measure provided. Place the pendulum arm in its locked position. The apparatus is now ready for testing.

Operation of the tester

- i After ensuring that the road surface is free from loose grit, wet both the surface of the road and the slider.
- ii Bring the pointer round to its stop. Release the pendulum arm by pressing button C *and catch it off the return swing, before the slider strikes the road surface*. Record the indicated value.
- iii Return the arm and pointer to the locked position, keeping the slider clear of the road surface by means of the lifting handle. Repeat the process, spreading water over the contact area with a hand or brush between each swing. Record the mean of five successive swings, provided they do not differ by more than three units. If the range is greater than this, repeat swings until three successive readings are constant; record this value.
- iv Raise the head of the tester so that it swings clear of the surface again and check the free swing for any zero error.
- v Sliders should be renewed when the sliding edge becomes burred or rounded. One slider edge can usually be used for at least 100 tests (500 swings). New sliders should be roughened before use by swinging several times over a dry piece of road.

Temperature correction

The effect of temperature on rubber resilience makes it necessary to correct the measured value of skid resistance to a standard temperature. The road temperature is measured by recording the temperature of the water after the test using a digital thermometer and surface probe. It is recommended that in tropical climates the value should be corrected to a standard temperature of 35°C using the following relation (Beaven and Tubey, 1978).

$$SRV_{35} = (100 + t)/135.SRV_t$$

Where SRV_{35} = Skid resistance value at 35°C
 SRV_t = Measured skid resistance value
 t = Temperature of test (°C)

At this standard temperature the corrected values will be 3-5 units lower than comparable surfaces in the UK, where results are corrected to 20°C.

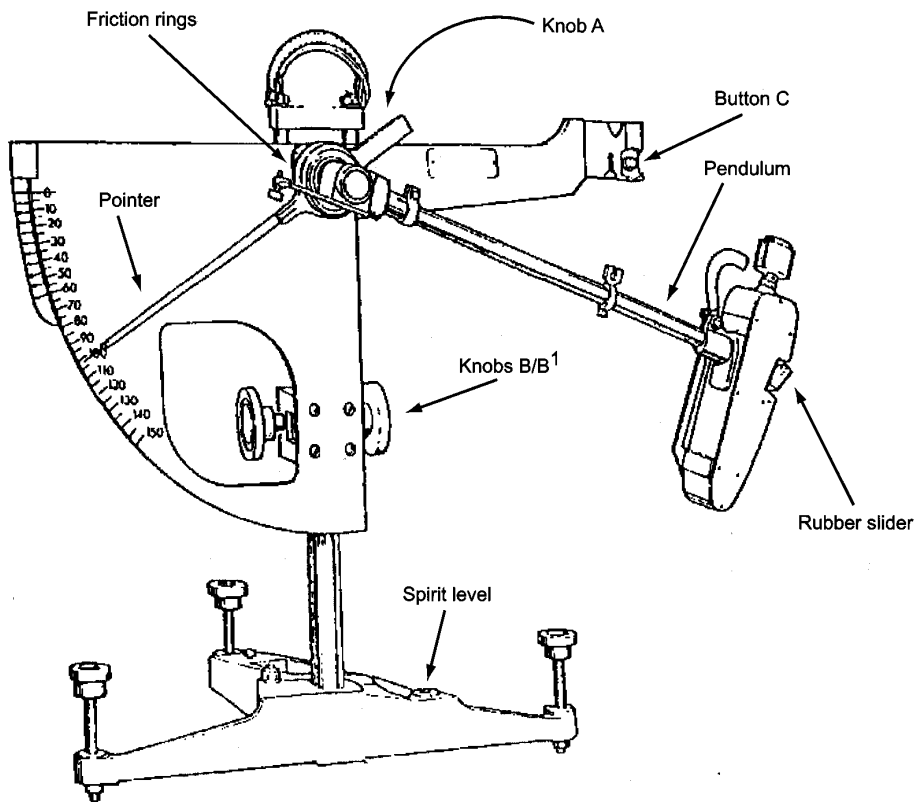

Figure 11 Portable skid-resistance tester

ISSN 0951-8797

OS-E

**A guide to the pavement evaluation and
maintenance of bitumen-surfaced roads
in tropical and sub-tropical countries**

ORN 18